

119GJ05EN

AUTOMATIC BARRIERS

Official Partner



MILANO 2015

FEEDING THE PLANET
ENERGY FOR LIFE



Installation manual

G2080EZ



English

EN



WARNING!
important safety instructions for people:
READ CAREFULLY!



Premise

- Employ this product only for the use for which it was expressly made. Any other use is dangerous. CAME S.p.A is not liable for any damage caused by improper, wrongful and unreasonable use
- The safety of this product and its proper fitting depends, therefore, on respecting its technical characteristics and proper fitting, to be done in state-of-the-art fashion, and under safe conditions as expressly explained in the literature that comes with the product.
- Keep these warnings together with the installation and operation manuals that come with the operator.

Before installing

(checking what's there: if something is missing, do not continue until you have complied with all safety provisions)

- Fitting and testing must be only performed by qualified technicians
- Laying the cables, installation and testing must follow state-of-the-art procedures as dictated by regulations
- Before beginning any operation it is mandatory to carefully read all instructions; improper installation may result in serious harm to people and things
- Make sure the boom is in good mechanical state, balanced and aligned, and that it opens and closes properly. Also, if needed, fit suitable protections or use proper safety sensors
- If the operator is to be installed at a height of over 2.5 m from the ground or other access level, make sure you have any necessary protections and/or warnings in place
- If any pedestrian openings are fitted into the operator, there must also be a system to block their opening while they are moving
- Make sure that the opening automatic barrier cannot entrap people against the fixed parts of the operator
- Do not install the operator upside down or onto elements that could yield and bend. If necessary, add suitable reinforcements to the anchoring points
- Do not install on tilted surfaces
- Make sure the temperature range shown on the product literature is suitable to the climate where it will be installed as explained in the manual.

Installing

- Suitably section off and demarcate the entire installation site to prevent unauthorized persons from entering the area, especially minors and children
- Be careful when handling operators that weigh over 20 kg. If need be, use proper safety hoisting equipment
- The CE-marked safety devices (photocells, stepping plates, sensitive safety-edges, emergency buttons, and so on), must be fitted in compliance with the regulations in effect and according to state-of-the-art criteria, taking into account the environment, the type of required service and of the working forces applied to moving leaves. Any shearing or conveying points must be sensor-protected
- Any residual risks must be pointed out to end users and highlighted with pictograms as provided by the law.
- All opening commands (that is, buttons, key switches, magnetic readers, and so on) must be installed at least 1.85 m from the perimeter of the barrier's working area, or where they cannot be reached from outside the barrier. Also, any direct commands (buttons, touch panels, and so on) must be installed at least 1.5 m from the ground and must not be reachable by unauthorized persons
- The automatic barrier must clearly show its identification data.
- Before connecting the main power supply make sure that the identification data correspond to the those of the network
- The automatic barrier must be connected to an effective regulation grounding system.
- The manufacturer declines any liability for using non-original products; which would result in warranty loss
- All maintained action commands, must be fitted in places from which the moving barrier and transit and driving areas are visible
- Apply, if missing, a permanent sign showing the position of the release device
- Before delivering to the users, make sure the system is EN 12453 and EN 12445 standard compliant (regarding impact forces), and also make sure the system has been properly adjusted and that any safety, protection and manual release devices are working properly
- Apply Warning Signs where necessary and in a visible place (such as the gate's license plate)

Special user-instructions and recommendations

- Keep barrier operation areas clean and free of any obstructions. Make sure the photocell's operating field is clear of any obstructions
- Do not allow children to play with fixed commands, or to loiter in the barrier's maneuvering area. Keep any remote control transmitters or any other command device away from children, to prevent the operator from being accidentally activated
- The apparatus may be used by children of eight years and above and by physically, mentally and perceptively challenged people, or even ones without any experience, provided this happens under close supervision or once they have been properly instructed to use the apparatus safely and to the potential hazards involved
- Children must not play with the apparatus. Cleaning and maintenance by users must not be done by children, unless properly supervised
- Frequently check the system for any malfunctions or

signs of wear and tear or damage to the moving structures, to the component parts, all anchoring points, including cables and any accessible connections

- Frequently check the system for any malfunctions or signs of wear and tear or damage to the moving structures, to the component parts, all anchoring points, including cables and any accessible connections. Keep any hinges, moving joints and slide rails properly lubricated. Perform functional checks on the photocells and sensitive safety edges, every six months. Constantly clean the photocells' glass covers using a slightly water-moistened cloth; do not use solvents or chemicals that could damage the devices
- If repairs or modifications are required to the system, release the operator and do not use it until safety conditions have been restored
- Cut off the power supply before releasing the operator for manual openings and before any other operation, to prevent potentially hazardous situations. Read the instructions
- If the power supply cable is damaged, it must be replaced by the manufacturer or authorized technical assistance service, or in any case, by similarly qualified persons, to prevent any risk
- It is FORBIDDEN for users to perform any OPERATIONS THAT ARE NOT EXPRESSLY REQUIRED OF THEM AND WHICH ARE NOT LISTED in the manuals. For any repairs, modifications and adjustments and for extra-ordinary maintenance, CALL TECHNICAL ASSISTANCE
- Log the job and checks into the periodic maintenance log.

Further recommendations for all

- Keep away from and do not loiter near the barrier and mechanical moving parts
- Do not enter the barrier's area of operation when it is moving
- Do not counter the operator's movement as this could result in dangerous situations
- Always pay special attention to any dangerous points, which have to be labeled with specific pictograms and/or black and yellow stripes
- When using a selector switch or a command in maintained actions, keep checking that there are no persons within the operating range of any moving parts, until the command is released
- The barrier may move at any time and without warning
- Always cut off the power supply before performing any maintenance or cleaning.

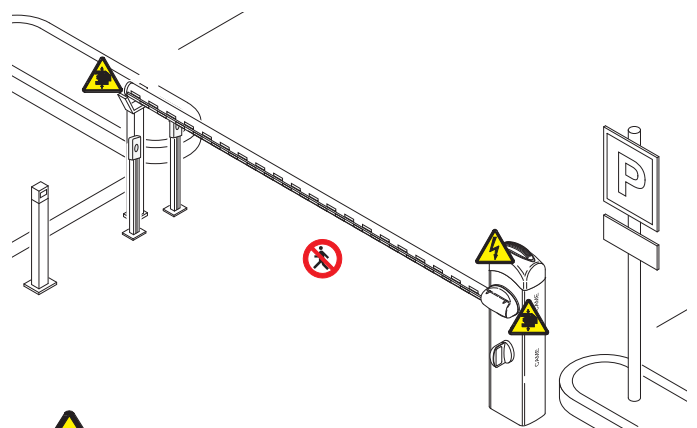

Danger of hand crushing





Danger! High voltage.



No transiting while the barrier is moving

LEGEND

-  This symbol shows which parts to read carefully.
-  This symbol shows which parts describe safety issues
-  This symbol shows which parts to tell users about.

REFERENCE REGULATIONS

Came S.p.A. the company is quality and environmentally certified by the ISO 9001 and the ISO 14001 respectively, for its management systems.

This product complies with the current regulations mentioned in the declaration of conformity.

DESCRIPTION

Automatic barrier with encoder, made of varnished galvanized steel and set up to fit accessories.

Intended use

The barrier is designed for use in private and public parking facilities, in residential settings and for high-rates of vehicle traffic.

 Any installation and/or use other than that specified in this manual is forbidden.

Limits to use

Type	G2080EZ
Maximum clearance width of the passage (m)	7.60

Technical data

Type	G2080EZ
Protection rating (IP)	54
Power supply (V - 50/60 Hz)	230 AC
Power supply motor (V)	24 DC
Max draw (A)	15
Power rating (W)	300
Torque (Nm)	600
Opening time a 90° (s)	4 ÷ 8
Duty cycle	INTENSIVE USE
Operating temperature (°C)	-20 ÷ +55
Reduction ratio (i)	1/202
Insulation class	I
Weight (kg)	91

Dimensions (mm)

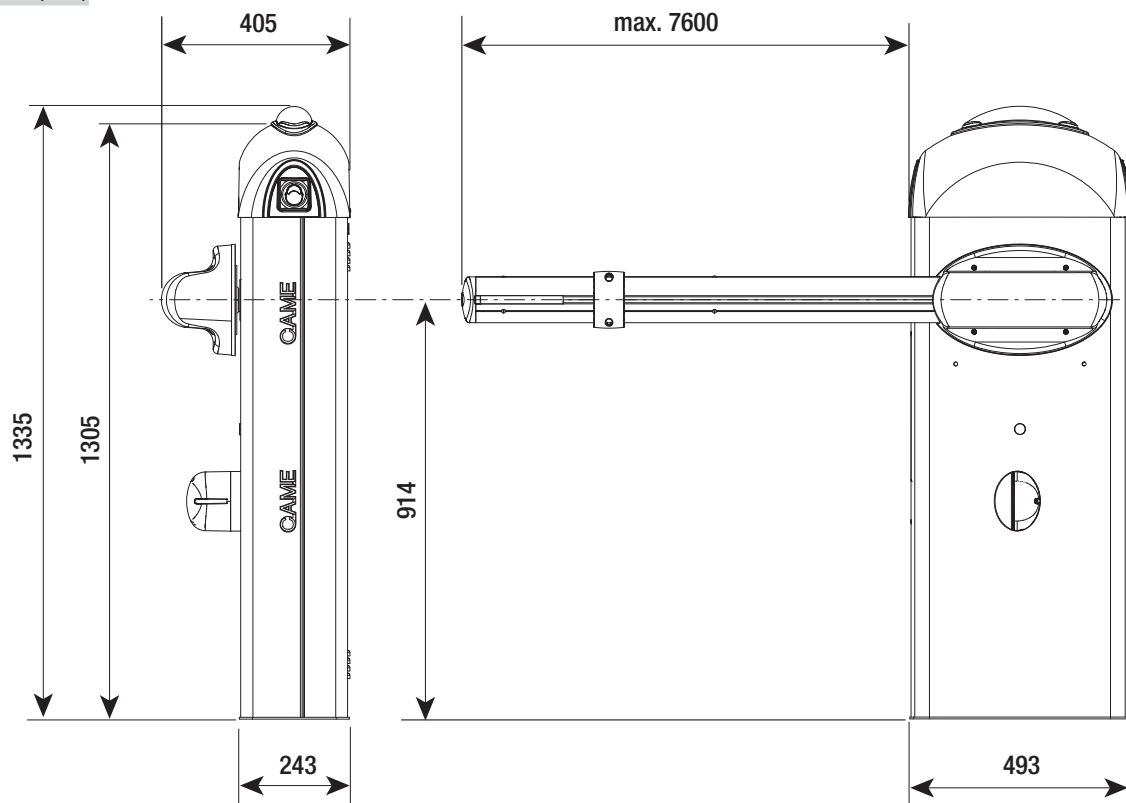

Description of parts

1. Dome
2. Motor-shaft plate
3. Mid plate
4. Boom-attachment cover
5. Protective casing shear proof
6. Cabinet
7. Set up for fitting accessories
8. Control panel
9. Lever arm
10. Boom adjustment buffer
11. Transmission rod
12. Gearmotor with encoder
13. Inspection hatch
14. Anchoring plate
15. Anchoring bracket
16. EMC01 filter

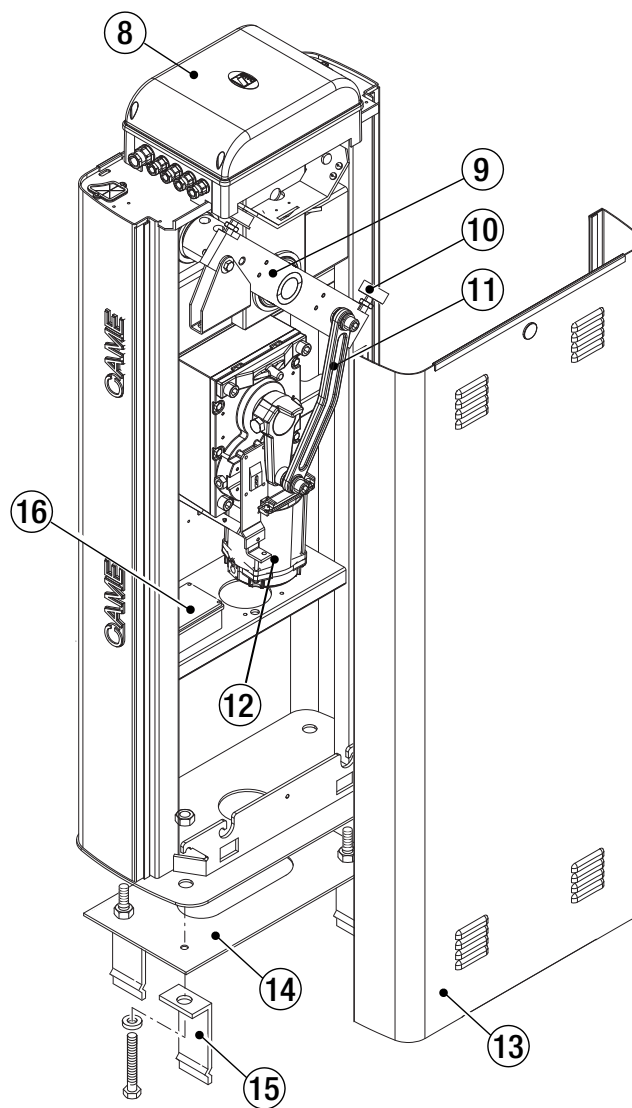
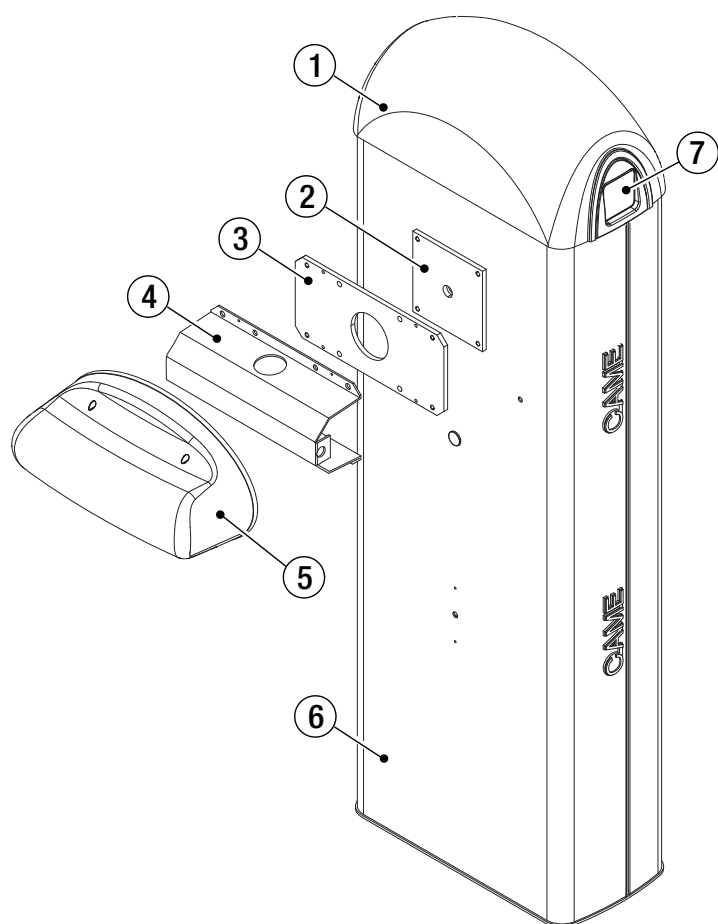

Standard installation

1. Barrier with boom
2. Reflective strips
3. Boom joint
4. Luminous cord
5. Flashing light
6. Antenna
7. Key-switch selector
8. Photocell casing
9. Photocell
10. Small photocell post
11. Fixed rest
12. Coil
13. Control device post
14. Control device (keypad selector, transponder sensor)

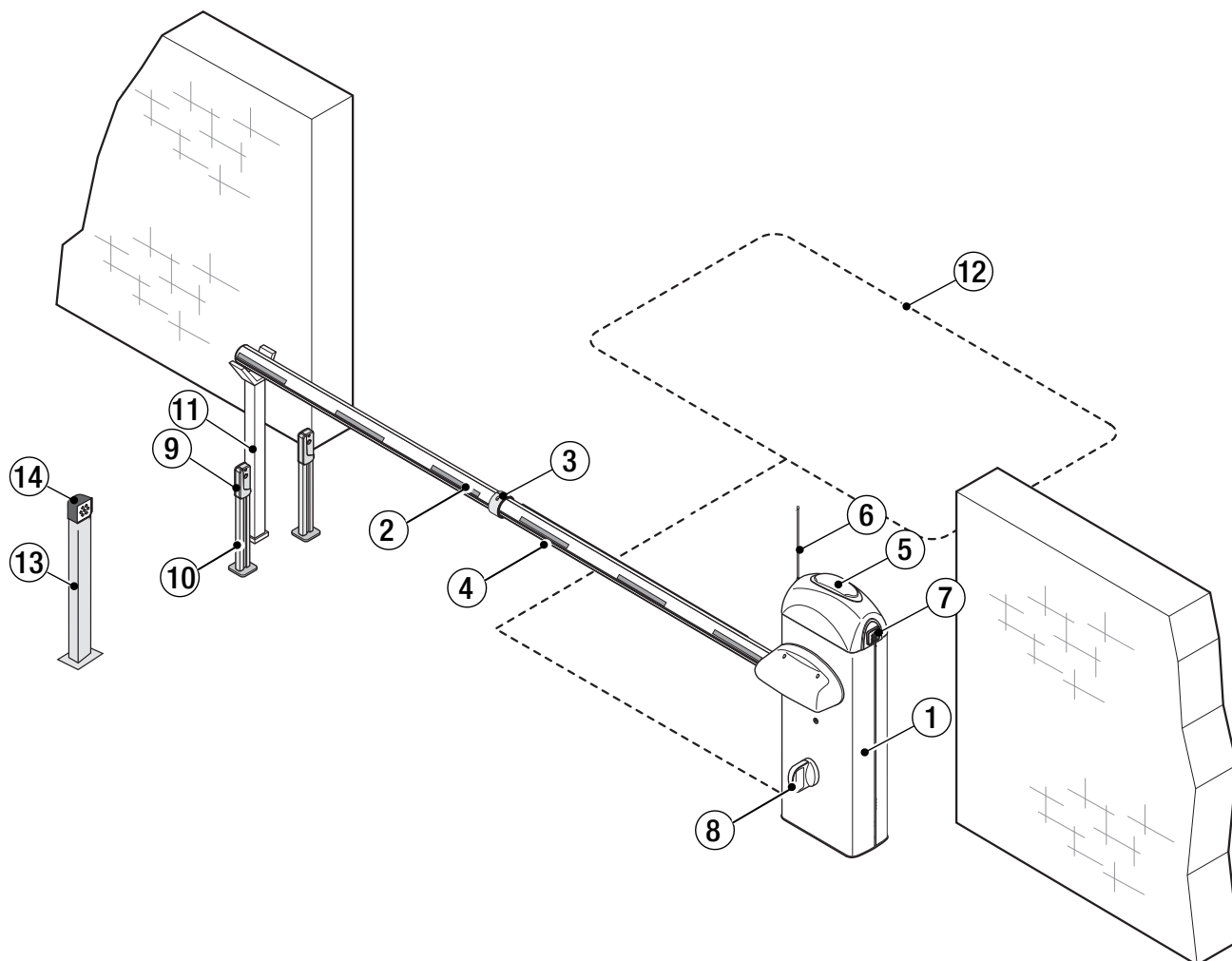

GENERAL INSTRUCTIONS FOR INSTALLING

△ Only skilled, qualified staff must install this product.

Important! Using original CAME control and safety devices and accessories ensures easy installation and system maintenance.

Preliminary checks

△ Before beginning, do the following:

- make sure the plate is anchored to a solid spot;
- make sure you have set up a suitable dual pole cut off device along the power supply that is compliant with the installation rules. It should completely cut off the power supply according to category III surcharge conditions (that is, with minimum contact openings of 3 mm);
- ⚠ Make sure that any connections inside the casing (ones that ensure continuity to the protection circuit) are fitted with additional insulation with respect to those of other electrical parts inside;
- set up suitable tubes and conduits for the electric cables to pass through, making sure they are protected from any mechanical damage.

Tools and materials

Make sure you have all the tools and materials you will need for installing in total safety and in compliance with applicable regulations. The figure shows some of the equipment installers will need.

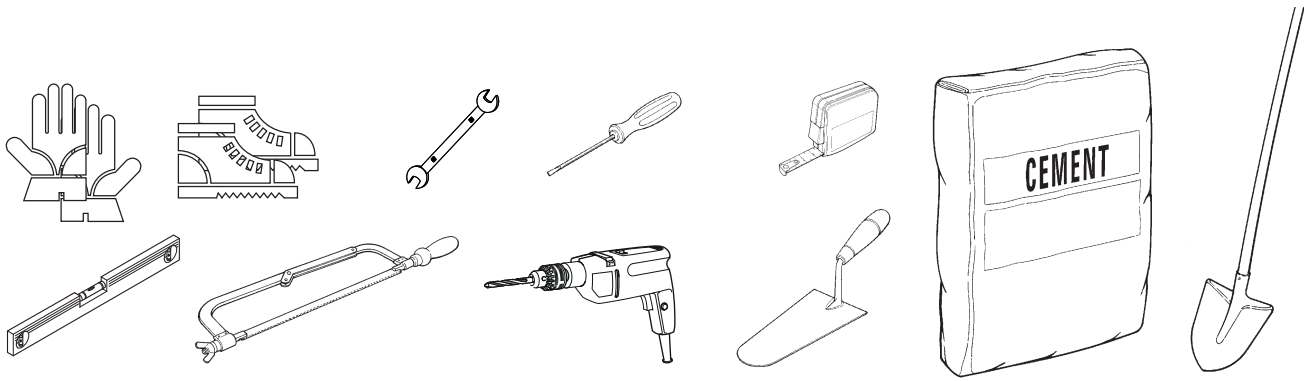

Cable types and minimum thicknesses

Connection	Cable type	Cable length 1 < 10 m	Cable length 10 < 20 m	Cable length 20 < 30 m
Power supply 230 V AC		3G x 1.5 mm ²	3G x 2.5 mm ²	3G x 4 mm ²
Flashing light	FROR CEI 20-22	2 x 0.5 mm ²	-	-
Photocell transmitters			2 x 0.5 mm ²	
Photocell receivers	CEI EN 50267-2-1		4 x 0.5 mm ²	
Command and safety device			2 x 0.5 mm ²	
Antenna	RG58		max 10 m	
Paired or CRP (Came Remote Protocol)	UPT CAT 5		max 1000 m	
Metal mass detector			(see product literature)	

📖 If cable lengths differ from those specified in the table, establish the cable sections depending on the actual power draw of the connected devices and according to the provisions of regulation CEI EN 60204-1.

For multiple, sequential loads along the same line, the dimensions on the table need to be recalculated according to the actual power draw and distances. If connecting products that are not contemplated in this manual, see the literature accompanying said products

INSTALLATION

⚠ The following illustrations are mere examples. Consider that the space available where to fit the barrier and accessories will vary depending on the area where it is installed. It is up to each installer to select the most suitable solution.

⚠ Warning! Use hoisting equipment to transport and position the barrier.

During the set up and installing stages the barrier could be unstable and tip over. So, be careful to not lean on it until it is completely fastened.

Preparing the fastening plate.

⚠ If the flooring does not allow for a sturdy fastening of the entry unit, you will have to set up a cement slab.

Dig a hole for the foundation frame.

Set up the corrugated tubes needed for making the connections coming out of the junction pit.

📖 The number of tubes depends on the type of system and the accessories you are going to fit.

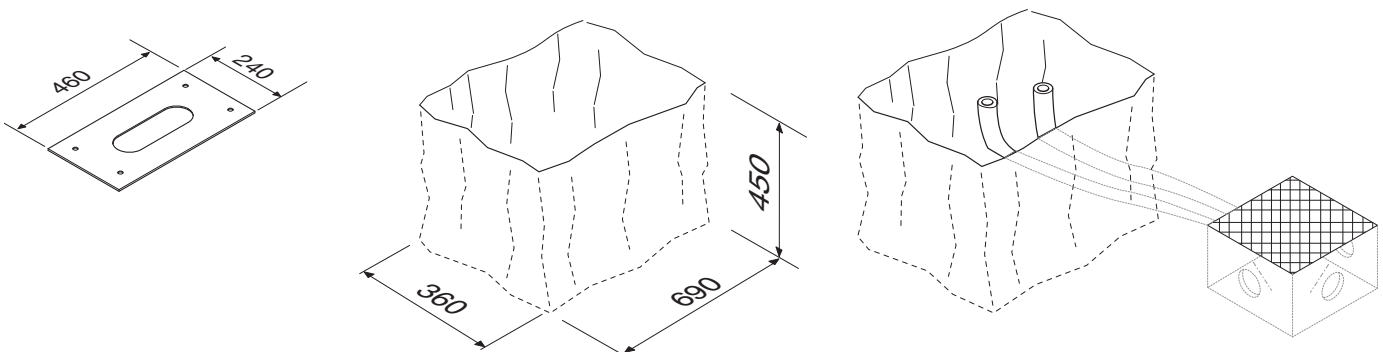

Set up a foundation frame that is larger than the anchoring plate and sink it into the dug hole.
 Fit an iron cage into the foundation frame to reinforce the concrete.
 Assemble the four anchoring brackets to the anchoring plate.

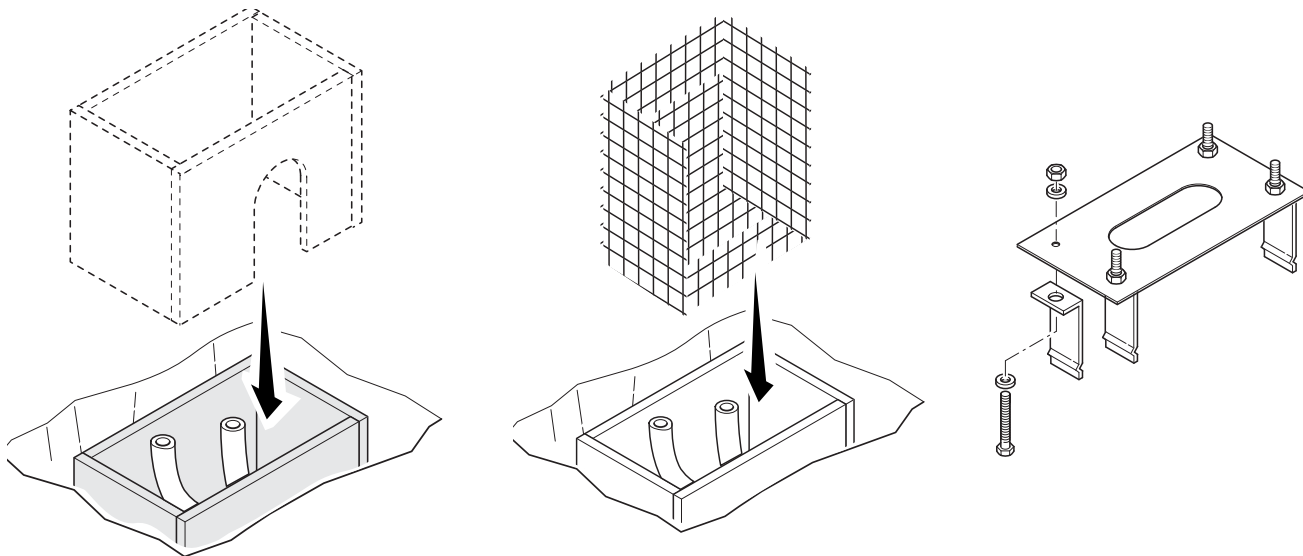

Place the plate over the iron cage.
 Fill the foundation frame with concrete. The base must be perfectly level with the bolts which are entirely above surface.
 Wait at least 24 hrs for the concrete to solidify.
 Remove the foundation frame.

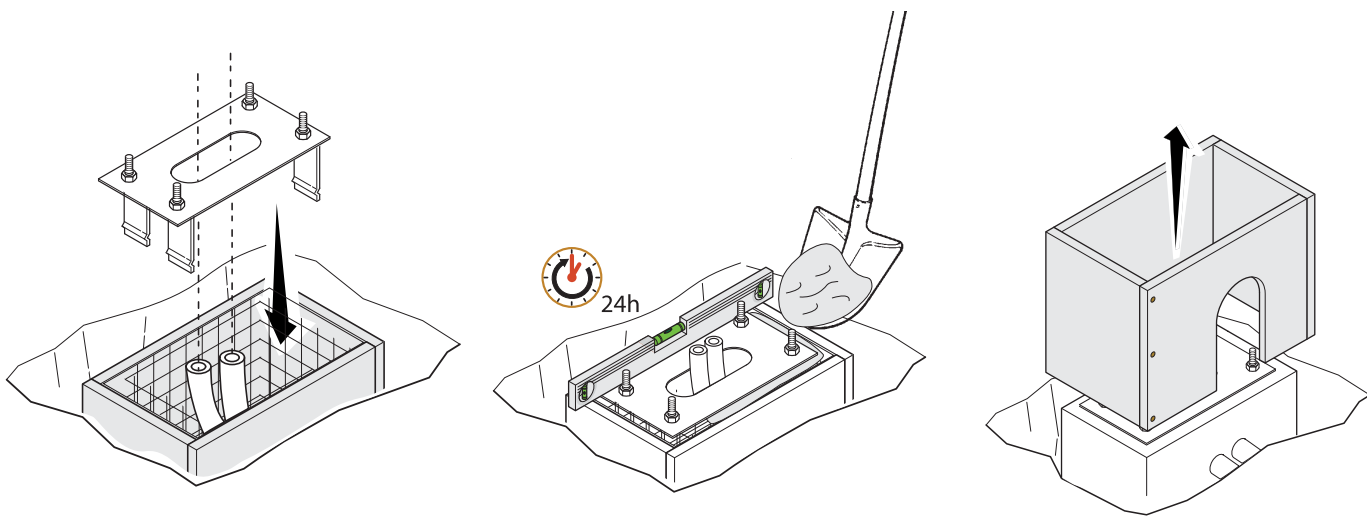

Fill the hole with earth around the concrete block.
 Remove the nut and washer from the bolts
 Fit the electric cables into the tubes so that they come out about 600 mm.

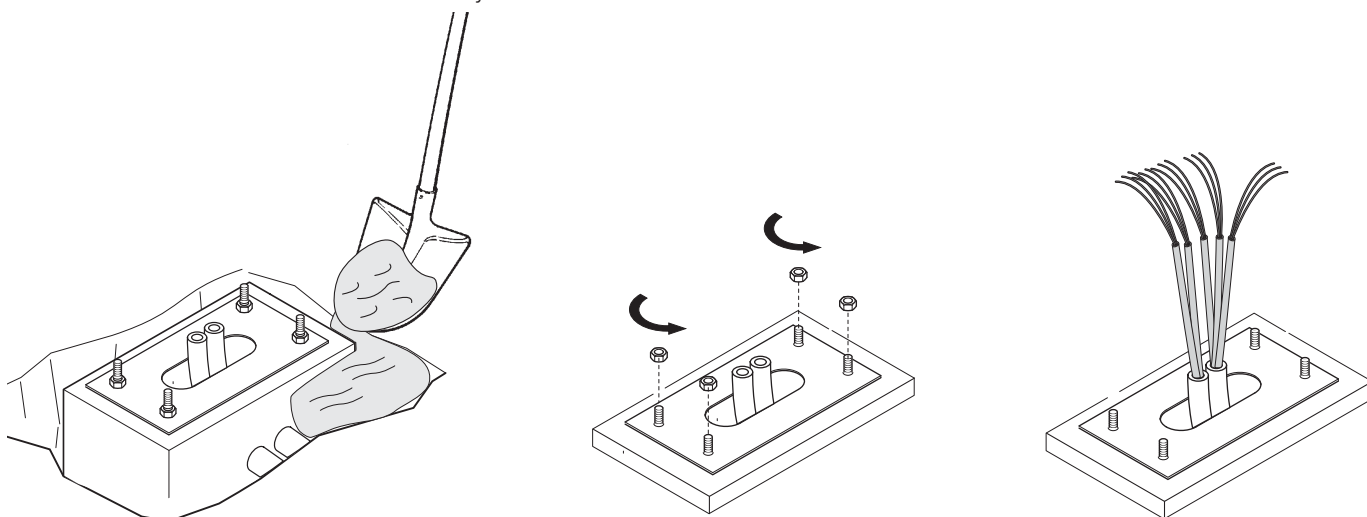

Preparing the barrier

Fit the key into the lock and turn it counter clockwise ❶, lift the dome and remove the inspection hatch ❷.

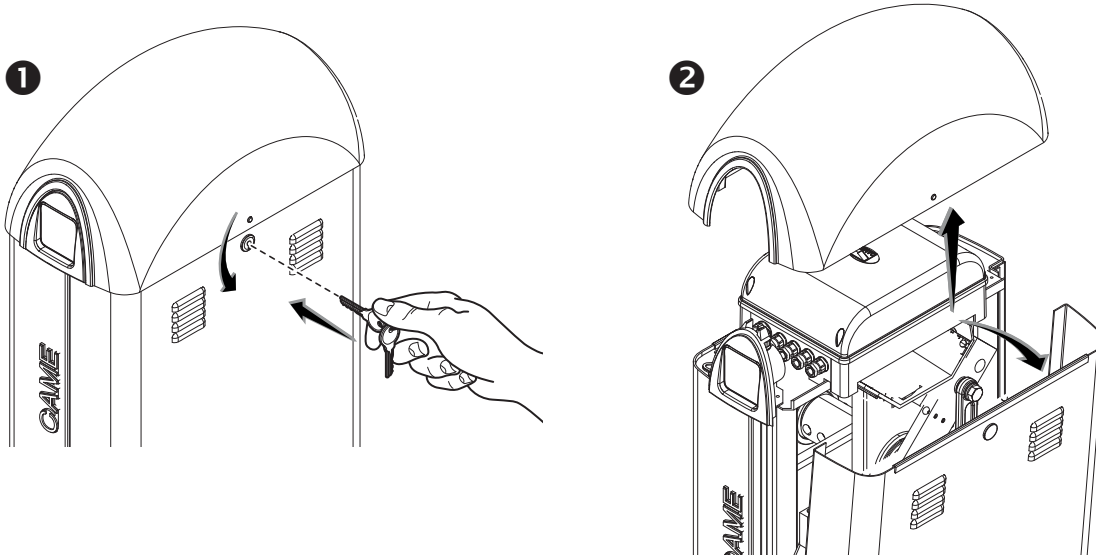

⚠ Warning! The barrier is set up for installing on the left.
When installing on the right, invert the boom's opening direction, as follows:

- loosen the motor arm headless screw, remove the spring attaching bracket and the lever arm transmission rod ❶;
- turn the lever arm by 90° ❷;
- fasten the spring attaching bracket to the transmission rod on the part opposite the lever arm and tighten the headless screw ❸;
- invert motor phase M with N ❹.

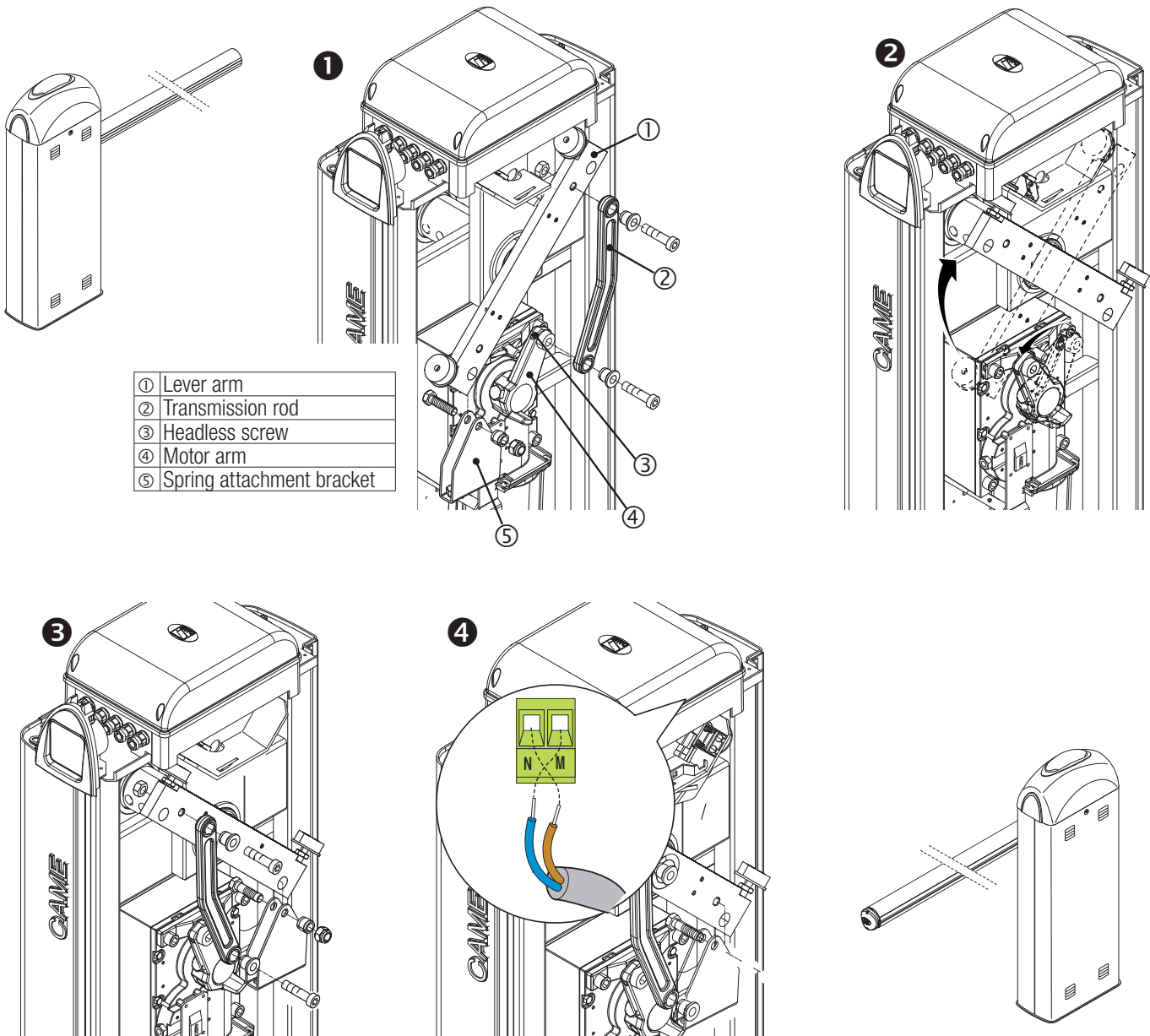

Installing the barrier

 The cabinet should be installed with the inspection hatch on the most accessible side to make any adjusting easier. Place the cabinet on the anchoring plate and fasten it using nuts and washers.

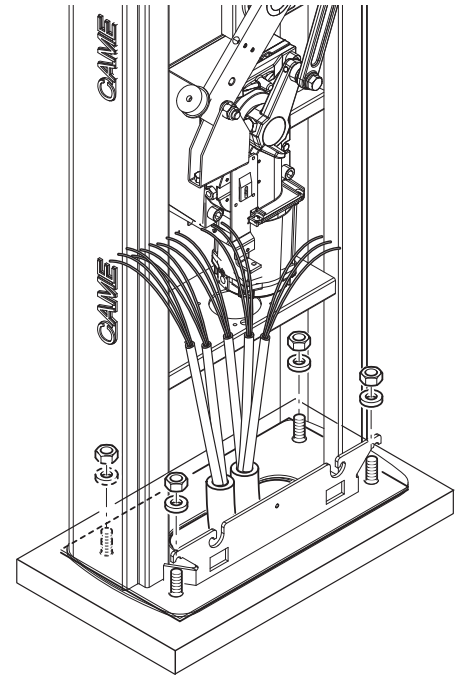
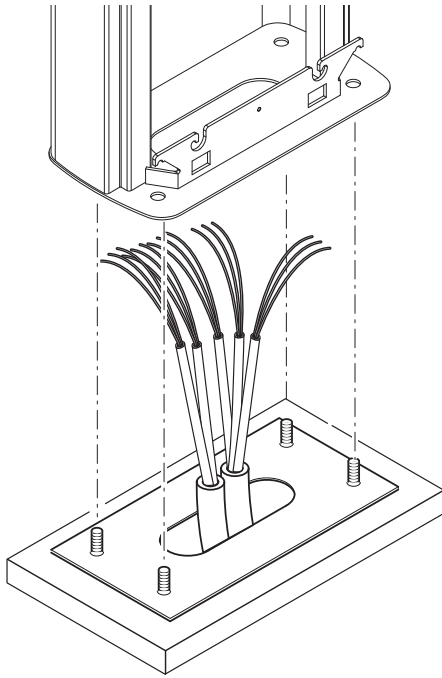

Assemble the boom-attaching cover, the mid plate and motor-shaft plate with a screw. Leave the screw loose to then facilitate fitting the boom. Fit the boom into the boom-attachment cover and fasten it using the screws.

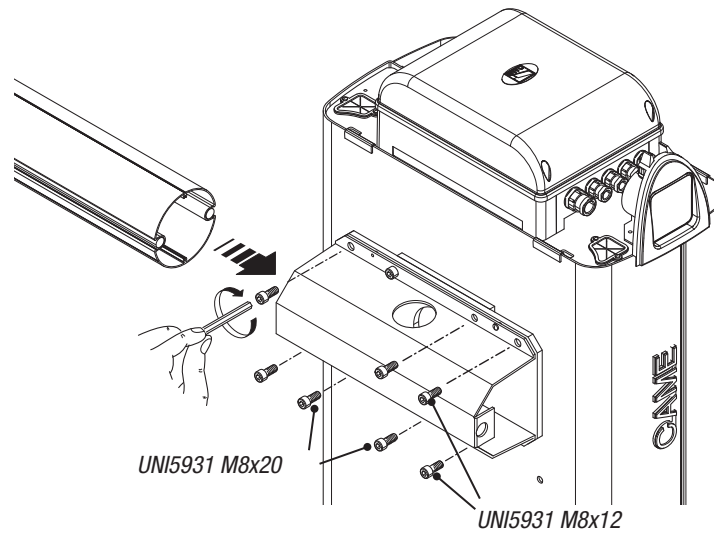
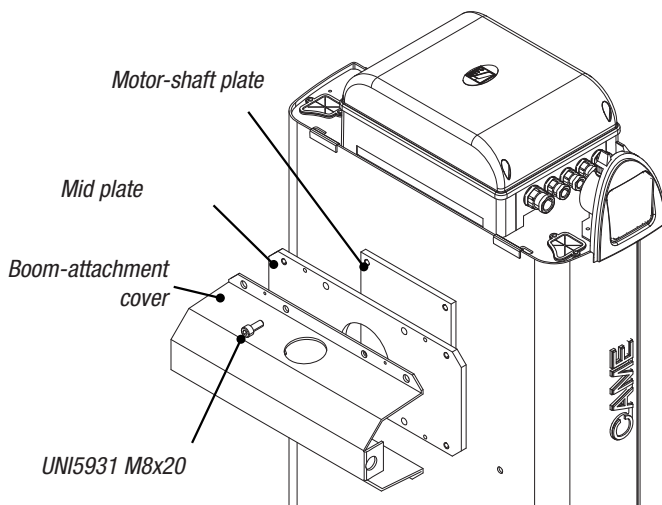

Cut the groove covering profiles to measure and fit them into either side. Use the screws to fasten the boom endcap.

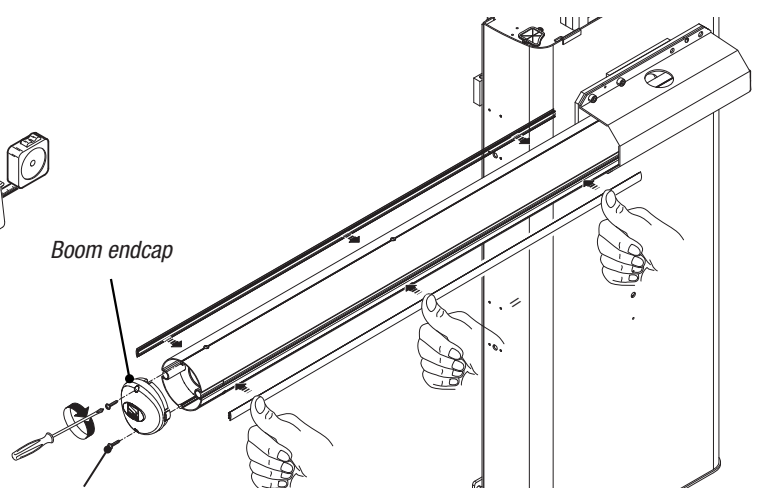
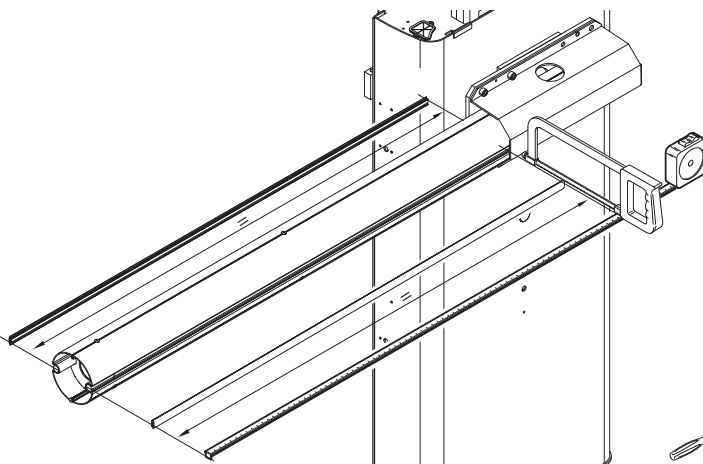

Fit the anti-shearing protective cover onto the boom-attachment cover and fasten it with screws.

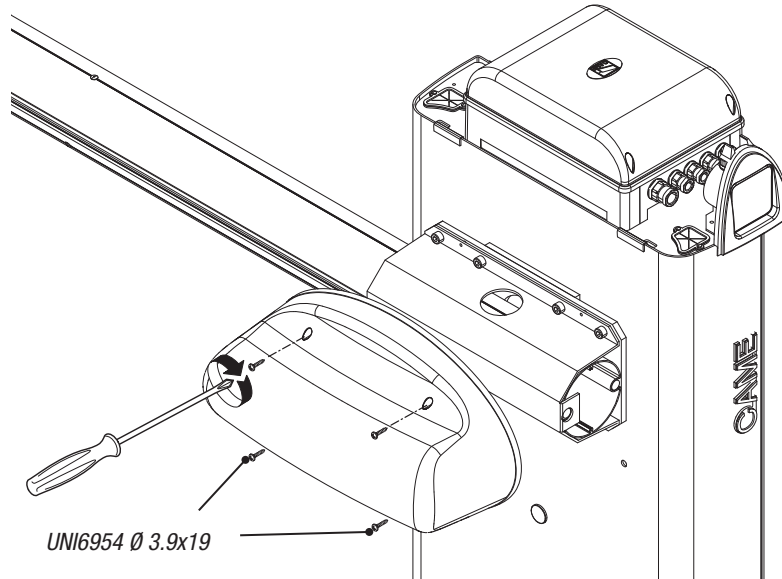

Balancing the boom

Before balancing the boom, check on the table below for congruences between the chosen spring, accessories and passage clearance.

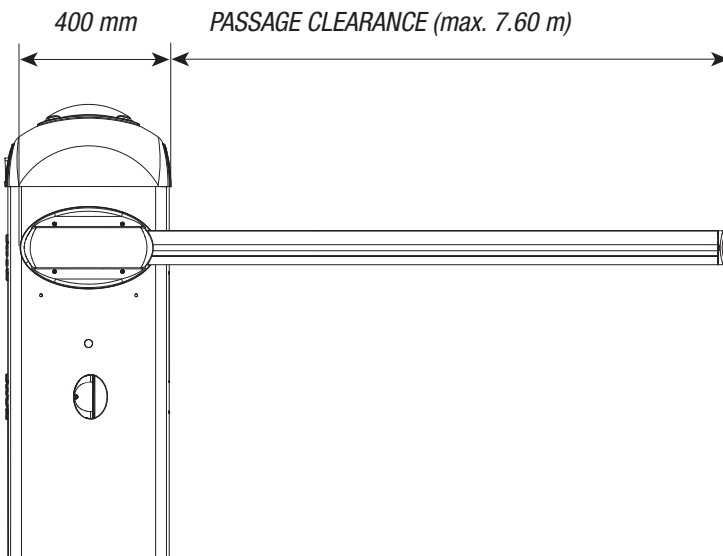

	A Spring 001G02040 Ø 40 mm		B Spring 001G04060 Ø 50 mm		C Spring 001G06080 Ø 55 mm						
BOOM LENGTH (m)	2 ÷ 2.5	2.5 ÷ 3	3 ÷ 3.5	3.5 ÷ 4	4 ÷ 4.5	4.5 ÷ 5	5 ÷ 5.5	5.5 ÷ 6	6 ÷ 6.5	6.5 ÷ 7	7 ÷ 7.6
Boom	A	A	A	AA	B	AB	AB	BB	BB	BC	CC
Boom with swing-leg 001G02808	A	A	AA	AA	AB	AB	BB	BB	BC	CC	
Boom with luminous cord 001G28401	A	A	AA	AA	AB	AB	BB	BB	BC	BC	CC
Boom with 001G02808 swing rest and 001G28401 luminous cord	A	AA	AA	B	AB	BB	BB	BC	CC	CC	
Boom with skirt 001G0465	A	A	AA	B	AB	BB	BB	BC	BC	CC	
Boom with 001G0465 skirt and 001G028401 luminous cord	A	AA	AA	AB	AB	BB	BB	BC	CC	CC	

* By boom we mean a boom complete with transparent groove cover and cap.

⚠ WARNINGS!

001G02802 Cannot be used on barriers fitted with the 001G0465 skirt or 001G02808 swing rest

001G02808 For passage width clearances of up to max. 7 m.

001G02807 MUST be used with passage width clearances of over 7 m.

001G0465 - 001G02808 Cannot be used together.

Release the gearmotor and position the boom vertically. Lock the gearmotor again.

Install the spring into the barrier in the following way:

- fit a UNI5739 M12x70 screw into the attachment bracket and tighten the UNI5588 M12 nut to the screw ❶.
- tighten the screw into the spring ❷;
- tighten the eyelet tie rod below the spring ❸.

Hook the tie rod to the anchoring bracket.

Perform the same procedure for a possible second spring.

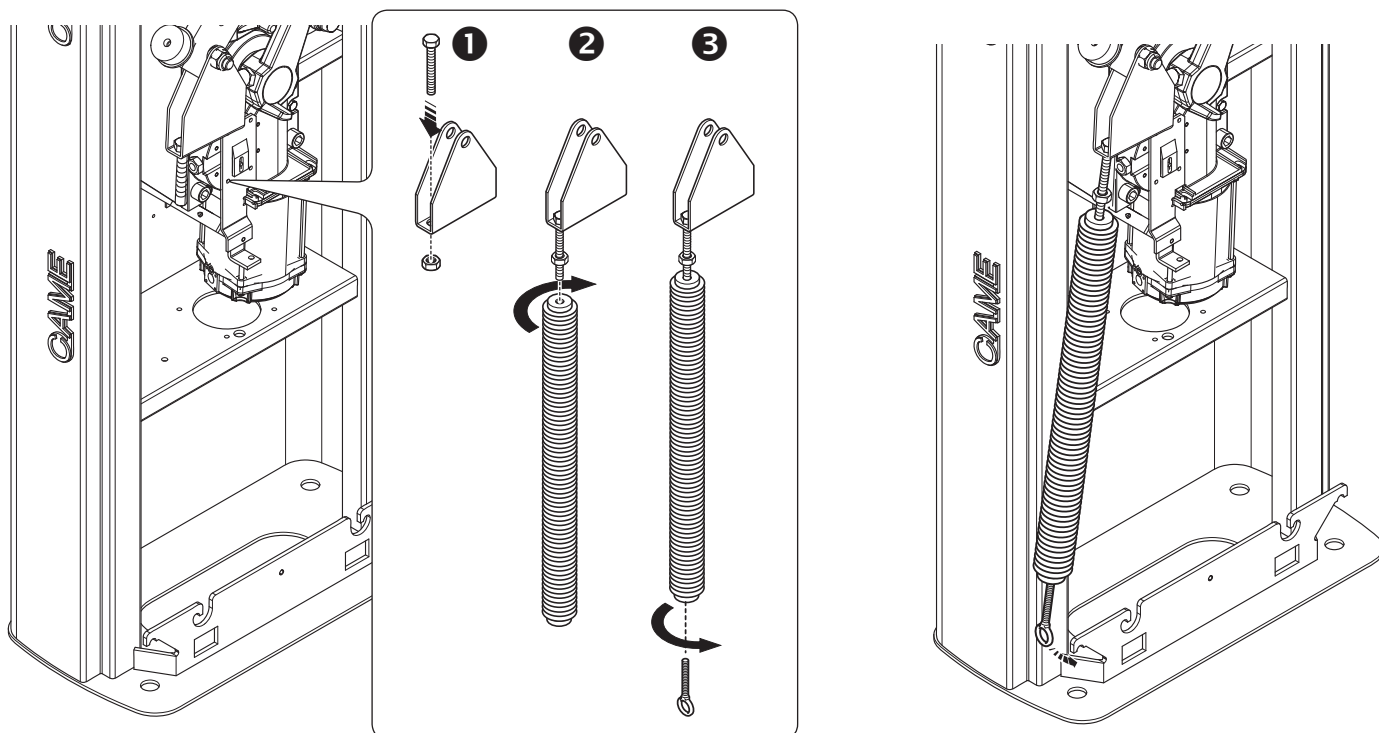

Release the gearmotor and manually turn the spring to increase or decrease tautness. The spring should stabilize at 45°.

Fasten the counter nut and lock the gearmotor again.

📖 Check the proper working state of the spring.

With the boom raised vertically the spring is not taut.

With the boom lowered horizontally the spring is taut.

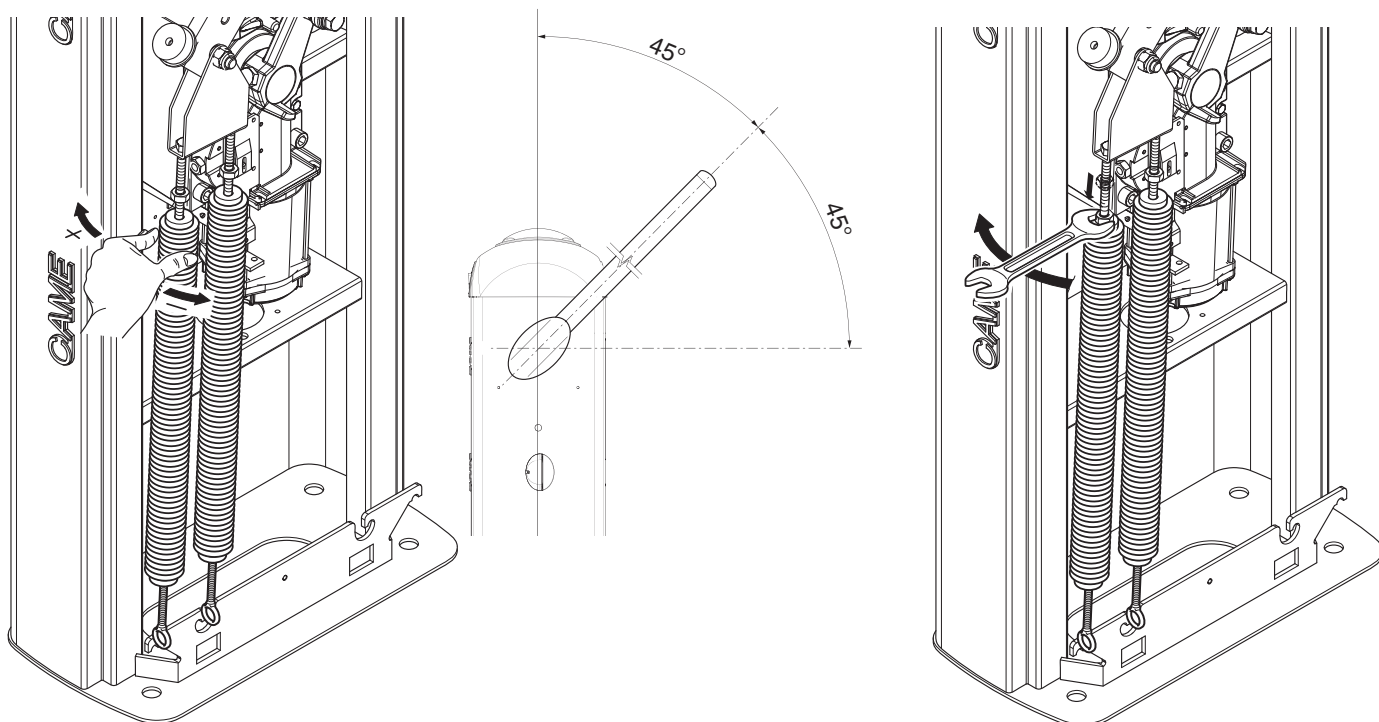

ELECTRICAL CONNECTIONS

⚠ Warning! Before working on the control panel, cut off the main current supply and, if present, remove any batteries.

Power supply to control panel and control devices: 24 V AC/DC.

Functions on input and output contacts and time and user management details, are set up and viewable on the control panel's display.

All connections are quick-fuse protected.

📖 **Important!** Fit a ferrite, of the type FAIR-RITE material 31 SPLIT ROUND CABLE ASSEMBLY mod 0431177081, to the inside of the control panel and onto the control, warning and safety device cables.

FUSE TABLE	ZL39
LINE - Line	3.15 A-F = 120 V 1.6 A-F = 230 V
C.BOARD - Card	1 A-F
ACCESSORIES - Accessories	2 A-F

Description of parts

- Transformer
- Power supply terminals
- Transformer terminals
- Gearmotor terminal
- Encoder terminals
- Control board fuse
- Power supply on warning LED
- Programming warning LED
- Memory roll board connector
- Programming buttons
- Connector for the R700 / R800 card
- RSE board connector
- AF card connector
- Antenna terminal
- Terminals for control and safety devices
- Terminals for paired / alternate / CRP connections
- Keypad selector terminal
- Terminals for transponder devices
- Display
- Accessories fuse
- Line fuse
- Overheating protection terminals
- Ferrite

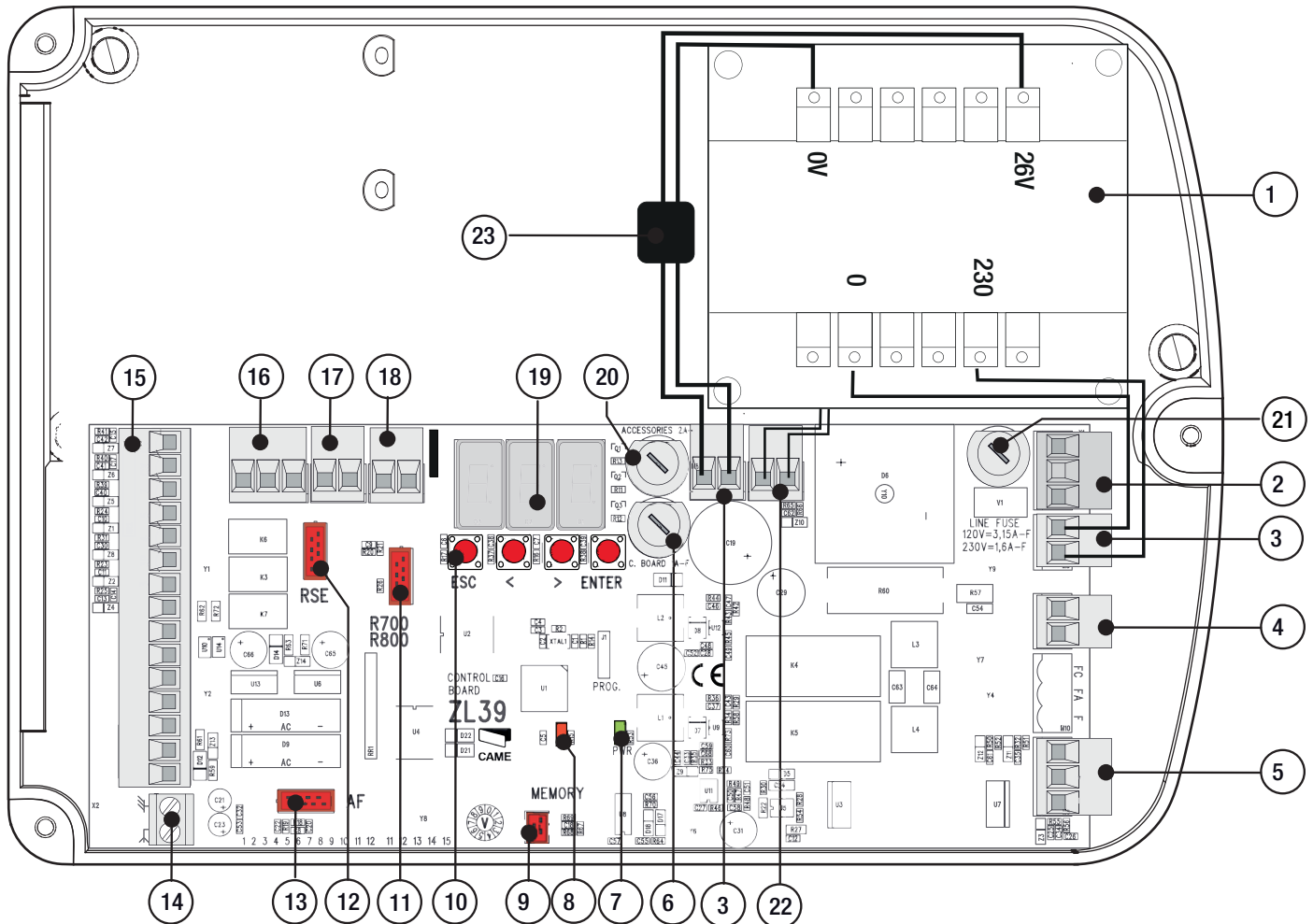

Power supply

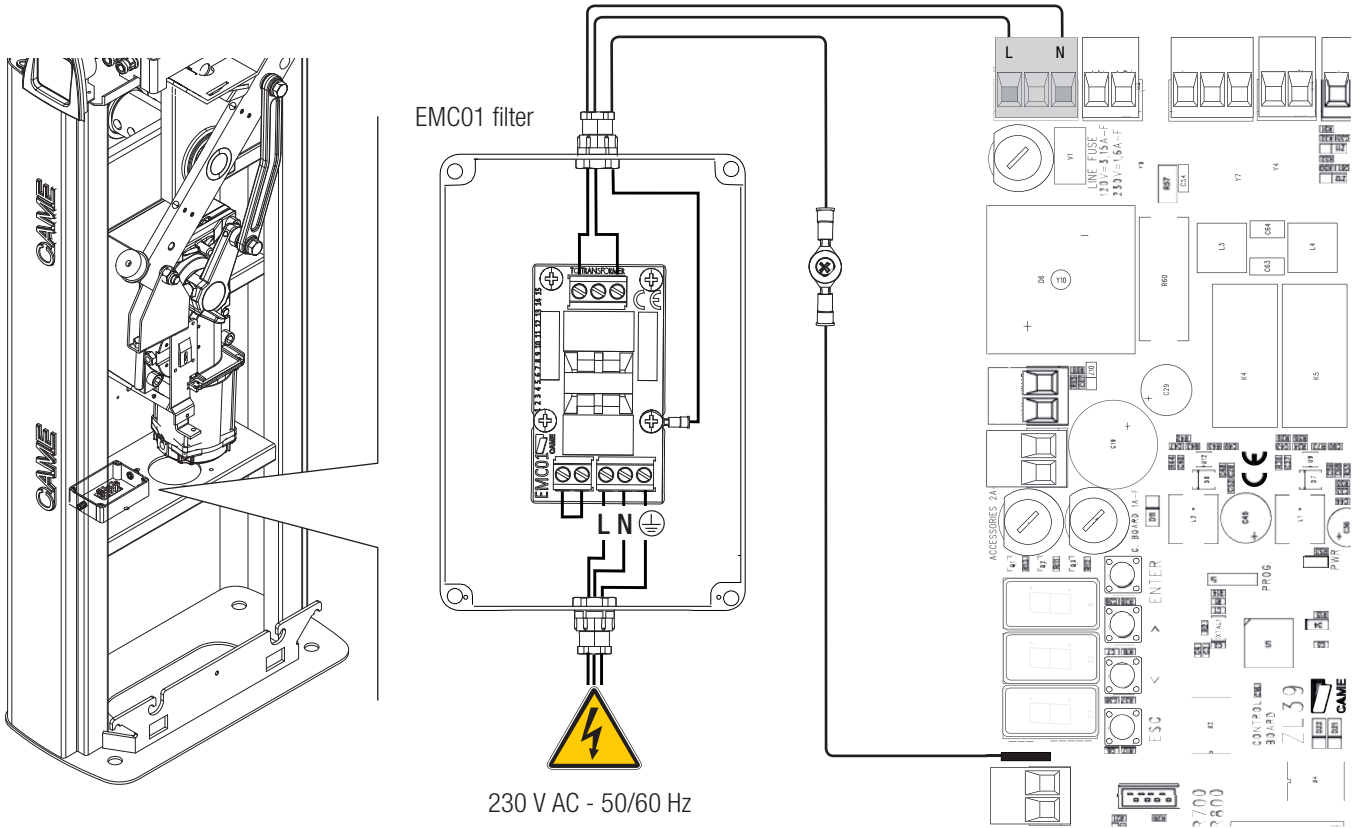

Terminals for powering up accessories:
 - a 24 V AC normally;
 - a 24 V DC when the emergency batteries are operating;
 Overall allowed power: 40 W

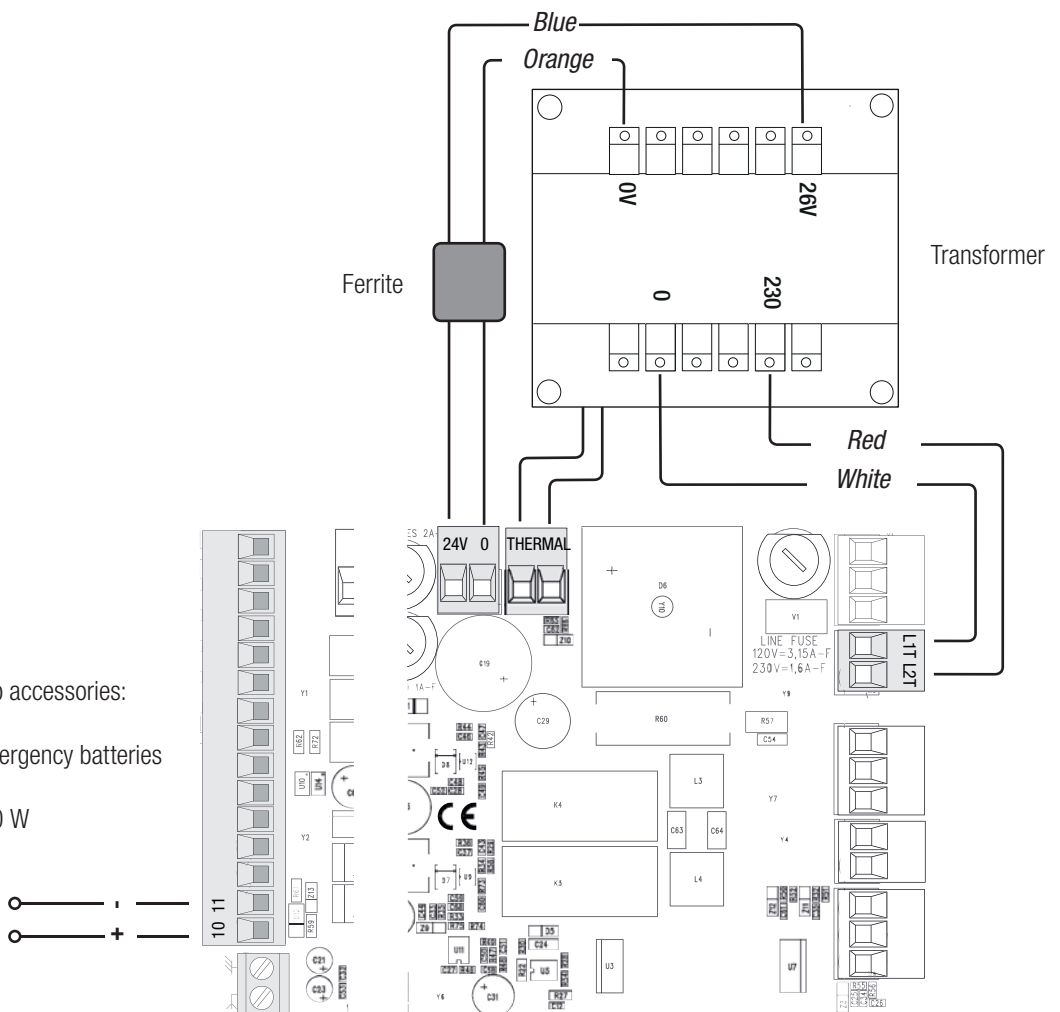

Factory wiring

The gearmotor is already connected.

To install the barrier on the right, follow the instructions in the PREPARING THE BARRIER.

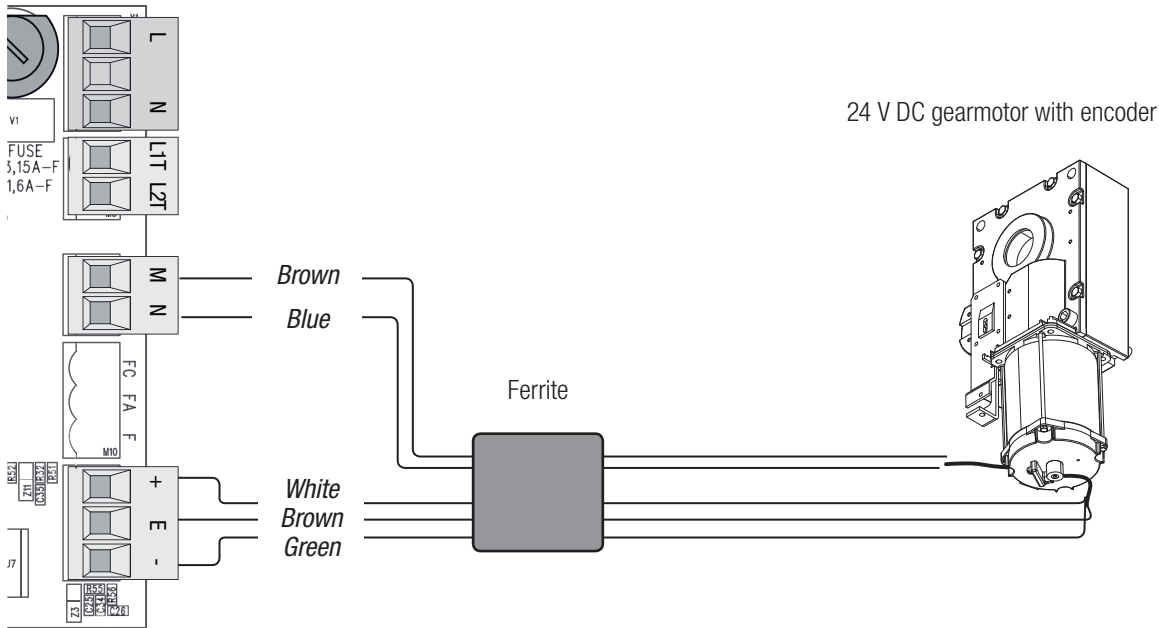

Warning devices

Barrier indicator light (contact rated for: 24 V AC - 3 W max).
It warns of the barrier status, see function F 10.

Luminous cord (Contact rated for: 24 V AC - 32 W max).
It flashes during the boom's opening and closing phases, see function F 15.

Flashing dome light (Contact rated for: 24 V AC - 25 W max).
It flashes during the barrier's opening and closing phases.
Alternatively, it is possible to connect a cycle or courtesy lamp. (Contact rated for: 24 V AC - 25 W max).
An auxiliary external light can be connected and placed anywhere to increase lighting in the driveway.
Cycle: it stays on from the moment the boom starts opening until it is fully closed (including the automatic closing time).
Courtesy: it stays on for an adjustable time of between 60 and 180 seconds.

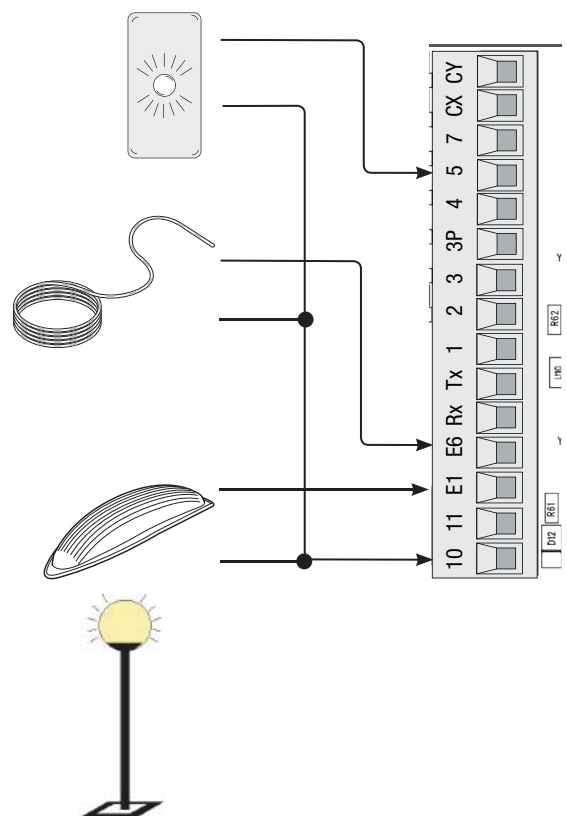

Command and control devices

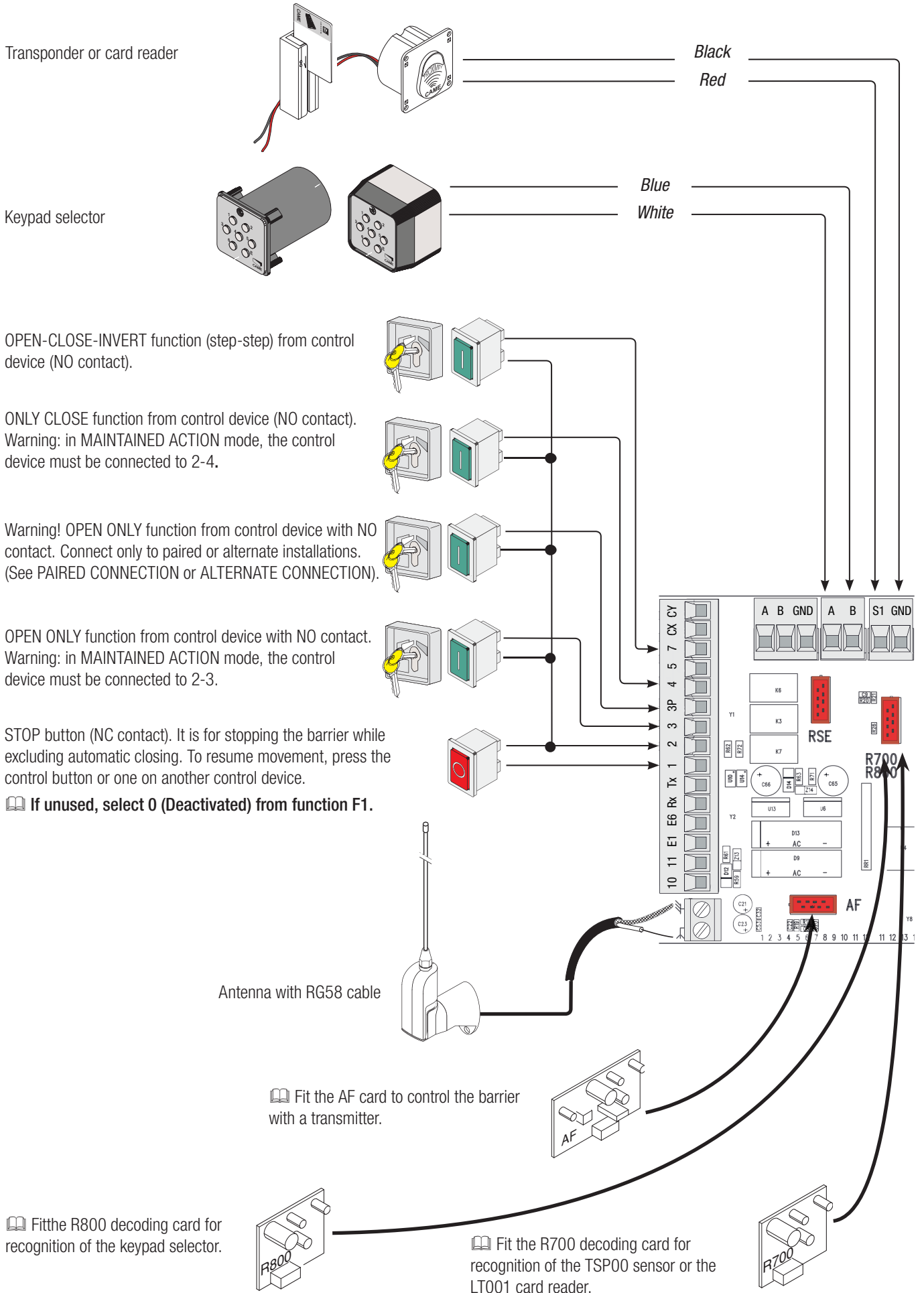

WARNING! For the system to work properly, before fitting any plug-in card, such as the AF or R800 one, YOU MUST CUT OFF THE MAIN POWER SUPPLY and, if present, disconnect any batteries.

Safety devices

Configure contact CX or CY (NC), input for safety devices such as photocells, that are EN 12978 regulation compliant. See CX input functions (Function F2) or CY (Function F3)-

C1 reopening while closing. When the boom is closing, opening the contact causes its movement to invert until fully opened;

C4 obstruction wait. Stopping the boom, if it is moving, with resumption of movement after the obstruction is removed.

C5 immediate closing. Closing the boom after a vehicle has passed through the operating area of the safety devices.

C9 immediate closing with obstruction wait when closing.

Closing the boom after a vehicle has passed through the operating area of the safety devices.

📖 During the closing phase, the devices also perform the function of **C4 obstruction wait**.

📖 If unused, contacts CX and CY should be deactivated during programming.

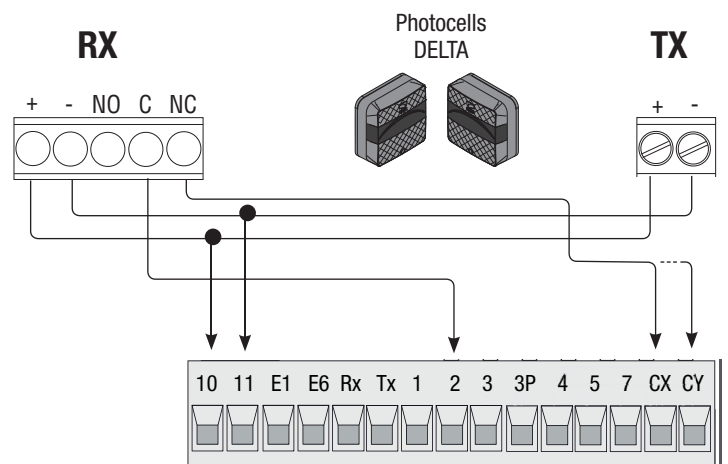
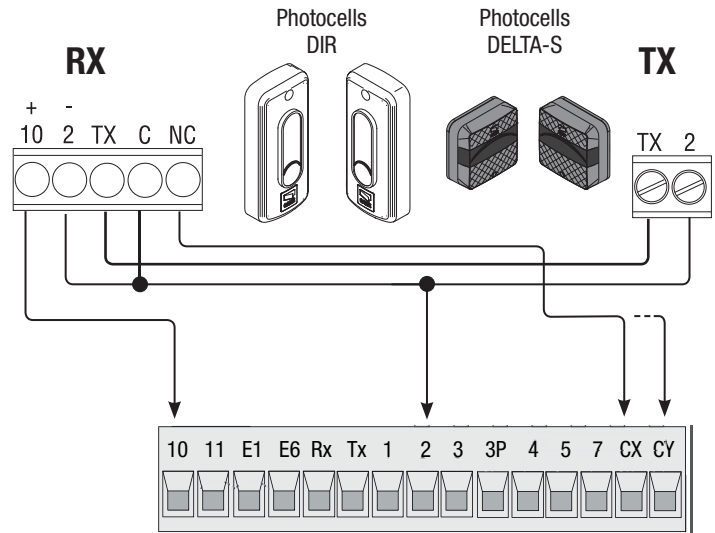

Photocell's safety connection

Upon each open or close command, the board verifies that the safety systems work. Any malfunction inhibits any command. Select, from Function F 5, on which inputs to activate.

DELTA

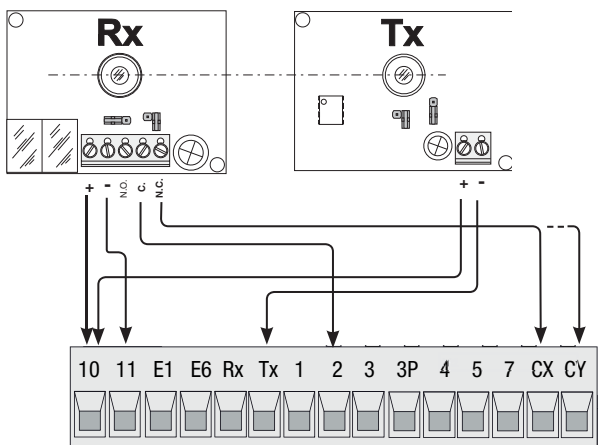

DIR / DELTA S

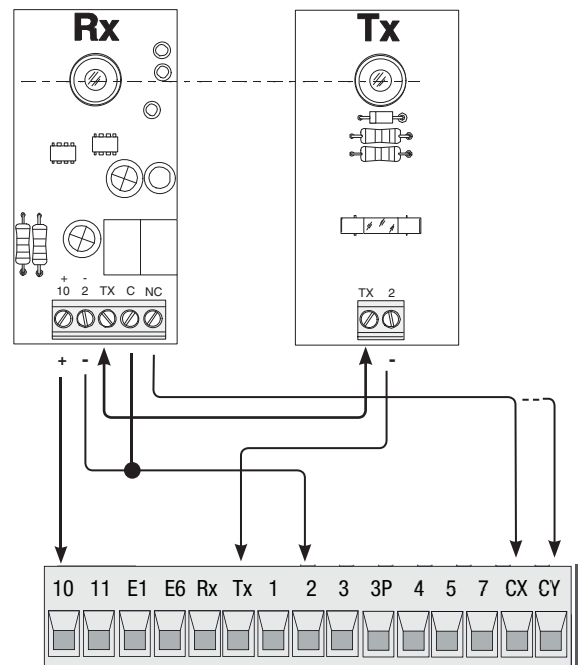

Sleep Mode

The Sleep mode function is for reducing energy consumption of the stand-by photocells.

Select 1 from function F 60.

DELTA

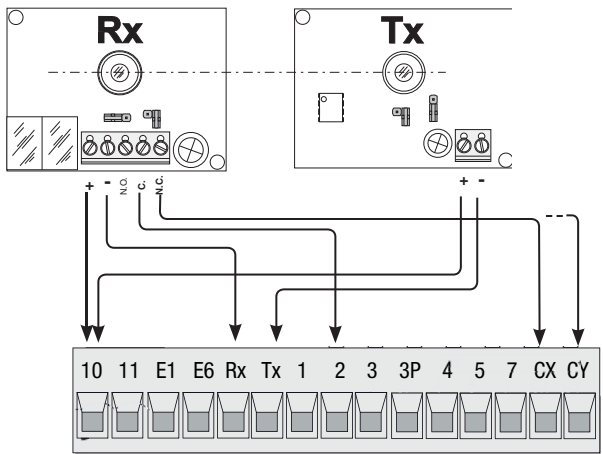

DIR / DELTA S

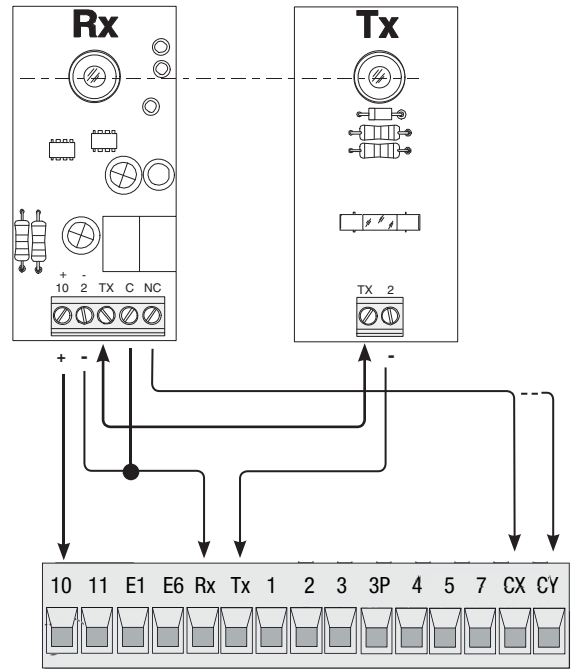

Connection with Came Remote Protocol (CRP) and for either paired or alternate operating mode

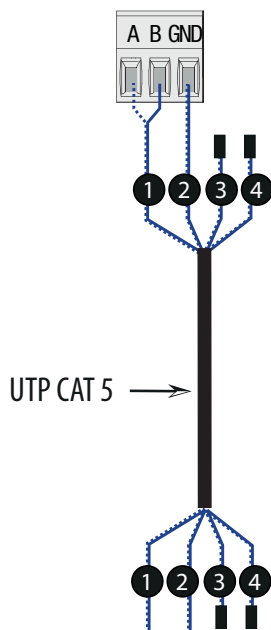

Serial RS485 connection to home automation system or for either paired or alternate barrier operating mode.

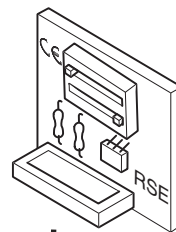

Fit the RSE card.

For the system to work properly, before fitting the control board, you **MUST CUT OFF THE POWER MAINS** and remove any emergency batteries.

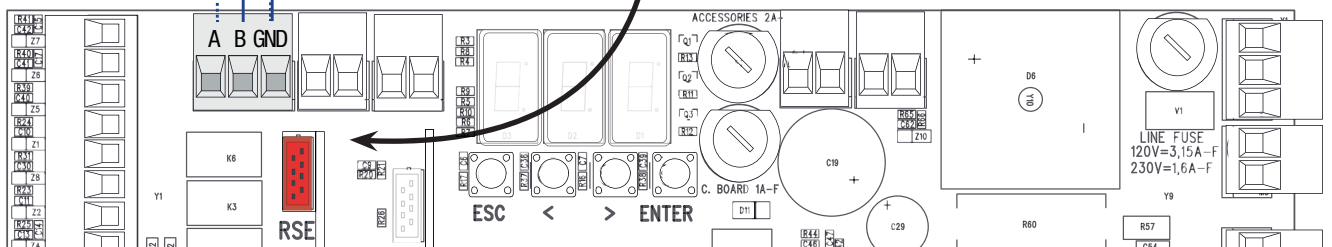

Establishing the endstop points

Close the inspection hatch and power up the system. Activate the barrier to check whether the boom is parallel to the road surface when closed and at about 89° when open.

△ The boom's opening and closing maneuvers must be performed with the inspection hatch closed.

To correct the boom's vertical position:

- lower the boom;
- open the inspection hatch;
- turn the opening mechanical stop clockwise to increase the boom's travel or counter clockwise to reduce it ❶.

Fasten the stop with a counter nut ❷.

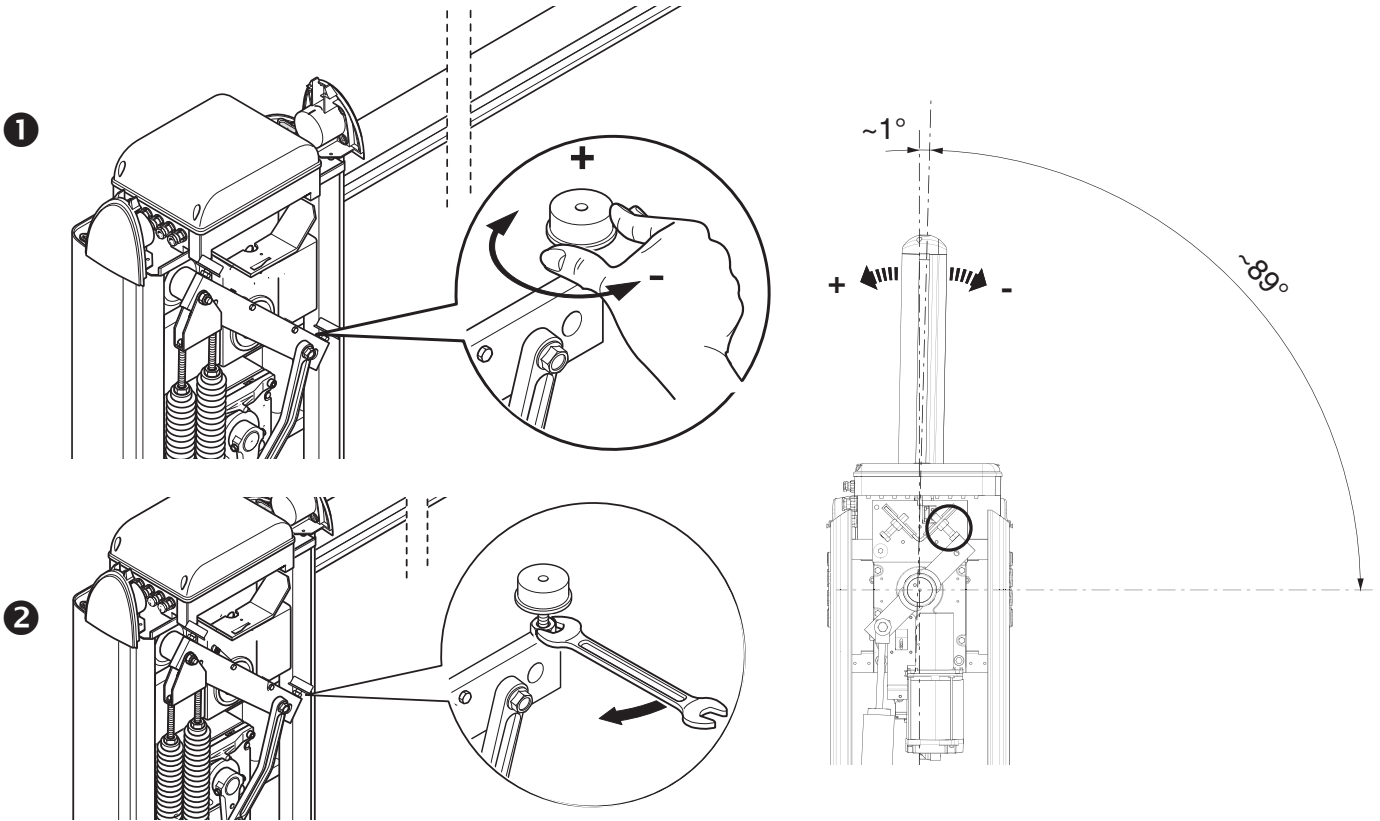

To correct the horizontal position:

- raise the boom;
- turn the mechanical closing stop clockwise to increase the boom travel or counter clockwise to reduce it ❸.

Fasten the stop with a counter nut ❹.

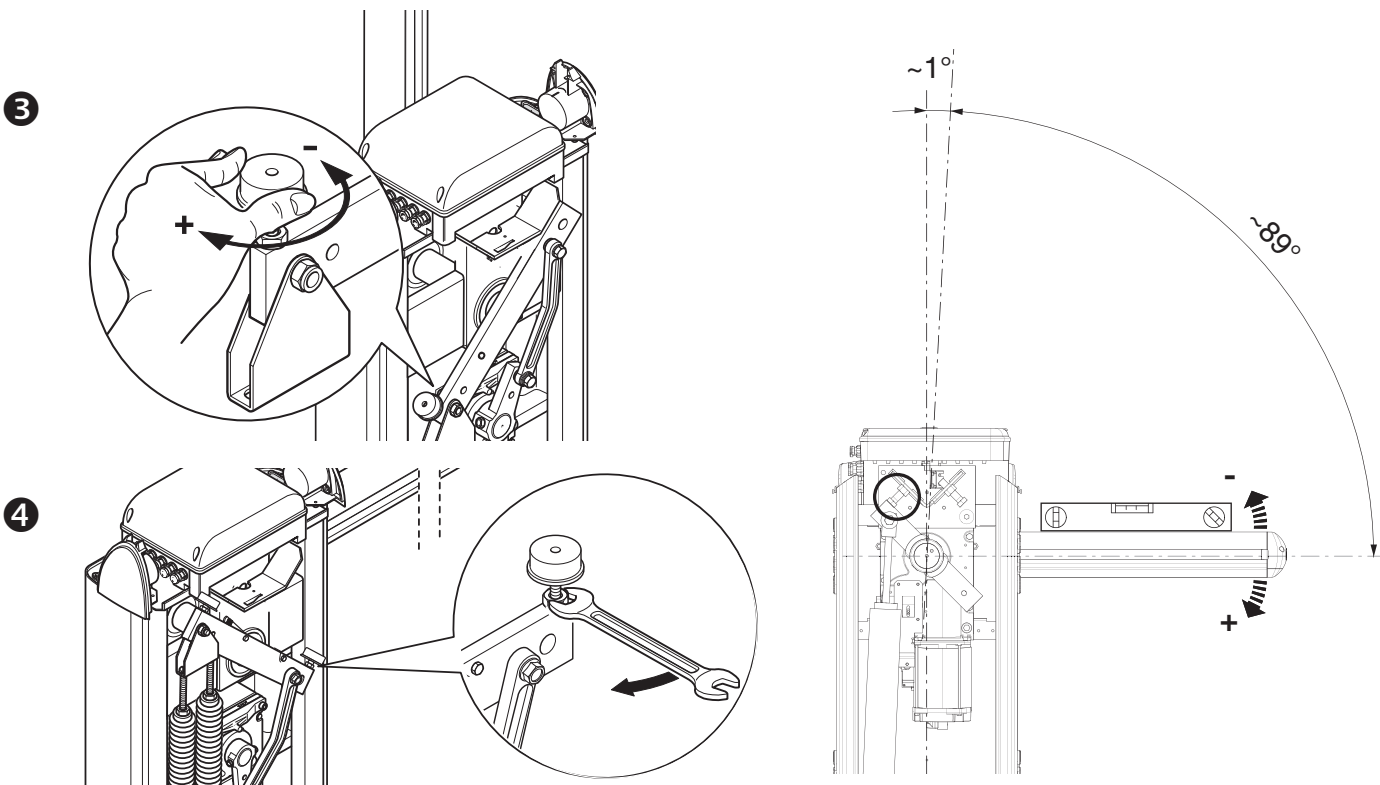

⚠ During programming, the barrier must not be moving.

Description of programming commands

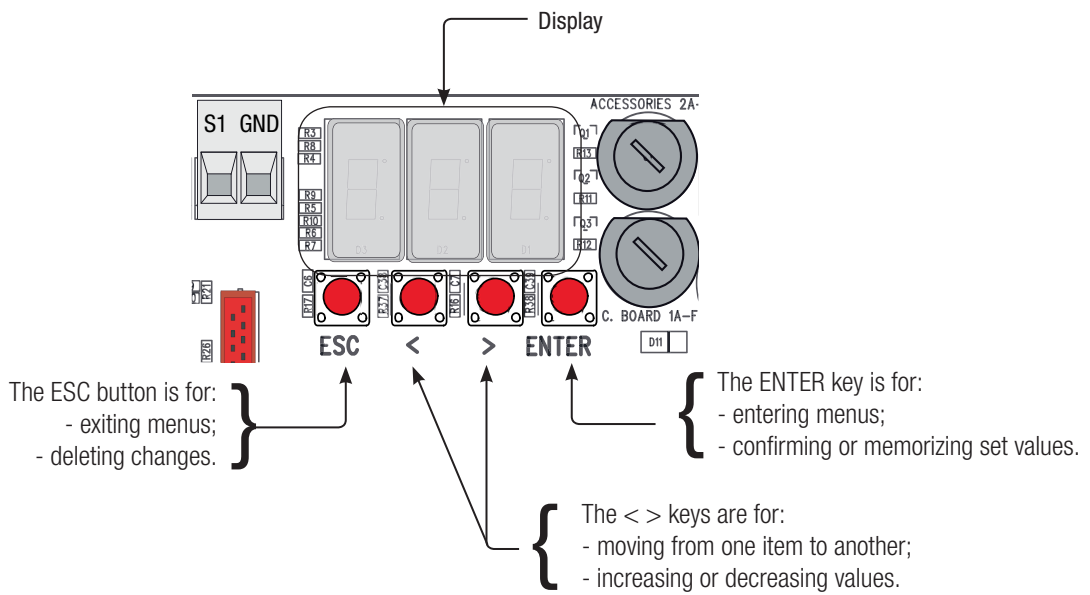

Browsing the menu

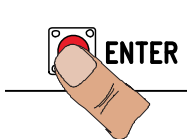

To enter the menu, keep the ENTER button pressed for at least one second.

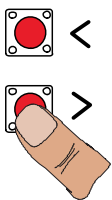
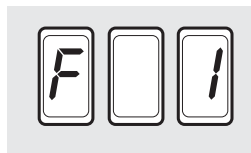

To select menu items, use the arrow keys ...

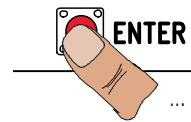
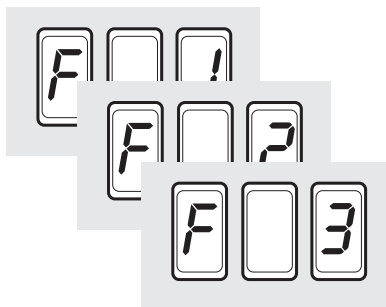

... then press ENTER

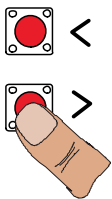

also for the submenus, use the arrow keys to select ...

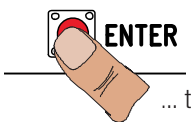
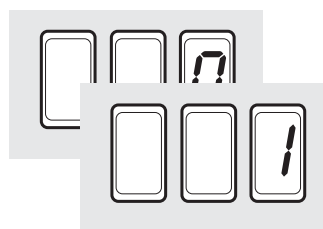

... then press ENTER

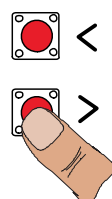

To increase or reduce the value use the arrows...

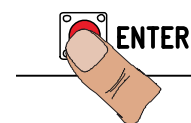
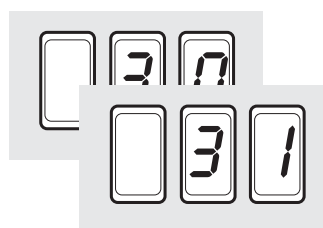

... the press ENTER to confirm ...



... to exit the menu, wait 10 seconds or press ESC.

Functions map

F 1	Total stop function (1-2)
F 2	Function associated to input CX
F 3	Function associated to input CY
F 5	Safety test function
F 6	Maintained action function
F 9	Obstruction detection with motor idle function
F 10	Warning light function
F 11	Encoder exclusion
F 14	Sensor type selection function
F 15	Intermittent luminous cord function
F 18	Additional light function
F 19	Automatic closing time
F 21	Preflashing time
F 22	Working time
F 25	Courtesy light time
F 28	Adjusting opening speed
F 29	Adjusting closing speed
F 30	Adjusting opening slow-down speed
F 31	Adjusting closing slow-down speed
F 33	Adjusting calibration speed
F 34	Sensitivity during movement
F 35	Sensitivity during slow-down
F 37	Adjusting the opening slow-down starting point
F 38	Adjusting the closing slow-down starting point
F 49	Enabling serial connections
F 50	Saving data in memory roll
F 51	Reading memory roll data
F 52	Copying parameters from Master to Slave
F 56	Number of the peripheral
F 60	Sleep Mode function
F 61	Pre-flashing function
F 63	Changing COM speed
U 1	Type of command to associate to a user via radio control
U 2	Deleting single users
U 3	Deleting all users
A 1	Boom-type setting
A 2	Motor test
A 3	Calibrating boom travel
A 4	Resetting parameters
A 5	counting the number of maneuvers
H 1	Software version

Functions menu



IMPORTANT! Start programming by first performing the following: A1 BOOM-TYPE SETTING, A2 MOTOR TEST, F1 TOTAL STOP and A3 CALIBRATING BOOM TRAVEL.

F1	Total stop [1-2]	0 = Deactivated (default) / 1 = Activated
NC input - boom stop while excluding any automatic stop; to resume movement, use a control device. Connect the safety device to 1-2.		
F2	Input [2-CX]	0 = Deactivated (default) / 1 = C1 / 4 = C4 / 5 = C5 / 9 = C9
NC Input - For associating: C1 = reopening during closing for photocells, C4 = obstruction wait, C5 = immediate closing, C9 = immediate closing with obstruction wait when closing.		
F3	Input [2-CY]	0 = Deactivated (default) / 1 = C1 / 4 = C4 / 5 = C5 / 9 = C9
NC Input - For associating: C1 = reopening during closing for photocells, C4 = obstruction wait, C5 = immediate closing, C9 = immediate closing with obstruction wait when closing.		

F5	Safety test	0 = Deactivated (default) / 1 = CX / 2 = CY / 3 = CX+CY
After every opening or closing command, the board will check whether the photocells are working properly.		
F6	Maintained action	0 = Deactivated (default) / 1 = Activated
The barrier opens and closes by keeping one button pressed. Opening button on 2-3 and closing button on 2-4. When this function is activated, all other control devices, even radio ones, are excluded.		
F9	Obstruction detection with motor idle	0 = Deactivated (default) / 1 = Activated
With the barrier closed, open or after a total stop, the operator stays still if the safety devices (photocells and sensitive edges) detect an obstruction.		
F10	Warning light	0 = lit with boom raised and moving (default) / 1 = flashes intermittently each half second when opening when closing it flashes intermittently every second permanently lit with the boom raised off with the boom lowered
It warns of the barrier status. The light bulb is connected to 10-5.		
F11	Excluding the encoder	0 = encoder activated (default) / 1 = encoder deactivated
It excludes controlling slow downs, obstruction detection and sensitivity.		
F14	Sensor type selection	0 = transponder sensor or magnetic card reader command 1 = control with keypad selector (default)
Setting the type of sensor for controlling the barrier.		
F 15	Luminous cord intermittance	0 = Moving boom (default) / 1 = Moving and closed boom
It warns of the status of the barrier with intermittent lights.		
F18	Additional light	0 = Flashing light(default) / 1 = Cycle / 2 = Courtesy
Output on [10-E1]. The flashing light works when opening and closing. The cycle lamp stay on from the moment in which the barrier starts opening until it closes completely (including the automatic closing time). In case the automatic closing in not inserted, it stays on only during the movement. The courtesy light stays on for a fixed 180 seconds or it can be adjusted, see function F 25.		
F19	Automatic closing time	0 = Deactivated (default) / 1 = 1 s / 2 = 2 s / ... / 180 = 180 s
The first automatic-closing wait starts when the opening endstop point is reached and can be set to between 1 and 180 seconds. The automatic closing does not activate is any of the safety devices trigger when an obstruction is detected, after a total stop or during a power outage.		
F21	Preflashing time	0 = Deactivated (default) / 1 = 1 s / ... / 5 = 5 s
After an opening or closing command, the flashing light connected to 10-E1, flashes from 1 to 10 seconds before the maneuver starts.		
F22	Working time	5 = 5 s / / 120 = 120 s (default)
Gearmotor working time during opening and closing. The working time can be adjusted between 5 and 120 seconds.		
F25	Courtesy light time	5 = 5 s / / 120 = 120 s (default).
Supplementary light, that stays lit during the barrier's opening and closing movement. The time may be adjusted between 5 and 120 seconds		
F28	Opening maneuver speed	70 = Minimum speed / ... / 100 = Maximum speed.
Setting the boom's opening speed, calculated as a percentage. ⚠ Warning: the speed parameter fields vary depending on the type of boom: - for jointed booms, of 2 m and 4 m, set the speed percentage to between 70 and 100; - for booms of 6 m and 8 m, set the speed percentage to between 80 and 100.		
F 29	Closing maneuver speed	70 = Minimum speed / ... / 100 = Maximum speed.
Setting the boom's closing speed, calculated as a percentage. ⚠ Warning: the speed parameter fields vary depending on the type of boom: - for jointed booms, of 2 m and 4 m, set the speed percentage to between 70 and 100; - for booms of 6 m and 8 m, set the speed percentage to between 80 and 100.		

F 30	Opening slow-down speed	15 = Minimum speed / ... / 40 = Maximum speed
Setting the boom's opening slow-down speed, calculated as a percentage. ⚠ Warning: the speed parameter fields vary depending on the type of boom: - for jointed booms of 2 m, set the slow-down speed percentage to between 20 and 40; - for booms of 4 m, set the slow-down speed percentage to between 20 and 30; - for booms of 6 m and 8 m, set the slow-down speed percentage to between 15 and 40.		
F31	Closing slow-down speed	15 = Minimum speed / ... / 40 = Maximum speed
Setting the boom's closing slow-down speed, calculated as a percentage. ⚠ Warning: the speed parameter fields vary depending on the type of boom: - for jointed booms and for 2-meter ones, set the slow-down speed percentage between 20 and 40;- for 4-meter booms, set the slow-down speed percentage between 20 and 30. - for booms of 6 m, set the slow-down speed percentage to between 15 and 30; - for booms of 8 m, set the slow-down speed percentage to between 15 and 20;		
F33	Calibration speed	20 = 20% of the travel (minimum) / ... / 40 = 40% of the travel (maximum)
Setting the boom's travel automatic calibration, calculated as a percentage		
F34	Boom travel sensitivity	10 = maximum sensitivity / ... / 100 = minimum sensitivity (default)
Adjusting obstruction detection sensitivity during boom travel.		
F35	Slow-down sensitivity	10 = maximum sensitivity / ... / 100 = minimum sensitivity (default)
Adjusting obstruction detection sensitivity during slow-down.		
F37	Opening slow-down point	40 = 40% of the travel / ... / 60 = 60% travel
Percentage adjustment of the boom's total travel, from the beginning of the opening slow-down point. Warning! The percentage varies depending on the boom type: - for jointed booms of 2 m and 4 m, set the percentage to between 40 and 60; - for booms of 6 m and 8 m, set the percentage to between 60 and 70.		
F38	Closing slow-down point	20 = 20% of the travel / ... / 75 = 75% of the travel
Establishing the total travel percentage, from the beginning of the closing slow-down point. Warning! The percentage varies depending on the boom type: - for jointed booms and 2-meter booms, set the speed percentage to between 20 and 40; - for 2 m booms, set the percentage to between 40 and 60; - for 6 m booms, set the percentage to between 60 and 70; - for 8 m booms, set the percentage to between 65 and 75;		
F 49	Enabling serial connections	0 = Deactivated (default) / 1 = Paired / 2 = Alternate / 3 = CRP
For enabling the paired or alternate function or the CRP home automation connection system .		
F50	Save data	0 = Deactivated (default) / 1 = Activated
To save system users and settings in memory roll. 📖 This function only appears if the memory roll has been fitted into the control panel.		
F51	Read data	0 = Deactivated (default) / 1 = Activated
To upload the data saved in the memory roll into the control panel. 📖 This function only appears if the memory roll has been fitted into the control panel.		
F52	Passing settings in paired/alternating mode	0 = Deactivated (default) / 1 = Activated
Loading parameters of the MASTER barrier into the SLAVE barrier. 📖 This function appears only if function F 49 is set to either PAIRED or ALTERNATE.		
F56	Peripheral number	1 ----> 225
With systems fitted with several operators and the CRP (Came Remote Protocol) system connection, set an address between 1 and 225 for each control panel.		
F60	Sleep Mode	
To reduce the amount of energy consumed by the stand-by photocells.		
F61	Pre-flashing	0 = when opening and closing (default) / 1 = only when closing / 2 = only when opening
After an opening or closing command, the flashing light connected to 10-E1m flashes before starting the maneuver. For setting the time, see function F 21.		
F63	Change COM speed	0=1200 Baud / 1=2400 / 2=4800 / 3=9600 / 4=14400 / 5=19200 / 6=38400 / 7=57600 / 8=115200 B
Setting the communication speed used in the CRP (Came Remote Protocol) connection system.		

U 1 Entering a user	1 = Step-step command (open-close) / 2 = Sequential command (open-stop-close-stop) / 3 = Open only command / 4 = Partial command / 5 = contact B1-B2 output
Up to a maximum of 25 users can be entered and each can be associated to a function of choice among those available. Entering is done via transmitter or other control device (see ENTERING USERS AND ASSOCIATED COMMANDS).	
U 2 Deleting a user	
To delete a user (see DELETING SINGLE USERS paragraph)	
U 3 Deleting users	0 = Deactivated / 1 = Deleting all users
To delete all user.	
A 1 Setting the boom type	0 = Jointed boom / 2 = Boom 2 m / 4 = Boom 4 m / 6 = Boom 6 m / 8 = Boom m
To establish the boom type. △ The choice of boom type limits certain speed, slow-down and calibration limits. This is to safeguard the entire barrier.	
A 2 Motor test	0 = Disable / 1 = Activate
To verify the boom's proper rotating direction (see MOTOR TEST paragraph)	
A 3 Calibrating boom travel	0 = Disable / 1 = Activate
Automatic boom travel calibration (see CALIBRATING BOOM TRAVEL paragraph).	
A 4 Resetting parameters	0 = Disable / 1 = Activate
Warning! If need be, the default parameters can be restored. The default settings are restored and the travel calibration deleted. Restoring default settings and cancelling boom travel calibration operation.	
A 5 Counting maneuvers	
Show the number of completed maneuvers (--- = 0 maneuvers; 1 = 1,000 maneuvers; 100 = 100,000 maneuvers; 999 = 999,000).	
H 1 Version	
View the software version.	

Motor test

1. Select A 2. Press ENTER to confirm.

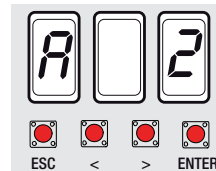

2. Select 1 to activate test. Press ENTER to confirm...

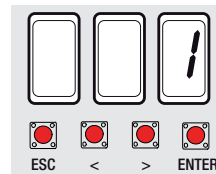

3. ... the dashes (---) will appear while waiting for the command.

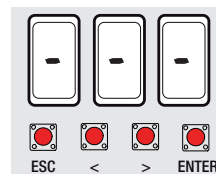

4. Keep pressed the < key and check whether the barrier opens.

📖 If the barrier closes, invert the motor phases (M with N).

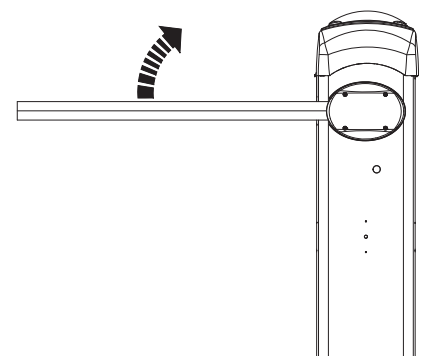
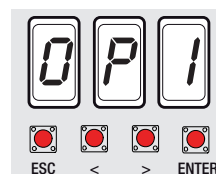

Travel calibration

 Before doing a travel calibration, establish the boom type, check that the boom is balanced and that the maneuvering area is free of obstructions.

Important! While calibrating, all of the safety devices will be disabled excluding the TOTAL STOP one.

1. Select A 3.
Press ENTER to confirm.

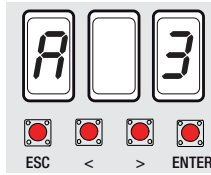

2. Select 1 and press ENTER to confirm that the barrier has calibrated itself automatically.

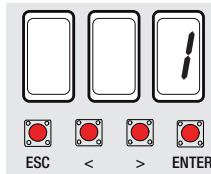

3. The operator will perform a closing maneuver until the endstop point...

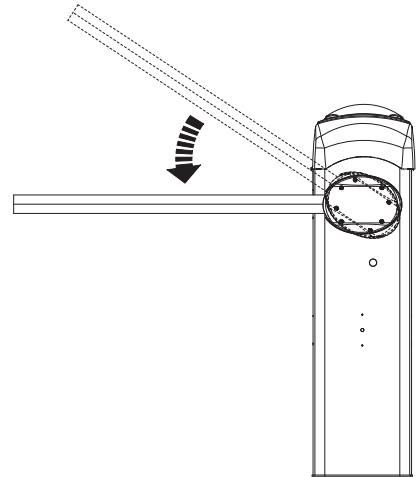
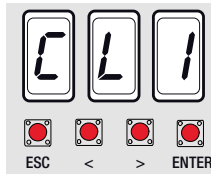

4. ... then, the barrier will perform an opening maneuver until the endstop point.

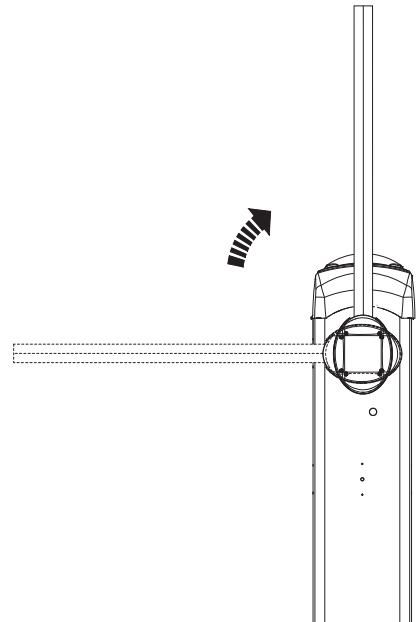
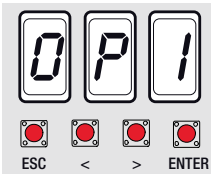

When entering/deleting users, the flashing numbers that appear, are numbers that can be used for other users you may wish to enter (maximum 25 users).

Entering a user with an associated command

1. Select U 1.
Press ENTER to confirm.

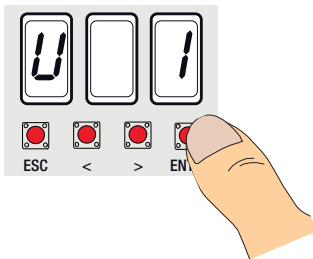

2. Select a command to associate to the user.
The commands are:

- step-step (open-close) = 1;
- open = 3;
- partial opening/pedestrian = 4.

The partial/pedestrian command appears only if function F 49 is activated.
Press ENTER to confirm...

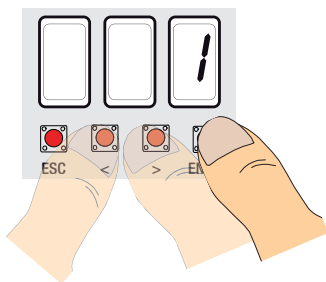

3. ... an available number between 1 and 25 will flash for a few seconds. This number is then assigned to the user after having sent the code with the transmitter or other control device (sensor, card reader or keypad selector).

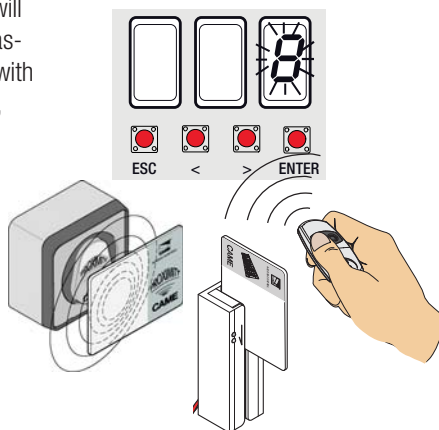

User	Associated command
1 -	
2 -	
3 -	
4 -	
5 -	
6 -	
7 -	
8 -	
9 -	
10 -	
11 -	
12 -	
13 -	
14 -	
15 -	
16 -	
17 -	
18 -	
19 -	
20 -	
21 -	
22 -	
23 -	
24 -	
25 -	

Deleting a single user

1. Select U 2.
Press ENTER to confirm.

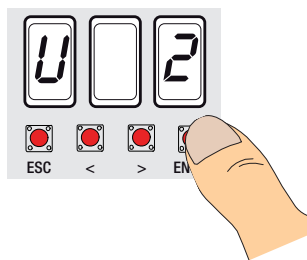

2. Select the user number to delete by using the arrow keys. Press ENTER to confirm...

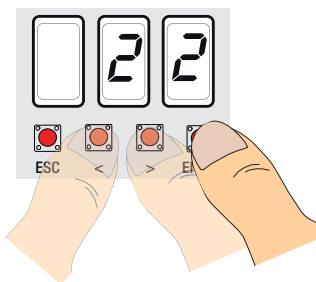

3. ...the abbreviation CLR will appear to confirm the user has been deleted.

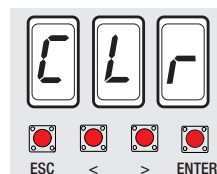

Memory Roll Card

To memorize user data and configure the system, to then reuse them with another control board even on another system.

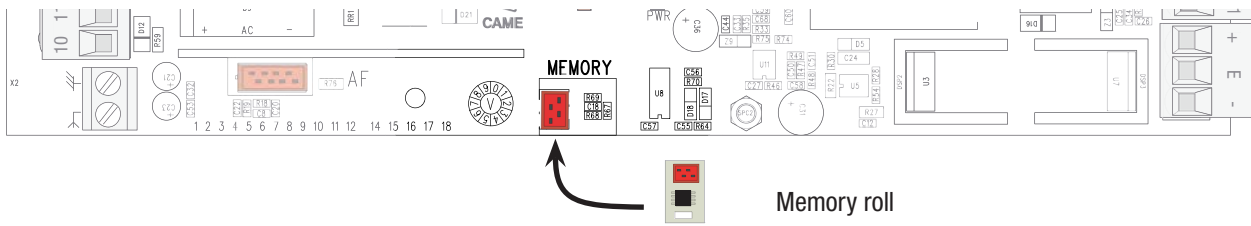

FINAL OPERATIONS

When you done with the electrical connections and setting up, fit the control panel cover and fasten it with the screws ❶. Replace the inspection hatch and upper dome ❷. Lock the hatch with the key ❸.

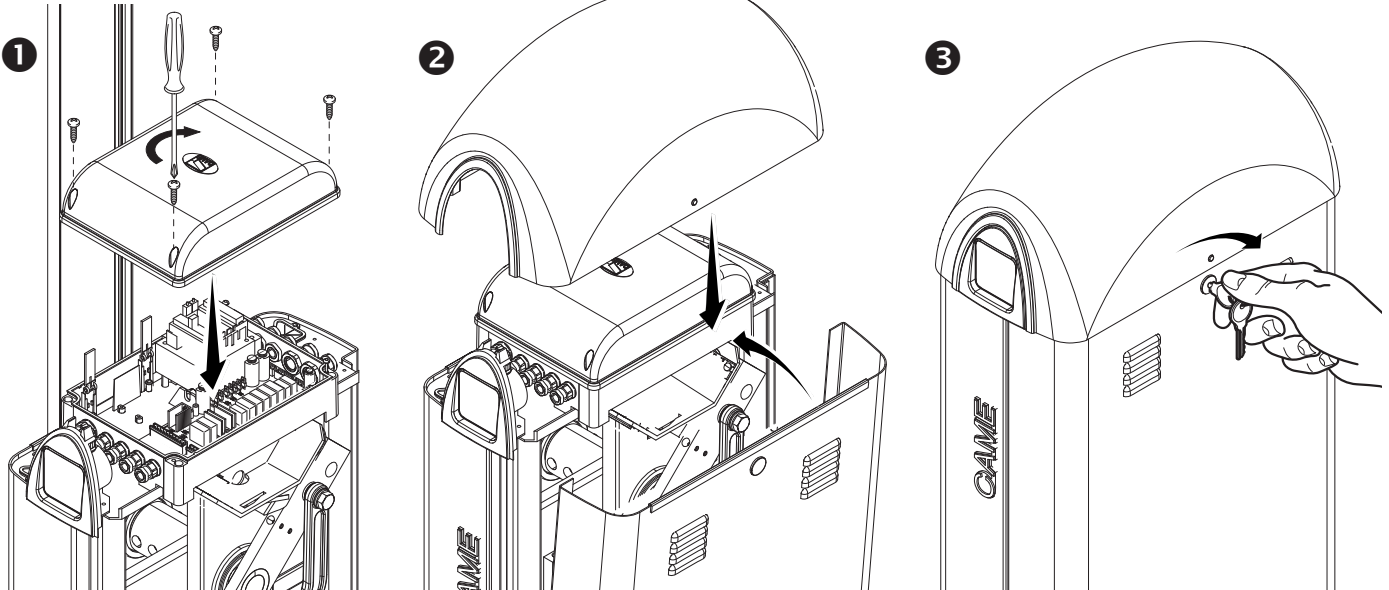

RELEASING THE BOOM

⚠ This procedure must be done with the main power cut off.

Fit the key into the lock and turn it clockwise ❶. Manually lift the boom and lock it again by turning the key counter clockwise ❷.

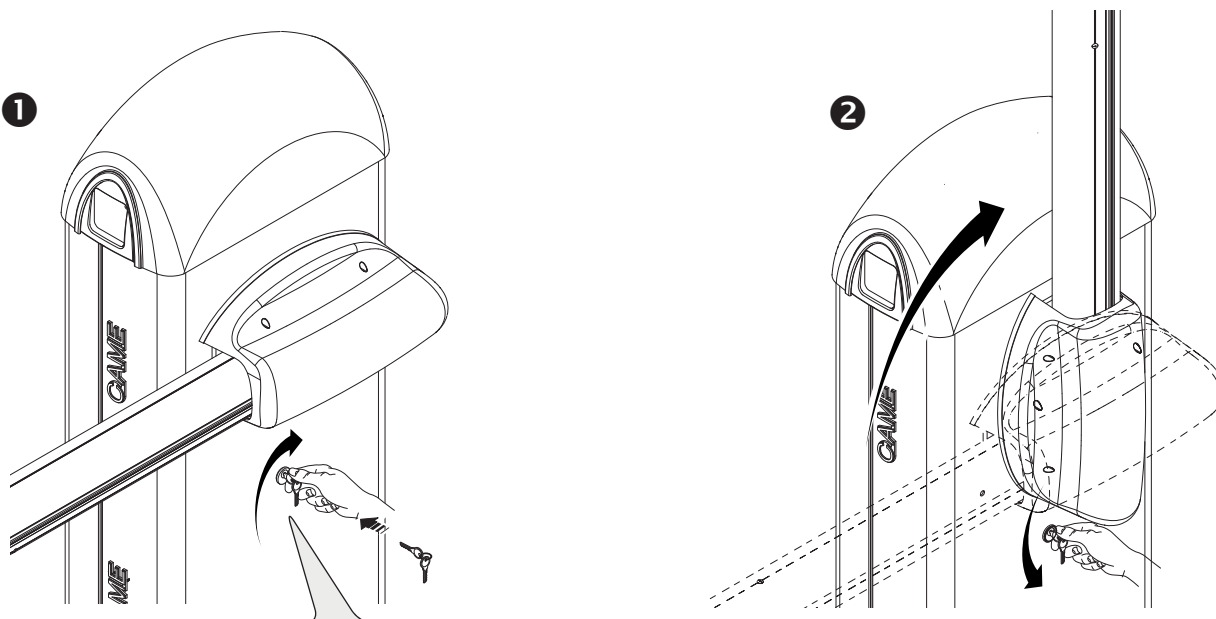

⚠ **WARNING!** This operation is potentially hazardous for user, when for whatever reason, such as the boom being badly fastened, ripped out or broken during an accident, and so on, the loosened springs no longer provide the proper balancing action. This could lead to a sudden rotation of the boom attachment and/or of the boom itself.

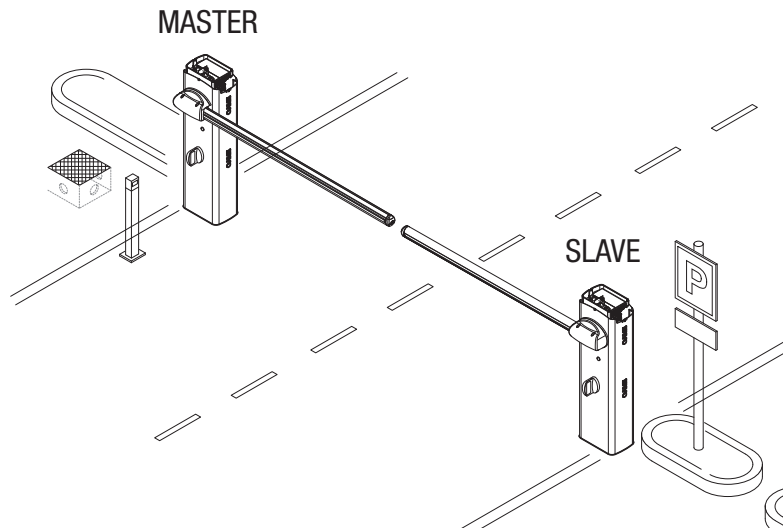

Important! Before making any electrical connections and programming, do the following on both barriers:

- setting the boom type;
- motor test;
- calibrating the boom travel.

Fit the RSE card (with DIP switches sent to OFF) onto the control panel connector of both barriers.

Connect the two control panels via a CAT 5 type-cable (max 1,000 m) to terminals A-A / B-B / GND-GND, see paragraph on CONNECTING WITH THE CAME REMOTE PROTOCOL (CRP) AND FOR PAIRED OR ALTERNATE OPERATING MODE. Connect all of the control and safety devices to the MASTER control panel.

Important! Deactivate function F 19 (automatic closing time) on the SLAVE barrier's control panel.

Configuring the MASTER barrier

Select function F 49. Press ENTER to confirm.

Select 1 (paired) and press ENTER.

Carry out any settings and adjustments on the MASTER control panel.

Transferring parameters from MASTER to SLAVE

Select function F 52 on the MASTER control panel.

Select 1 and press ENTER.

Operating modes

- 1 STEP-STEP or OPEN ONLY command. Both booms open.
- 2 PARTIAL OPENING/PEDESTRIAN command. Only the MASTER barrier opens.

For the types of command that can be selected and paired to users, see the ENTERING USERS WITH ASSOCIATED COMMANDS

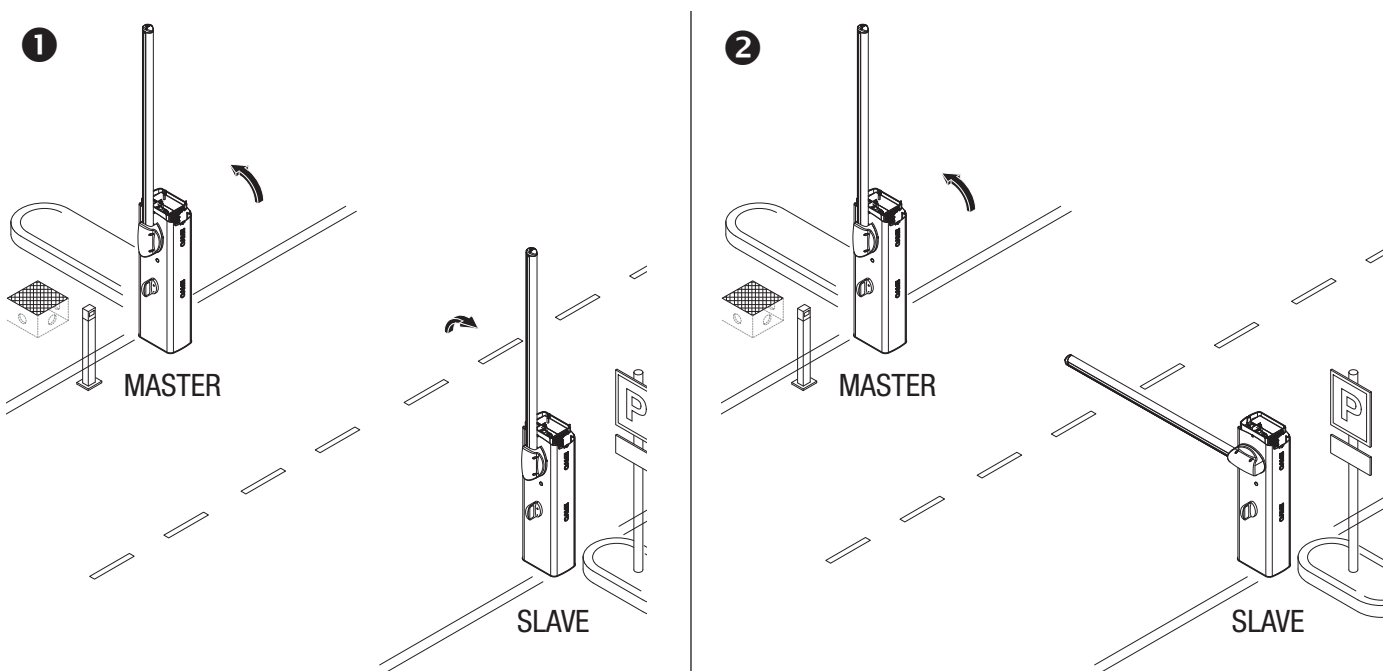

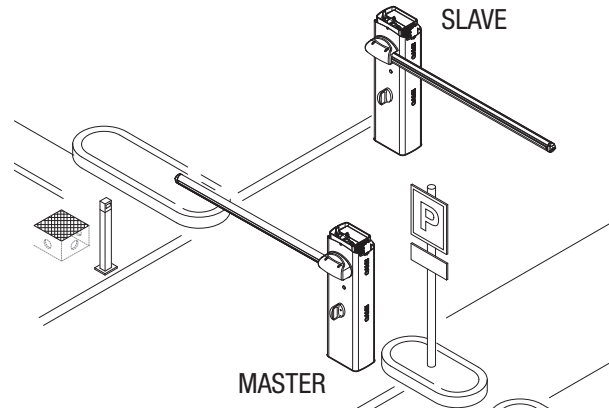

Important! Before making any electrical connections and programming, do the following on both barriers:

- setting the boom type;
- motor test;
- calibrating the boom travel.

Fit the RSE card (with DIP switches sent to OFF) onto the control panel connector of both barriers.

Connect the two control panels via a CAT 5 type-cable (max 1,000 m) to terminals A-A / B-B / GND-GND, see paragraph on CONNECTING WITH THE CAME REMOTE PROTOCOL (CRP) AND FOR PAIRED OR ALTERNATE OPERATING MODE.

Connect all of the control and safety devices to the MASTER control panel.

Important! Deactivate function F 19 (automatic closing time) on the SLAVE barrier's control panel.

Configuring the MASTER barrier

Select function F 49. Press ENTER to confirm.

Select 2 (alternate) and press ENTER.

Carry out any settings and adjustments on the MASTER control panel.

Transferring parameters from MASTER to SLAVE

Select function F 52 on the MASTER control panel.

Select 1 and press ENTER.

Operating modes

- 1 ONLY OPEN (contact 2-3) command. For opening MASTER barrier boom.
 - 2 PARTIAL/PEDESTRIAN OPENING (contact 2-3P) command. For opening the SLAVE barrier boom.
 - 3 STEP-STEP (contact 2-7) command. Both booms open. This is an emergency opening command, to free the passage.
- For the types of command that can be selected and paired to users, see the ENTERING USERS WITH ASSOCIATED COMMANDS

MASTER BARRIER

Send the ONLY OPEN command (contact 2-3) from a transmitter or other control device, to open the boom of the MASTER barrier.

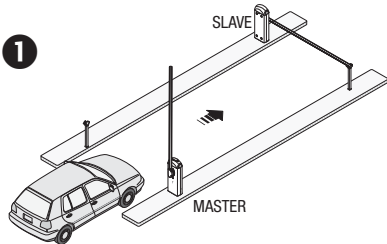

Approach the SLAVE barrier. It will automatically open only after the MASTER barrier automatically closes. The automatic closing of the MASTER barrier is excluded in the event that the safety devices detect an obstruction (such as when a car has yet to clear the MASTER barrier).

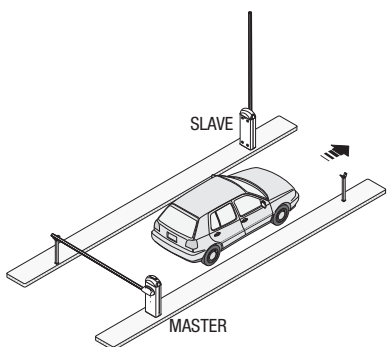

SLAVE BARRIER

Send the PARTIAL/PEDESTRIAN OPENING command (contact 2-3P) from a transmitter or other control device, to open the boom on the SLAVE barrier.

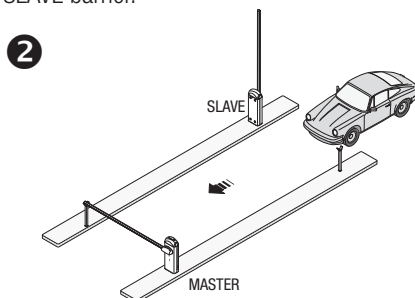

Approach the MASTER barrier. It will automatically open only after the SALVE barrier automatically closes. The automatic closing of the SLAVE barrier is excluded in the event that the safety devices detect an obstruction (such as when a car has yet to clear the SLAVE barrier).

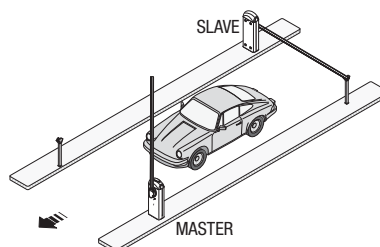

EMERGENCY OPENING

Send the STEP-STEP (contact 2-7) command from a transmitter or other control device, to simultaneously open the booms of the MASTER and SLAVE barrier.

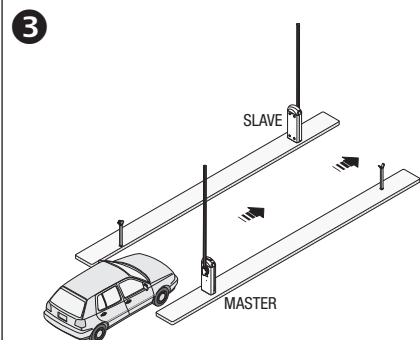

ERROR MESSAGE

 The error messages appear on display and are notified by LEDs.

Er1	The boom travel calibration was interrupted by the activation of the STOP button.
Er3	Encoder is broken.
Er4	Services test error.
Er5	Insufficient working time
Er6	Maximum number of obstructions detected.
Er7	Transformer overheating.
Er8	The inspection hatch is open.
C0	Contact 1-2 (NC) is open.
C1, C4, C5 or C9	The (NC) contacts are open.
The warning LED flashes	The control board is not yet calibrated for the boom travel.

TROUBLESHOOTING

PROBLEM	REFERENCE	CHECK
The boom neither opens nor closes	1-2-3-4-6-8-13-18	1 - Lock the inspection hatch with the key
The boom opens but does not close	4-7	2 - Deactivate the MAINTAINED ACTION function
The boom closes but does not open	4-7-12-13	3 - Check the power supply and fuses
The barrier does not perform automatic closing	11-12-13	4 - The NC contacts are open
The barrier does not work with the transmitter	2-14-16	6 - Deactivate the MASTER-SLAVE function
The boom's direction of travel is inverted	7-18	7 - Check the boom's balancing and spring tautness
Only one transmitter works	22	8 - Deactivate the OBSTRUCTION DETECTION function
The photocells do not work	12-23-24	11 - Activate the AUTOMATIC CLOSING function
The warning LED flashes quickly	4	12 - Check the proper direction of travel
The warning LED stays lit	13	13 - Check the control devices
The boom does not reach the endstop	7	14 - Replace the AF card
The boom cannot be balanced	7-15	15 - Check the length ration between boom and applied accessories
The barrier does not slow down	7-15	16 - Memorize the radio code again
The barrier does not work with emergency batteries	8-25-26	18 - Adjust the sensitivity
The boom starts slow	7	22 - Enter or duplicate the same code on all transmitters
		23 - Activate the photocells
		24 - Connect the photocells serially instead of in parallel fashion
		25 - Check the batteries
		26 - Respect the photocell's power supply polarities

Extraordinary maintenance

△ The following table is for logging any extraordinary maintenance jobs, repairs and improvements performed by specialized contractors.

📖 Any extraordinary maintenance jobs must be done only by specialized technicians.

Extraordinary maintenance log

Fitter's stamp	Name of operator
	Job performed on (date)
	Technician's signature
	Requester's signature
Job performed _____ _____	

Fitter's stamp	Name of operator
	Job performed on (date)
	Technician's signature
	Requester's signature
Job performed _____ _____	

Fitter's stamp	Name of operator
	Job performed on (date)
	Technician's signature
	Requester's signature
Job performed _____ _____	

DISMANTLING AND DISPOSAL

👉 CAME CANCELLI AUTOMATICI S.p.A. employs a certified Environmental Management System at its premises, compliant with the UNI EN ISO 14001 standard to ensure the environment is safeguarded.

Please continue safeguarding the environment. At CAME we consider it one of the fundamentals of our operating and market strategies. Simply follow these brief disposal guidelines:

♻️ DISPOSING OF THE PACKAGING

The packaging materials (cardboard, plastic, and so on) should be disposed of as solid urban waste, and simply separated from other waste for recycling.

Always make sure you comply with local laws before dismantling and disposing of the product.

DO NOT DISPOSE OF IN NATURE!

♻️ DISMANTLING AND DISPOSAL

Our products are made with different materials. Most of these (aluminum, plastic, iron, electrical cables) is classified as solid urban waste. They can be recycled by separating them before dumping at authorized city dumps.

Whereas other components (control boards, batteries, transmitters, and so on) may contain hazardous pollutants.

These must therefore be disposed of by authorized, certified professional services.

Before disposing, it is always advisable to check with the specific laws that apply in your area.

DO NOT DISPOSE OF IN NATURE!

DECLARATION OF CONFORMITY

Declaration CE - Came Cancelli Automatici S.p.A. declares that this device conforms to the essential, pertinent requirements provided by directives 2006/42/CE and 2004/108/CE.

An original copy of the declaration of conformity is available on request.



ENGLISH - Manual code: **119GJ05EN** v. 1 11/2014 © CAME Cancelli Automatici S.p.A. - The data and information in this manual may be changed at any time and without notice.

- IT** • Per ogni ulteriore informazione su azienda, prodotti e assistenza nella vostra lingua:
- EN** • For any further information on company, products and assistance in your language:
- FR** • Pour toute autre information sur la société, les produits et l'assistance dans votre langue :
- DE** • Weitere Infos über Unternehmen, Produkte und Kundendienst in Ihrer Sprache bei:
- ES** • Para cualquier información sobre la empresa, los productos y asistencia en su idioma:
- NL** • Voor meer informatie over het bedrijf, de producten en hulp in uw eigen taal:
- PT** • Para toda e qualquer informação acerca da empresa, de produtos e assistência técnica, em sua língua:
- PL** • Wszystkie inne informacje dotyczące firmy, produktów oraz usług i pomocy technicznej w Waszym języku znajdują się na stronie:
- RU** • Для получения дополнительной информации о компании, продукции и сервисной поддержке на вашем языке:
- HU** • A vállalatra, termékeire és a műszaki szervizre vonatkozó minden további információért az Ön nyelvén:
- HR** • Za sve dodatne informacije o poduzeću, proizvodima i tehničkoj podršci na vašem jeziku:
- UK** • Для отримання будь-якої іншої інформації про компанію, продукцію та технічну підтримку:



www.came.com

CAME
safety & comfort



parkare

CAME S.p.a.

Via Martiri Della Libertà, 15
31030 **Dossone di Casier** (TV)

☎ (+39) 0422 4940

✉ (+39) 0422 4941

Assistenza Tecnica/Numero Verde 800 295830