

# 746 Compact Slide Gate Operator: Installation Manual

## Contents

Important Safety Information.....	2
Technical Data .....	4
Unpacking the Operator .....	5
The 746 Compact Slide Gate Operator .....	6
General Characteristics .....	6
Operating Logic .....	7
Manual Release Mechanism.....	7
Installation Instructions.....	9
Setting the Forms for the Concrete Mounting Slab.....	9
Mounting the Operator on the Concrete Slab.....	9
Chain Operator.....	9
Rack and Pinion Operator .....	10
Connecting the Electrical Power.....	11
Set the DIP Switches.....	13
Setting Up the Limit Switches .....	14
Adjusting the Clutch Torque.....	15
Finishing the Installation.....	16
Troubleshooting .....	17
Exploded View, 746 Parts.....	19

**FAAC International, Inc.**  
**303 Lexington Avenue**  
**Cheyenne, WY 82007**  
www.faacusa.com

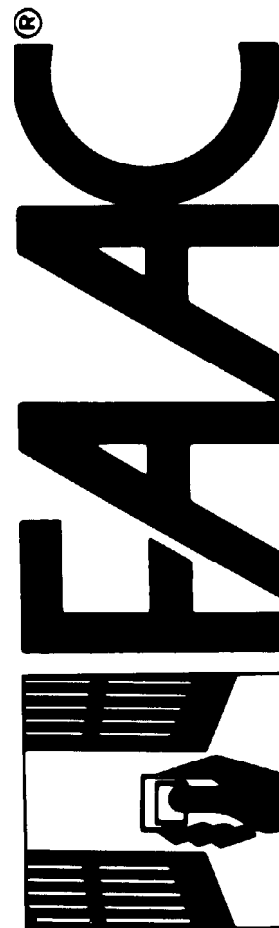

# Important Safety Information

Both the installer and the owner and/or operator of this system need to read and understand this installation manual and the safety instructions supplied with other components of the gate system. This information should be retained by the owner and/or operator of the gate.

---

**WARNING!** To reduce the risk of injury or death

1. **READ AND FOLLOW ALL INSTRUCTIONS.**
  2. Never let children operate or play with gate controls. Keep the remote control away from children.
  3. Always keep people and objects away from the gate. **NO ONE SHOULD CROSS THE PATH OF THE MOVING GATE.**
  4. Test the gate operator monthly. The gate **MUST** reverse on contact with a rigid object or stop when an object activates the non-contact sensors. After adjusting the force or the limit of travel, retest the gate operator. Failure to adjust and retest the gate operator properly can increase the risk of injury or death.
  5. Use the emergency release only when the gate is not moving.
  6. **KEEP GATES PROPERLY MAINTAINED.** Read the owner's manual. Have a qualified service person make repairs to gate hardware.
  7. The entrance is for vehicles only. Pedestrians must use separate entrance.
  8. **SAVE THESE INSTRUCTIONS.**
- 

There are three kinds of safety issues involved with an automatic gate operator: issues arising from the design of the gate, from the installation of the gate and the operator, and from the use of the gate operator. The following information is designed to help you be sure your gate and its operator are well-designed, installed

correctly, and used safely.

## Gate Design

1. A gate is a potential traffic hazard, so it is important that you locate the gate far enough away from the road to eliminate the potential of traffic getting backed up. This distance is affected by the size of the gate, how often it is used, and how fast the gate operates.
2. The operator you choose to install on your gate must be designed for the type and size of your gate and for the frequency with which you use the operator.
3. Your gate must be properly installed and must work freely in both directions before the automatic operator is installed.
4. An automatic operator should be installed on the inside of the property/fence line. Do not install the operator on the public side of the property/fence line.
5. Pedestrians should not use a vehicular gate system. Prevent such inappropriate use by installing separate gates for pedestrians.
6. Exposed, reachable pinch points on a gate are potentially hazardous and must be eliminated or guarded.
7. Outward swinging gates with automatic operators should not open into a public area.
8. The operating controls for an automatic gate must be secured to prevent the unauthorized use of those controls.
9. The controls for an automatic gate should be located far enough from the gate so that a user cannot accidentally touch the gate when operating the controls.
10. An automatic gate operator should not be installed on a gate if people can reach or extend their arms or legs through the gate. Such gates should be guarded or screened to prevent such access.

## Installation

1. If you have any question about the safety of the gate operating system, do not install this operator. Consult the operator manufacturer.
2. The condition of the gate structure itself directly affects the reliability and safety of the gate operator.
3. Only qualified personnel should install this

equipment. Failure to meet this requirement could cause severe injury and/or death, for which the manufacturer cannot be held responsible.

4. The installer must provide a main power switch that meets all applicable safety regulations.
5. Clearly indicate on the gate with a minimum of 2 warning signs (visible from either side of the gate) that indicate the following:
  - The gate is automatic and could move at any time, posing a serious risk of entrapment.
  - Children should not be allowed to operate the gate or play in the gate area.
  - The gate should be operated only when it is visible to the operator and the when the area is free of people and obstructions.
6. It is extremely unsafe to compensate for a damaged gate by overtightening a clutch or increasing hydraulic pressure.
7. Devices such as reversing edges and photocells must be installed to provide better protection for personal property and pedestrians. Install reversing devices that are appropriate to the gate design and gate application.
8. Before applying electrical power, be sure that the voltage requirements of the equipment correspond to your supply voltage. Refer to the label on your operator system.

### Use

1. Use this equipment only in the capacity for which it was designed. Any use other than that stated should be considered improper and therefore dangerous.
2. When using any electrical equipment, observe some fundamental rules:
  - Do not touch the equipment with damp or humid hands or feet.
  - Do not install or operate the equipment with bare feet.
  - Do not allow small children or incapable persons to use the equipment.
3. If a gate system component malfunctions, turn off the main power before making any attempt to repair it.
4. Do not attempt to impede the movement of the gate. You may injure yourself as a result.
5. This equipment may reach high temperatures during operation; therefore, use caution when touching the external housing of the operator.
6. Learn to use the manual release mechanism according to the procedures found in this installation manual.
7. Before carrying out any cleaning or maintenance operations, disconnect the equipment from the electrical supply.
8. To guarantee the efficiency of this equipment, the manufacturer recommends that qualified personnel periodically check and maintain the equipment.

U.L. Class and FAAC Operator Model		Duty Cycle	Typical Use
<b>Class I: Residential Vehicular Gate Operator</b>			
402	746	Limited duty	<ul style="list-style-type: none"> <li>• Home use</li> <li>• Small apartment building, for example, up to 4 units in a building, with limited public access</li> </ul>
422	750		
412	760		
630			
<b>Class II: Commercial/General Access Vehicular Gate Operator</b>			
400	640	Continuous duty	<ul style="list-style-type: none"> <li>• Apartment buildings</li> <li>• Very public access</li> </ul>
620			
<b>Class III: Industrial/Limited Access Vehicular Gate Operator</b>			
400	640	Continuous duty	<ul style="list-style-type: none"> <li>• No public access</li> </ul>
620			
<b>Class IV: Restricted Access Vehicular Gate Operator</b>			
620	640	Continuous duty	<ul style="list-style-type: none"> <li>• Prison rated security</li> </ul>

## Technical Data

Physical dimensions of the operator case	Length: 7 3/4 in. (195 mm) Width: 5 1/2 in. (140 mm) Height: 11 3/8 in. (290 mm)
Power voltage required*	230 VAC, +6 or -10%, 60 Hz*
Built-in control panel	746 MPS, 220 VAC ±10%, 50–60 Hz
Absorbed power	300 Watts
Amperage draw	1.5 amps
Horsepower rating	1/2 hp
Speed of motor rotation	1400 rpm
Gear ratio	30:1
Operating temperature range	-13 to 158 deg F (-25 to +70 deg C)
Thermal cut out of motor	248 deg F (120 deg C)
Weight, including oil	31 lb (14 kg)
Oil quantity	2.2 qt (2.1 liters)
Oil type	FAAC XD 220 or Shell/Tellus #15
Gate speed	10 in./sec (25.4 cm/sec)
Maximum motor run time**	120 sec
Pulling force***	35 lb (16 kg)
Duty cycles/hour	Depends on gate size but the maximum motor run time is 50% at 72 deg F (22 deg C)
Maximum amperage draw for accessories	360 mA

\* Your standard 220 VAC power source meets the specification for 230 VAC, +6 or -10%.

\*\* If the motor completes its maximum run time, you will have to reset the control panel for normal operation.

\*\*\* The maximum weight pulled at start up assumes nominal voltage (220 VAC) at 72 deg F (22 deg C) and assumes the use of high-quality, lubricated bearing rollers on a level V track.

### Control Panel

You must install the 746 MPS control panel with the 746 Operator. The control panel allows you to set the following operational controls:

- Logic: E1, E2, A1, or A2
- Pause time: 5, 10, 30, or 120 sec
- 5-sec preflashing of attached warning light

In addition, the control panel allows you to easily define the direction of the gate's opening direction for the limit switch and allows you to control the force of the gate's movement.

**Power supply:** 220 VAC

**Operating logic:** E1, E2, A1, or A2

# Unpacking the Operator

Complete the following steps to unpack the operator.

1. Before you remove the operator from the carton, check for any physical shipping damage, such as a torn shipping carton or leaking oil. Inspect the operator carefully after removing it from the carton. Notify the carrier immediately if you note any damage because the carrier must witness the damage before you can file a claim.
2. As you unpack the operator, insure that all parts are included. The package should contain all the items listed in the Parts List for your particular operator.
3. Remove the vent screw from the operator before applying power (see Fig. 1). Be sure to save the vent screw for possible future use because the screw should be installed if you transport the operator.  
**Caution:** The vent screw *must* be removed before you start the operator.
4. Remove the top cover of the operator using a 3-mm Allen wrench. Remove and discard the special Styrofoam block resting on the transformer in the center of the control panel (see Fig. 12 for the transformer location on the control panel).
5. Remove the oil plug (see Fig. 1) with a 17-mm wrench and check for the proper oil level. The oil should be just slightly above the silver armature plate, located below the copper motor windings as viewed through the oil filler hole.
6. At this time remove the rubber cover from the Manual Release mechanism protruding from the side of the operator (see Fig. 1). Keep track of the rubber cover because you will replace it at the end of the installation process if you are not using a locking cap.

You are now ready to begin the actual installation of the operator (see page 9).

## Parts List for the Chain Operator

- 1 746 operator (equipped with chain drive mechanism); the cover is attached with 2 (of 4) 3-mm Allen-head bolts; mounting brackets are attached
- 1 746 foundation plate (optional; this part must be ordered separately)
- 1 Z20 sprocket
- 1 Hardware package that contains the following:
  - 1 5 mm bolt with flat washer

- 1 Manual Release lever
- 2 Limit switch plates, each is 2-1/8 × 3-1/2 in. (54 × 89 mm)
- 4 Rubber weather plugs for top cover hold down bolts
- 1 Top cover gasket
- 2 3-mm Allen-head bolts
- 1 Chain mounting kit with the following:
  - 2 Chain tension adjustment bolts, each with 3 nuts and 1 locking washer
  - 2 Chain tension adjustment bolt mounting brackets with 4 clamps
- 1 Idler assembly kit with the following:
  - 1 Chain guard with 1 bolt and flat washer for mounting
  - 1 Idler mounting bracket with 5 longer mounting bolts and 1 mounting stud for the chain guard
  - 2 Idler sprockets with 2 snap rings for mounting
  - 2 Rack limit switch plates with 4 mounting bolts and lock washers
  - 2 (Optional) Bolt-on operator mounting brackets with 4 bolts, 4 washers, 4 lock washers, and 4 nuts

## Parts List for the Rack and Pinion Operator

- 1 746 operator (equipped with rack and pinion drive mechanism); cover is attached with 2 (of 4) 3-mm Allen-head bolts; mounting brackets are attached
- 1 746 foundation plate (optional; this part must be ordered separately)
- 1 Z20 pinion
- 1 Hardware package that contains the following:
  - 1 Manual Release lever
  - 2 Limit switch plates, each measures 2-1/8 × 3-1/2 in. (54 × 89 mm)
  - 4 Rubber weather plugs for top cover hold down bolts
  - 1 Top cover gasket
  - 2 3-mm Allen-head bolts

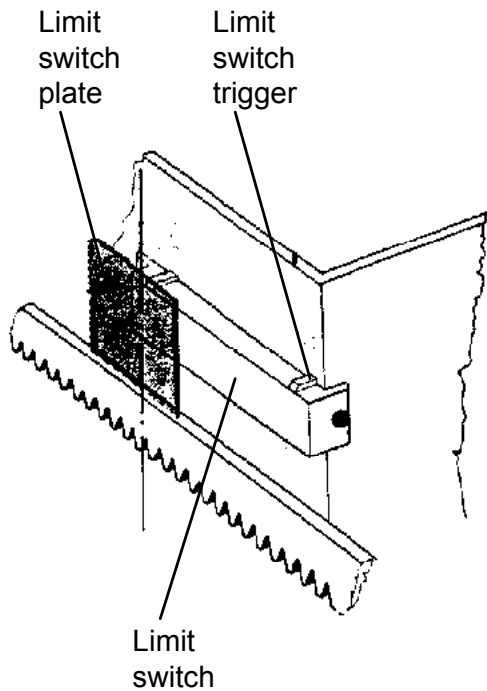

- 1 Inductive limit switch
- 2 Manual Release assembly (old style; see Fig. 2 for new style)
- 3 Mounting brackets
- 4 Pinion
- 5 Vent screw
- 6 Oil plug
- 7 746 MPS control panel
- 8 Clutch adjustment screw

**Caution:** The vent screw *must* be removed before you start the operator!

**Figure 1. The main components of the 746 operator**

## The 746 Compact Slide Gate Operator

### General Characteristics

The FAAC 746 Compact Slide Gate Operator uses **GentleSlide™ Motion Management** to slide gates with a pulling force of up to 35 lb (16 kg).

This operator is available in two basic versions, the rack and pinion or the chain version. It comes as a package containing the drive unit and factory-wired electronic control panel inside the top cover of the unit. All external reversing devices and other accessories must be ordered separately.

The advanced design of the operator features a small, self-contained unit composed of an electric motor with a built-in clutch and a reduction gear box, both housed in a die-cast aluminum casing. The rack or chain is driven by the motor to slide the gate.

The FAAC 746 MPS microprocessor control panel is used with the FAAC 746 Slide Gate Operator. The control panel operates the slide gate according to the DIP

switch settings you make for the following:

- Operating logic (choose 1 of 4)
- Pause time (5 sec to 2 min)
- 5-sec preflashing of an attached warning light

The control panel provides power for gate accessories of 24 VDC (pulsed or constant). The maximum recommended amperage draw for accessories should not exceed 360 milliamps.

An adjustable friction clutch is located on the input side of the gear box so that when torque exceeds a preset value, the drive torque on the output shaft remains at a constant level.

The 746 operator is also equipped with an electronic speed sensor control device that is designed to help provide anti-crush protection.

**WARNING!** The anti-crush feature should not be considered adequate safety protection for pedestrians or property! Other additional reversing accessories, such as photocells and reversing edges, must be installed.

If the electronic speed sensor detects any slowing down of the gate while it is opening, caused by any form of obstacle in the gate's opening path, the operator stops. The gate can then be closed by sending another input signal. If the electronic speed sensor detects any slowing down of the gate during its closing phase, the gate automatically re-opens.

The electric motor, two-disc clutch, and reduction gear are completely immersed in a special oil that lubricates the moving parts and also dissipates heat generated while the unit is operating. The heat is further dissipated through the outer casing of black anodized aluminum.

The holding power of the gear mechanism ensures that the gate stays perfectly shut. There is no need to fit an additional lock on the gate.

The Manual Release mechanism is a key- and lever-operated device that allows you to open or close the gate by hand whenever the need arises. The Manual Release mechanism is useful, for example, when the electrical power goes out and you want to open or close the gate.

A limit switch assembly stops the drive motor when the limit switch plates mounted on the gate are sensed. The limit switch is inductive and watertight to increase its reliability and functionality.

The adjustable electronic braking system insures that the gate stops exactly where and when required.

Two die-cast flanges surround the pinion to prevent foreign objects from being inserted between the rack and pinion either accidentally or intentionally. A guard around the sprockets on the chain version of the 746 Operator provides comparable safety.

## Operating Logic

The 746 MPS control panel provides the following operating logics (see page 8 for more detail):

**E1 and E2** The two semi-automatic operating logics are designed for users who want to signal the gate to open, stop, and close. The two modes differ in the way triggered reversing devices affect gate behavior during closing.

**A1 and A2** The two automatic operating logics are designed for users who want to signal the gate to open and then automatically close after a preset pause time. The two modes differ in the way triggered reversing devices affect gate behavior during closing and while the gate is pausing before it closes.

## Manual Release Mechanism

The Manual Release mechanism is used during installation or when no electrical power is available.

To use the Manual Release mechanism (see Figure 2), lift the lock cover and insert the key. Then rotate the key in the clockwise direction and pull the Manual Release lever out as shown in Figure 2. This disengages the operator motor from the pinion or chain sprocket.

Now you have to move the gate by hand to open it or close it. Also, the gear reduction of the final drive is deactivated, so the gate will not lock in a closed position.

To re-engage the operator motor for normal operation, close the Manual Release lever, turn the key counterclockwise and remove it, and shut the lock cover. Push the gate leaf an inch or two in either direction to re-engage the operator. You should feel the operator re-engage.

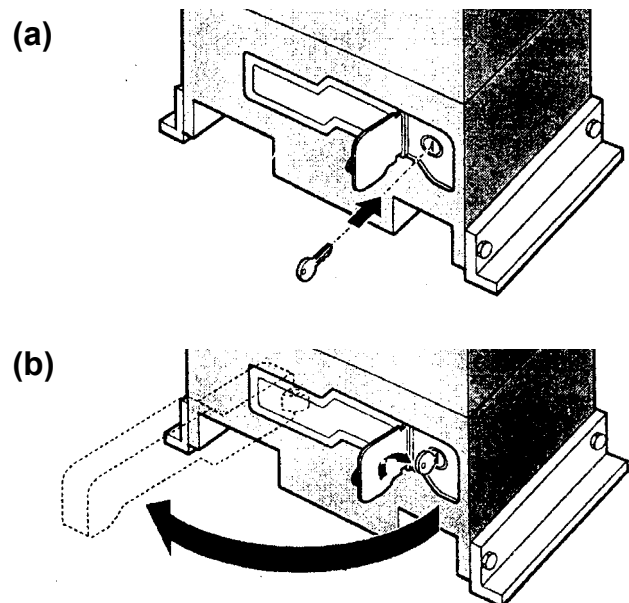

**Figure 2.** To use the Manual Release lever, (a) lift the lock cover and insert the key; (b) then turn the key clockwise and pull out the Manual Release lever as shown.

**Logic E1**

Gate Status	Signal		
	Open	Stop	Reversing
Closed	Opens*	no effect	no effect
Opening	Stops	Stops	no effect
Opened	Closes*	no effect	no effect
Closing	Reverses*	Stops	Reverses*
Stopped	Closes. Opens if reversing device is triggered*	no effect	no effect

**Logic A1**  
(This logic mode makes the best use of reversing devices.)

Gate Status	Signal		
	Open	Stop	Reversing
Closed	Opens and then closes after timed pause	no effect	no effect
Opening	no effect	Stops	no effect
Opened	Closes after 5 sec pause*	Pause count is disabled	Pause count is interrupted until reversing device is no longer triggered*
Closing	Reverses	Stops	Reverses
Stopped	Closes. Opens* if reversing device is triggered.	no effect	no effect

**Logic E2**

Gate Status	Signal		
	Open	Stop	Reversing
Closed	Opens*	no effect	no effect
Opening	Stops	Stops	no effect
Opened	Closes*	no effect	no effect
Closing	Reverses*	Stops	Stops. Reverses* when reversing device no longer triggered.
Stopped	Closes. Opens* if reversing device is triggered.	no effect	no effect

**Logic A2**

Gate Status	Signal		
	Open	Stop	Reversing
Closed	Opens and then closes after pause time	no effect	no effect
Opening	no effect	Stops	no effect
Opened	Closes after 5 sec*	Pause count is disabled	Pause count is canceled. Closes 5 sec after reversing device is no longer triggered.
Closing	Reverses	Stops	Stops. Opens when reversing device is no longer triggered.
Stopped	Closes. Opens* if reversing device is triggered.	no effect	no effect

\* If preflashing is selected, gate movement is delayed for an additional 5 seconds.

 Marks the responses in gate behavior that differ from the companion operating logic above or below



# Installation Instructions

## Setting the Forms for the Concrete Mounting Slab

You need to lay out the concrete forms (see Fig. 3) so that the top surface is level with the top of the bottom frame member of the gate. The depth of the concrete slab should be at least 18 in. (457 mm) below ground level or just below the frost line, whichever is greater. (Your soil conditions will also determine the size of the concrete footing.)

Locate the electrical conduits (one for high- and one for low-voltage lines) in the concrete forms so that they protrude from the top approximately 1/2 in. (13 mm). The conduits should be placed 6-1/4 in. (160 mm) from the right edge of the foundation plate (facing the operator and gate) and 4-1/2 in. (114 mm) from the inside edge to line up with the hole in the foundation plate.

After the concrete is poured in the forms and before it has a chance to set, insert the foundation plate into the cement and position it flush with the top of the concrete and aligned with the top of the lower gate frame. Allow the concrete to set for a minimum of two days prior to installing the operator.

## Mounting the Operator on the Concrete Slab

Follow the instructions below that apply to the version of the operator you are installing.

## Chain Operator

First decide whether you want to use the mounting brackets attached to the operator. The attached mounting brackets require you to weld the brackets to the foundation plate.

Two optional mounting brackets allow you to bolt the operator to the mounting plate. If you would rather bolt the operator to the foundation plate, remove the attached mounting brackets, retain the paper gasket, and bolt on the optional brass mounting brackets.

As shown in Figure 4, place the operator on the foundation plate with the sprocket facing the gate and with approximately 1-3/8 in. (35 mm) between the inside edge of the gate frame and the center of the drive sprocket.

While placing the operator on the foundation plate, thread the electrical wiring through the conduit in the operator as shown in Figure 5.

Secure the gate chain brackets to the vertical front and back posts of the gate leaf using the U bolts provided. Set the height of the gate chain brackets so that the center of each idler sprocket (located on either side of the drive sprocket) is slightly higher than the center line of the brackets. This alignment will compensate for any sag in the chain.

Place the chain over the top of the idler sprockets and under the drive sprocket (see Fig. 6).

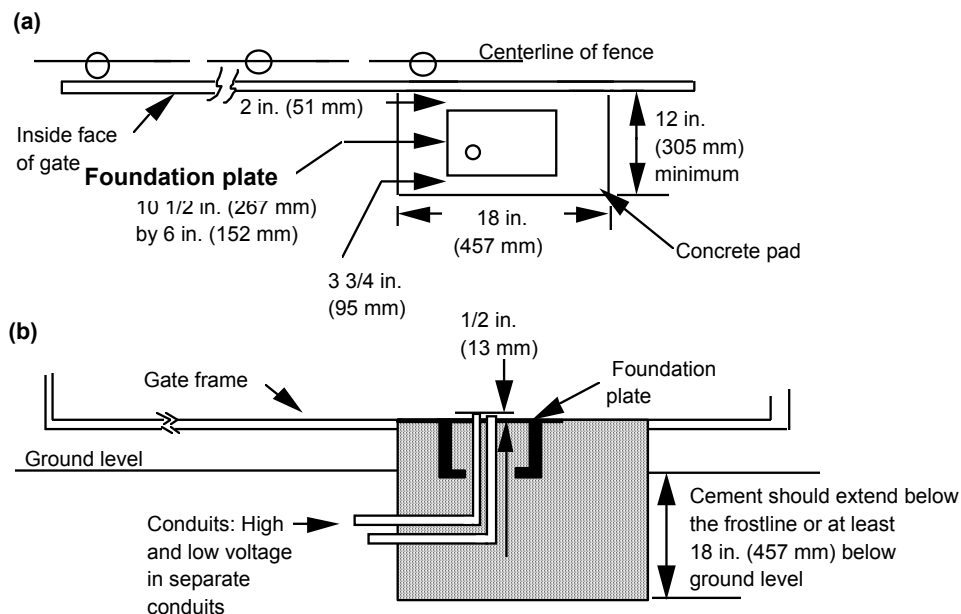

Figure 3. Concrete mounting slab: (a) top view and (b) side view

## Rack and Pinion Operator

**Mounting the Pinion:** As shown in Figure 7, place the operator on the foundation plate with the pinion facing the gate and with approximately 1-3/8 in. (35 mm) between the inside edge of the gate frame and the center of the drive pinion.

While placing the operator on the foundation plate, thread the electrical wiring through the conduit in the operator as shown in Figure 5.

Fit one 1/16-in. (1.5 mm) thick sheet-metal shim under each mounting bracket in order to keep the operator slightly raised. These shims are setting the height of the rack and will be removed later to provide operating clearance between the rack and the pinion. Spot weld the factory-fitted mounting brackets to the foundation plate as shown in Figure 8. (You will remove these spot welds later, so do not over weld.)

**Installing the Rack:** Manually disengage the operator motor with the Manual Release (see Fig. 2) and open the gate by hand as far as possible. Fit the spacers, washers and bolts on the rack sections as shown in Figure 9. The bolts should be centered in the slots of

the rack sections.

With the gate in the fully open position, lay a section of rack on the pinion. Engage the teeth and make sure that the end of the rack is even with the end of the gate and that the rack is level. Spot weld the spacer that is nearest the pinion to the gate.

Pull the gate toward the closed position until the pinion is directly under the spacer on the opposite end of the rack section and spot weld that spacer. Next you can spot weld the center spacer.

Now place another rack section end next to the end of the rack just installed. Be sure that the two sections are aligned and level and that the teeth match perfectly. Use another piece of rack, upside down, to check and set the alignment of the teeth as shown in Figure 10.

Repeat the process of spot welding the spacers of this rack section as you did on the first section. Continue this process for each section of rack.

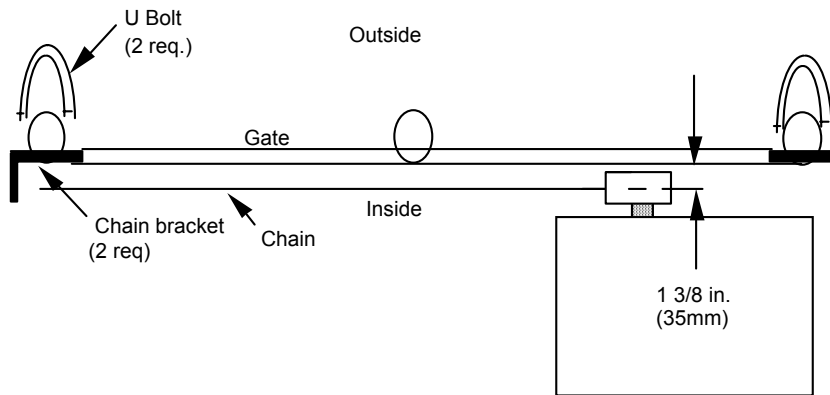

Figure 4. Mounting the chain operator, top view

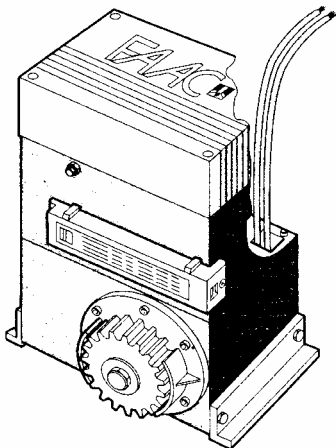

Figure 5. Thread the electrical wiring up

through the operator in the conduit provided

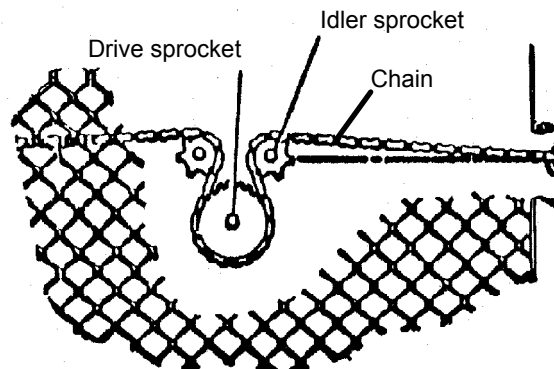

Figure 6. How to install the chain around the sprockets

**Final Welding:** After spot welding all rack sections, move the gate from the fully closed to the fully open position several times. Make sure that the rack runs smoothly along the center of the pinion. If the rack and pinion operate smoothly, finish welding the spacers to the gate.

Again, ensure smooth gate movement and then securely tighten the rack mounting bolts in the spacers.

Remove the spot welds and shims from under the mounting brackets. Secure the operator to the foundation plate by welding the operator mounting brackets to the plate.

## Connecting the Electrical Power

**WARNING!** Turn the main power off before you make any electrical connections or set any switches on the control panel.

The installer is responsible for providing a power cable (with ground protected by a circuit breaker) from the main 220 VAC power source to the operator (see Fig. 11). All wiring should conform to applicable electrical codes, and all wiring and fittings should be weatherproof and/or suitable for burial.

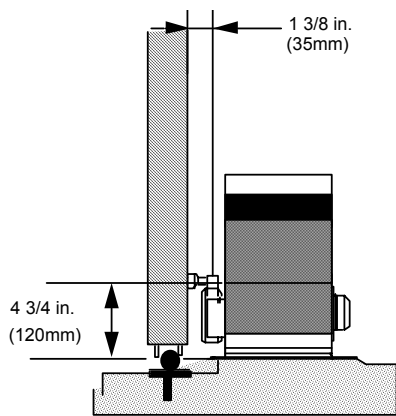

**Figure 7. Mounting the rack and pinion operator**

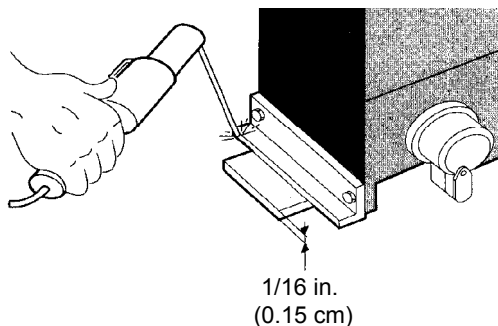

**Figure 8. Spot weld the mounting brackets to the foundation plate**

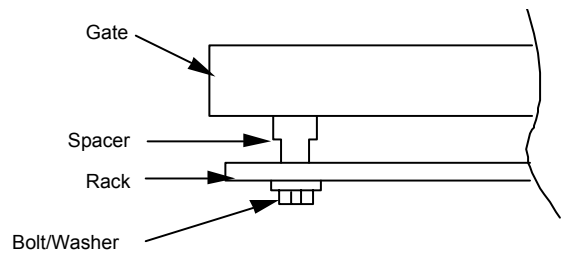

**Figure 9. Installing the rack, top view**

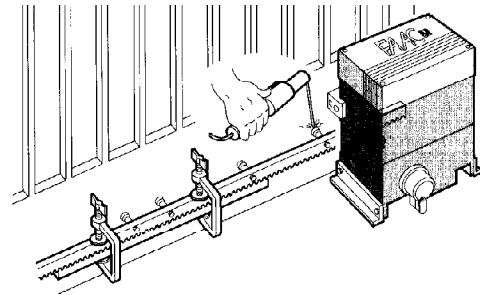

**Figure 10. Use an upside down piece of rack to align the rack before welding**

**Caution:** The operator is grounded only by the grounded circuit the installer provides.

Connecting the electrical power to the operator consists of simply connecting the 220-V power source to the 746 MPS control panel. The motor and capacitor have been connected to the control panel terminal blocks by the factory.

Connect the main 220-VAC input power to the terminals labeled L and N (see Fig. 12 and 13) on terminal block J7. Do not turn on the main power yet.

Connect all reversing devices in series to terminals 4 and 1. To operate, they must be normally closed. If no reversing devices are installed, then you must install a jumper between terminals 4 and 1 for the operator to work properly.

Connect all stop devices in series to terminals 1 and 3. To operate, they must be normally closed. If no stop device is installed, then you must install a jumper between terminals 1 and 3 for the operator to work properly.

Connect all activating (input signal) devices in parallel to terminals 1 and 2 (you *must* install at least one activating device). Each device must be normally open to activate the gate. An activating device momentarily closes the switch to activate the operator.

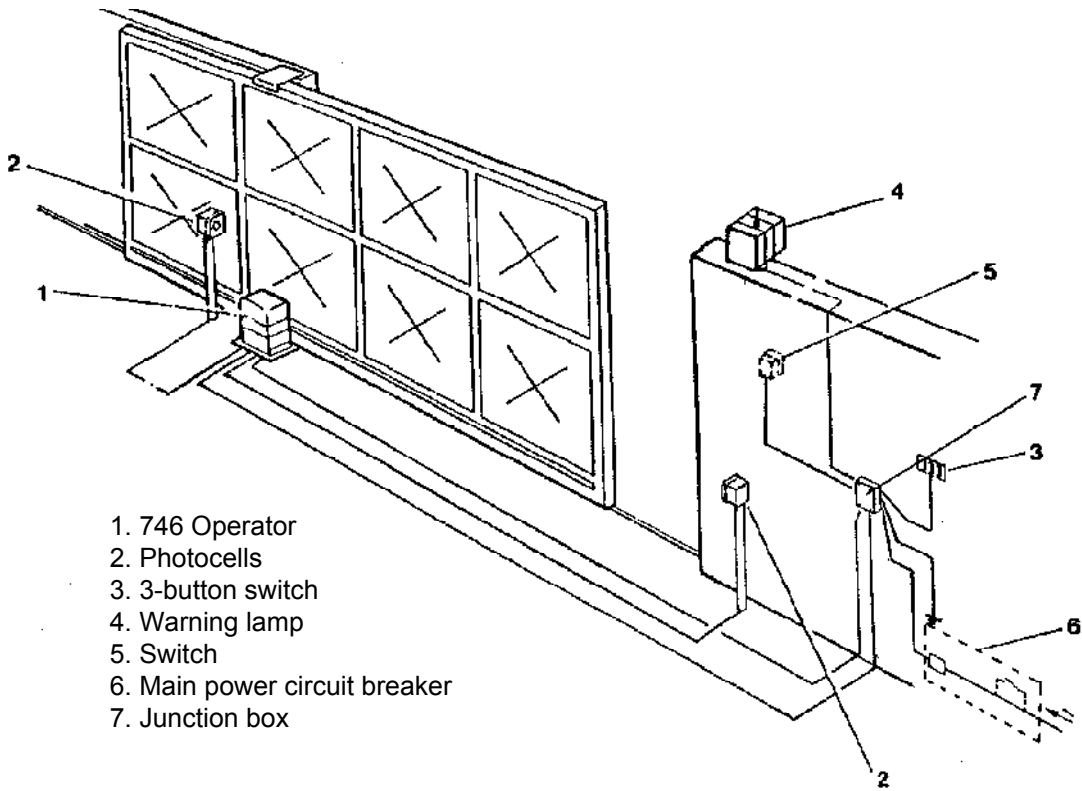

- 1. 746 Operator
- 2. Photocells
- 3. 3-button switch
- 4. Warning lamp
- 5. Switch
- 6. Main power circuit breaker
- 7. Junction box

Figure 11. The gate layout for the 746 Operator

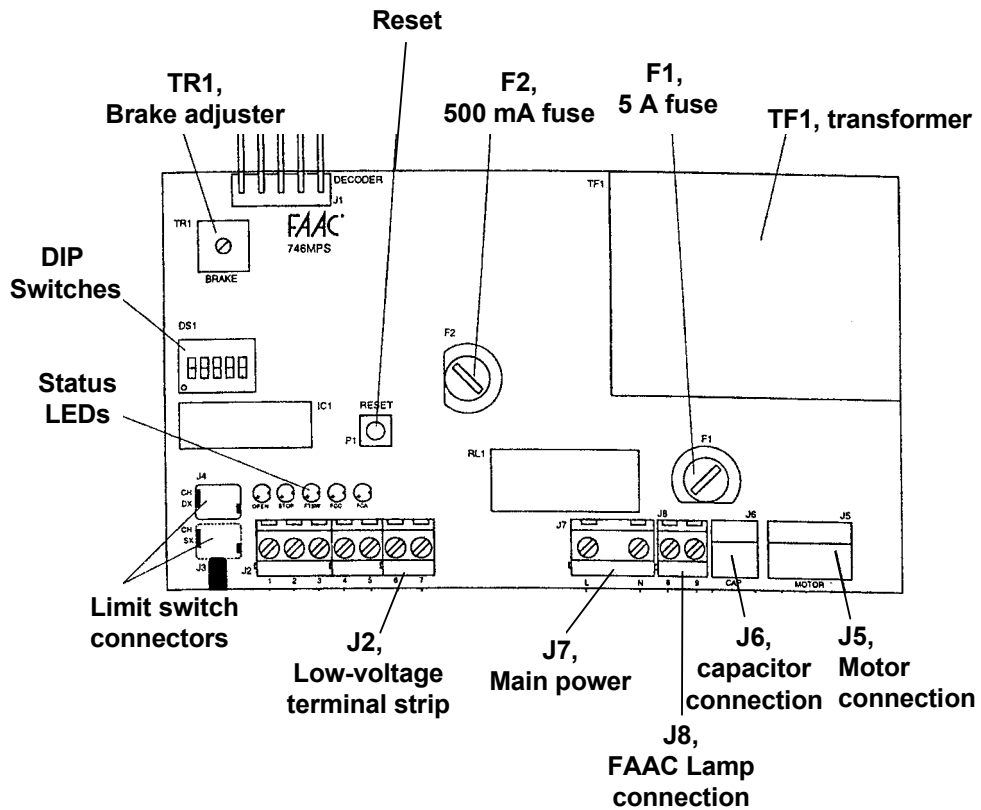

Figure 12. The 746 MPS control panel

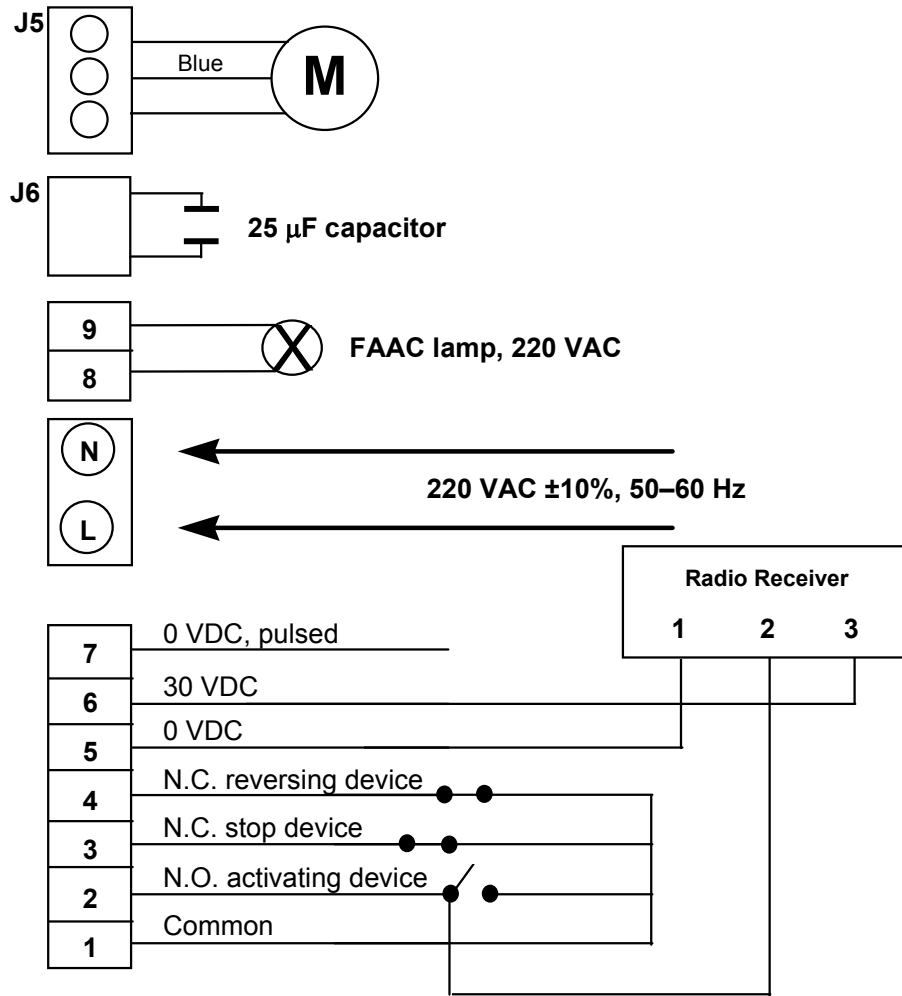

Figure 13. The wiring diagram for the 746 MPS control panel

## Set the DIP Switches

**WARNING!** Turn the main power off before you make any electrical connections or set any DIP switches on the control panel.

You need to set five DIP switches for the proper operation of your gate site. After you set the switches be sure to turn on the power and then press the reset button on the control panel so that the settings you have made take effect.

**Note:** DIP switch 6 is not used on the 746 MPS control panel.

Set DIP switches 1 and 2 for logic, switches 3 and 4 for pause time, and switch 5 for warning light function as shown in the following tables.

**Note:** Be sure to press the Reset button after you have made your DIP switch settings.

### Logic Settings

Logic	DIP Switch	
	1	2
E1	On	On
E2	On	Off
A1	Off	On
A2	Off	Off

### Pause Time Settings

Pause Time	DIP Switch	
	3	4
5 sec	On	On
10 sec	Off	On
30 sec	On	Off
120 sec	Off	Off

### Settings for Warning Light Preflashing Function

5-sec Preflashing	DIP Switch 5
Preflashing	On
No preflashing	Off

## Setting Up the Limit Switches

**WARNING!** Turn the main power off before you make any electrical connections or set any switches on the control panel.

The maximum travel of the gate when it opens and closes is controlled by inductive limit switches. These limit switches are controlled by the wiring of blocks J3 and J4 on the control panel (see Fig. 12).

Figure 14 shows you how to connect the limit switch ribbon cable. Where you plug in the cable—into either block J3 or block J4—depends on the configuration of your gate. Be sure the cable is well seated in its receptacle.

The pair of limit switch plates furnished with the operator activate the limit switch. For the rack and pinion drive, the limit switch plates are fixed on the top of the rack at either end of the gate leaf (see Figure 15). In the case of the chain drive, they are fixed to each end of the chain on the gate leaf (see Figure 16). For either drive, the distance between the plates and the limit switch located on the gate side of the 746 Operator should be 3/16 in. (5 mm).

The limit switch plates should be positioned on the rack or chain to enter the magnetic field of the limit switch when the gate is still about 2 in. (50 mm) from the fully opened or fully closed position. The 2-in. (50-mm) distance prevents abrupt braking and avoids over stressing the entire gate mechanism.

Do the following to mount the limit switch plates.

First disengage the operator's motor with the Manual Release and then fully open the gate by hand. Then be sure the cover is removed from the operator so that you can see the status light-emitting diodes (LEDs) on the 746 MPS control panel (see Fig. 12).

Between the gate leaf and the operator, hold one plate in your hand just above the rack or chain on the driveway end of the gate leaf and within 3/16 in. (5 mm) of the limit switch. Move the limit switch plate in your hand in the direction of gate's opening travel.

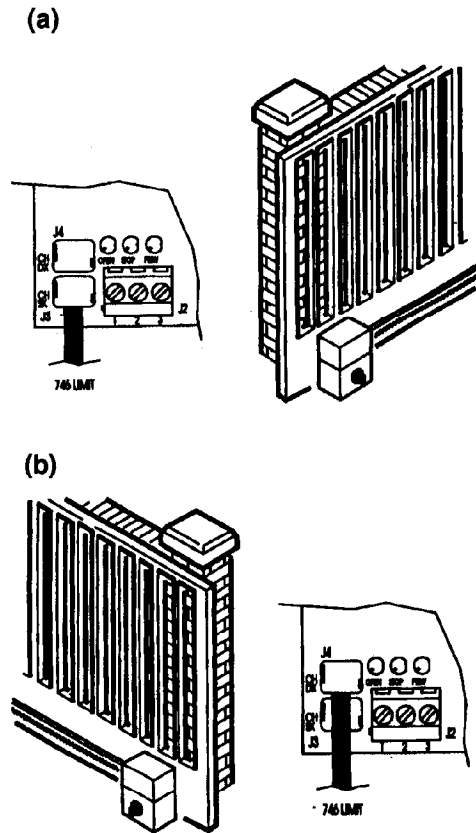

**Figure 14.** The electrical wiring of the limit switches on the 746 MPS control panel: (a) connect the cable to J3 or (b) connect the cable to J4

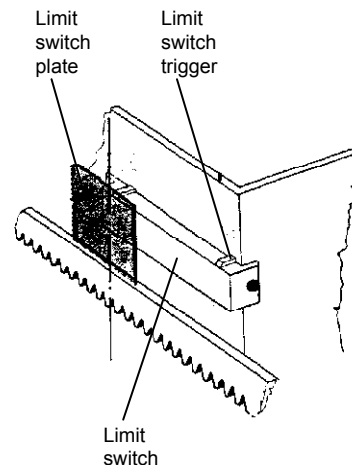

**Figure 15.** The limit switch assembly on a rack and pinion installation

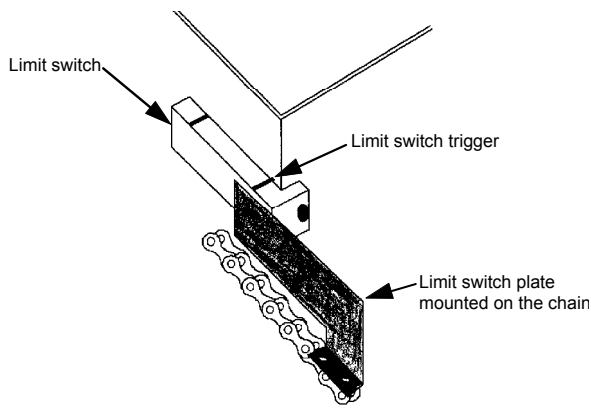

**Figure 16. Limit switch assembly on a chain installation**

Watch the status LEDs. The point where the FCA LED on the control panel goes out is the triggering point of the limit switch. You need to continue moving the limit switch plate 1-3/4 in. (45 mm) farther in the gate's opening direction in order to allow for braking distance. Spot-weld or mount the limit switch plate in this position to test the mounting.

Repeat this same procedure for the limit switch for the gate's closing travel using the other end of the gate leaf. Put the gate in the closed position and use the FCC LED as the trigger indicator. Note that each limit switch plate must be located 1-3/4 in. (45 mm) in advance of the limit switch trigger point to allow for smooth braking.

To check whether the limit switches are correctly positioned, disengage the motor with the Manual Release lever and select the E operating mode by setting both DIP switches 1 and 2 to *on*.

Then to test the mountings of the limit switch plates, turn on the power and generate an input signal. The motor will turn in the opening direction but the gate will not move because the motor is disengaged. The motor will run (for about 2 minutes) until the control panel senses the limit switch plate in your test.

**Note:** If the motor completes its maximum motor run time before you test a limit switch, you will have to reset the control panel. To reset, either press the Reset button on the 746 MPS control panel, or cycle the main power off and then on. The operator will then run normally.

Move the gate by hand in the opening direction and listen to the motor as the limit switch plate moves by the limit switch. The motor should turn off when the gate is 2 in. from the fully opened position.

Run the same sort of test of the limit switch plate mounting for the closing direction. If necessary, adjust the position of either limit switch plate and test the new mounting by manually moving the gate.

If the limit switches are functioning properly when you manually operate the gate, engage the motor of the 746 Operator with the Manual Release lever and signal the gate to operate in the opening and closing directions. If it operates properly, weld the limit switches into place.

## Adjusting the Clutch Torque

A torque adjustment is incorporated in the 746 Operator. FAAC recommends that the gate should stop when it meets with a force of approximately 33 lb (15 kg). To adjust the torque pressure, turn off the main power. Next, hold the drive shaft (with the old-style Manual Release lever or with a 13-mm open-end wrench) and, using a flat-blade screwdriver, turn the clutch adjustment screw clockwise to increase the torque and counterclockwise to lessen the torque (see Fig. 17). Increased torque means more force is required to stop the gate.

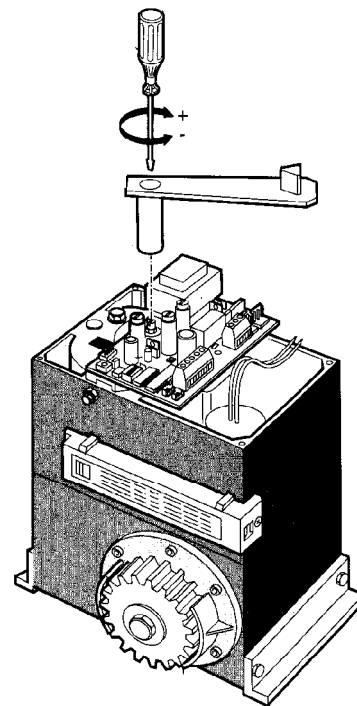

**Figure 17. Adjust the clutch screw to change the torque of the 746 operator**

**Caution:** Do not over tighten the clutch adjustment screw or you may damage the clutch pin.

The torque setting can be adjusted to suit individual requirements by estimating the force of the gate with your hand. The gate should always stop when coming up against a force of about 33 lb (15 kg).

## Finishing the Installation

To finish installing the control panel, be sure the motor is engaged with the Manual Release lever and that the unit is operating in the correct logical operating mode (E1, E2, A1, or A2). Be sure to replace the cover of the 746 Operator.

## Maintenance

Three things need periodic checking on your 746 Operator:

- Oil level
- Clutch adjustment
- Reversing devices

Follow the directions below to check each of these.

### Oil Level

You can visually check the oil in your 746 operator by removing the oil plug. Unscrew the plug so that you can see inside the operator. The oil should cover the copper coil of the motor inside. If necessary, add oil.

Check the oil level in your operator according to the following schedule:

Light duty use: Check once every 2 years

Heavy duty use: Check once every year

### Clutch Adjustment

Every six months you should check the clutch adjustment on your operator. Make sure the gate stops if it encounters a force of about 33 lb (15 kg). Adjust the clutch if necessary.

### Reversing Devices

Every six months you should check that each reversing device installed on your gate system functions properly. Repair or replace any device that does not properly work.



# Troubleshooting

**WARNING!** Turn the main power off before you make any electrical connections or set any switches inside the operator.

If you have a problem installing the operator, check the problems and solutions listed below.

**Problem: The operator does not respond to the activating signal.**

**Solutions:**

Make sure the main power switch is on.

Make sure the Open LED is not steadily illuminated. If it is, remove all wires from terminal 2 to see if that turns off the Open LED. If the Open LED goes off when you unwire terminal 2, check your activating devices.

Check the control panel terminal strip for possible broken or disconnected wires.

If a radio signal is being used to activate the operator, be sure the code sets on both the transmitter and receiver are the same.

Momentarily short across terminals 1 and 2 on the control panel. If this activates the operator and if the Open LED illuminates, a problem probably exists in the activating device itself.

**Problem: The gate is closed and does not open.**

**Solutions:**

Make sure the clutch adjustment is not too weak. Increase the torque if the motor is running and the gate is not moving. This may be necessary for especially heavy gates.

Check that the closed limit switch is working. The FCC status light should be off and the FCA LED should be illuminated. If the FCA LED is not on, the gate leaf has traveled too far in the closing direction.

Make sure that the Manual Release is not preventing the operator from working.

Check fuse F1 and replace it if necessary.

**Problem: The gate opens, but will not close.**

**Solutions:**

If there are no optional reversing devices connected to the control panel, make sure a jumper is installed between terminals 1 and 4 of the control panel.

If optional reversing devices have been installed, check them to see if they are working properly (an activated reversing device will prevent the gate from closing). Temporarily short across terminals 1 and 4 to bypass the reversing devices to see if the gate closes. If the gate closes and if the FTSW LED illuminates, then the problem exists within the reversing device(s).

**Problem: The gate opens and the operator continues to run.**

**Solutions:**

Check the FCA light on the control panel. It should be off. If it is not, check the alignment of the limit switch plate.

If the FCA light is not off and the limit switch plate is correctly adjusted, then replace the limit switch.

**Note:** If the limit switch plates are not detected by the limit switch, the operator will run for approximately 120 seconds and then stop. You will have to reset the control panel if the motor completes its maximum run time. To reset, either cycle the main power off and then on, or press the Reset button on the control panel.

# Exploded View

# 746 Parts

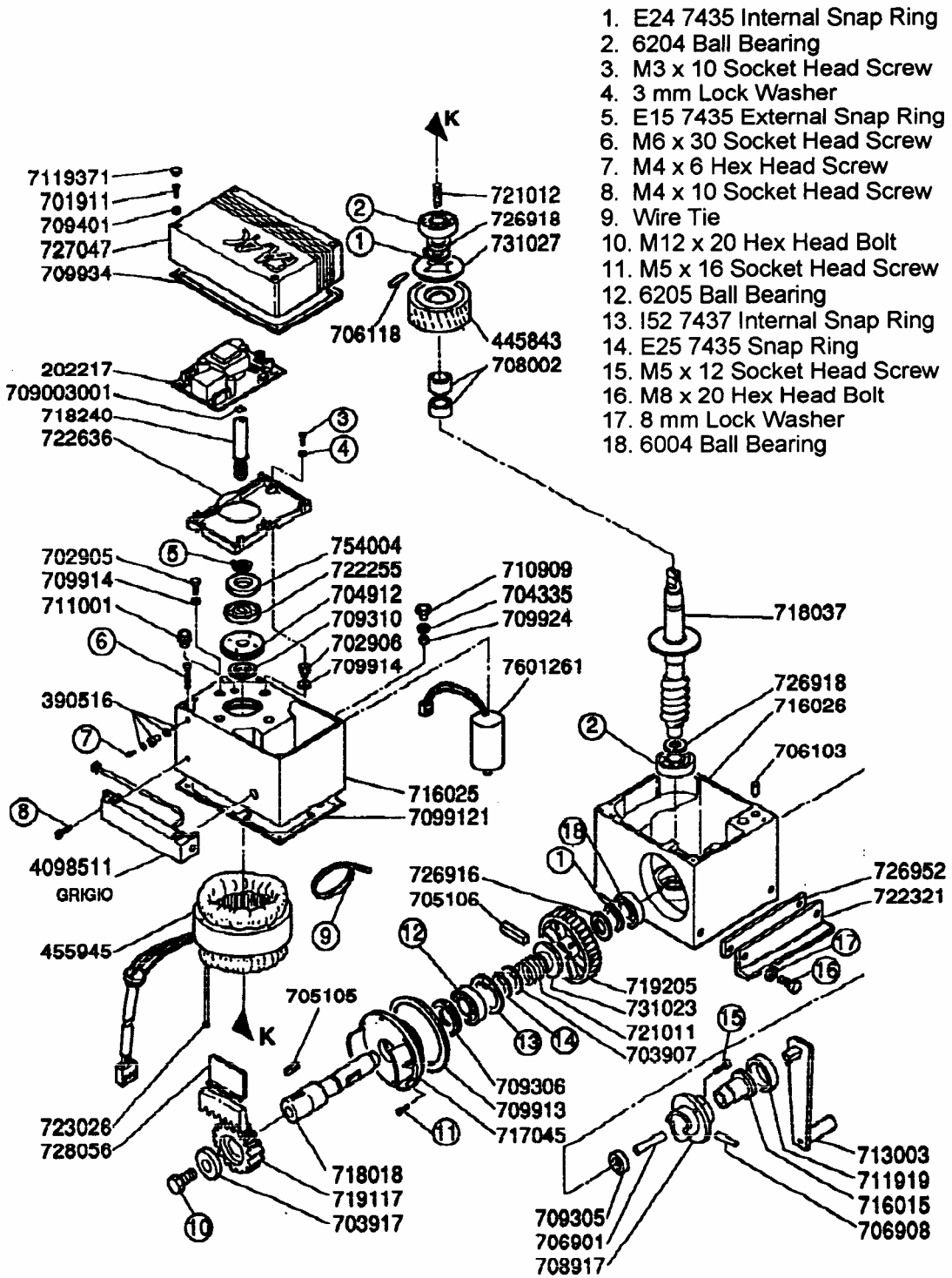

1. E24 7435 Internal Snap Ring
2. 6204 Ball Bearing
3. M3 x 10 Socket Head Screw
4. 3 mm Lock Washer
5. E15 7435 External Snap Ring
6. M6 x 30 Socket Head Screw
7. M4 x 6 Hex Head Screw
8. M4 x 10 Socket Head Screw
9. Wire Tie
10. M12 x 20 Hex Head Bolt
11. M5 x 16 Socket Head Screw
12. 6205 Ball Bearing
13. I52 7437 Internal Snap Ring
14. E25 7435 Snap Ring
15. M5 x 12 Socket Head Screw
16. M8 x 20 Hex Head Bolt
17. 8 mm Lock Washer
18. 6004 Ball Bearing

cod. 9230301

0.0	01.94	00.00	3.90.813.000
-----	-------	-------	--------------



### **Limited Warranty**

*To the original purchaser only:* FAAC International, Inc., warrants, for twenty-four (24) months from the date of invoice, the gate operator systems and other related systems and equipment manufactured by FAAC S.p.A. and distributed by FAAC International, Inc., to be free from defects in material and workmanship under normal use and service for which it was intended *provided* it has been properly installed and operated. FAAC International, Inc.'s obligations under this warranty shall be limited to the repair or exchange of any part of parts manufactured by FAAC S.p.A. and distributed by FAAC International, Inc. Defective products must be returned to FAAC International, Inc., freight prepaid by purchaser, within the warranty period. Items returned will be repaired or replaced, at FAAC International, Inc.'s option, upon an examination of the product by FAAC International, Inc., which discloses, to the satisfaction of FAAC International, Inc., that the item is defective. FAAC International, Inc. will return the warranted item freight prepaid. The products manufactured by FAAC S.p.A. and distributed by FAAC International, Inc., are not warranted to meet the specific requirements, if any, of safety codes of any particular state, municipality, or other jurisdiction, and neither FAAC S.p.A. or FAAC International, Inc., assume any risk or liability whatsoever resulting from the use thereof, whether used singly or in combination with other machines or apparatus.

Any products and parts not manufactured by FAAC S.p.A. and distributed by FAAC International, Inc., will carry only the warranty, if any, of the manufacturer. This warranty shall not apply to any products or parts thereof which have been repaired or altered, without FAAC International, Inc.'s written consent, outside of FAAC International, Inc.'s workshop, or altered in any way so as, in the judgment of FAAC International, Inc., to affect adversely the stability or reliability of the product(s) or has been subject to misuse, negligence, or accident, or has not been operated in accordance with FAAC International, Inc.'s or FAAC S.p.A.'s instructions or has been operated under conditions more severe than, or otherwise exceeding, those set forth in the specifications for such product(s). Neither FAAC S.p.A. or FAAC International, Inc., shall be liable for any loss or damage whatsoever resulting, directly or indirectly, from the use or loss of use of the product(s). Without limiting the foregoing, this exclusion from liability embraces a purchaser's expenses for downtime or for making up downtime, damages for which the purchaser may be liable to other persons, damages to property, and injury to or death of any persons. Neither FAAC S.p.A. or FAAC International, Inc., assumes nor authorizes any person to assume for them any other liability in connection with the sale or use of the products of FAAC S.p.A. or FAAC International, Inc. The warranty hereinabove set forth shall not be deemed to cover maintenance parts, including, but not limited to, hydraulic oil, filters, or the like. No agreement to replace or repair shall constitute an admission by FAAC S.p.A. or FAAC International, Inc., of any legal responsibility to effect such replacement, to make such repair, or otherwise. This limited warranty extends only to wholesale customers who buy directly through FAAC International, Inc.'s normal distribution channels. FAAC International, Inc., does not warrant its products to end consumers. Consumers must inquire from their selling dealer as to the nature and extent of that dealer's warranty, if any.

**This warranty is expressly in lieu of all other warranties expressed or implied including the warranties of merchantability and fitness for use. This warranty shall not apply to products or any part thereof which have been subject to accident, negligence, alteration, abuse, or misuse or if damage was due to improper installation or use of improper power source, or if damage was caused by fire, flood, lightning, electrical power surge, explosion, wind storm, hail, aircraft or vehicles, vandalism, riot or civil commotion, or acts of God.**

**FAAC International, Inc.  
303 Lexington Avenue  
Cheyenne, WY 82007**

746 IM, 6/98