

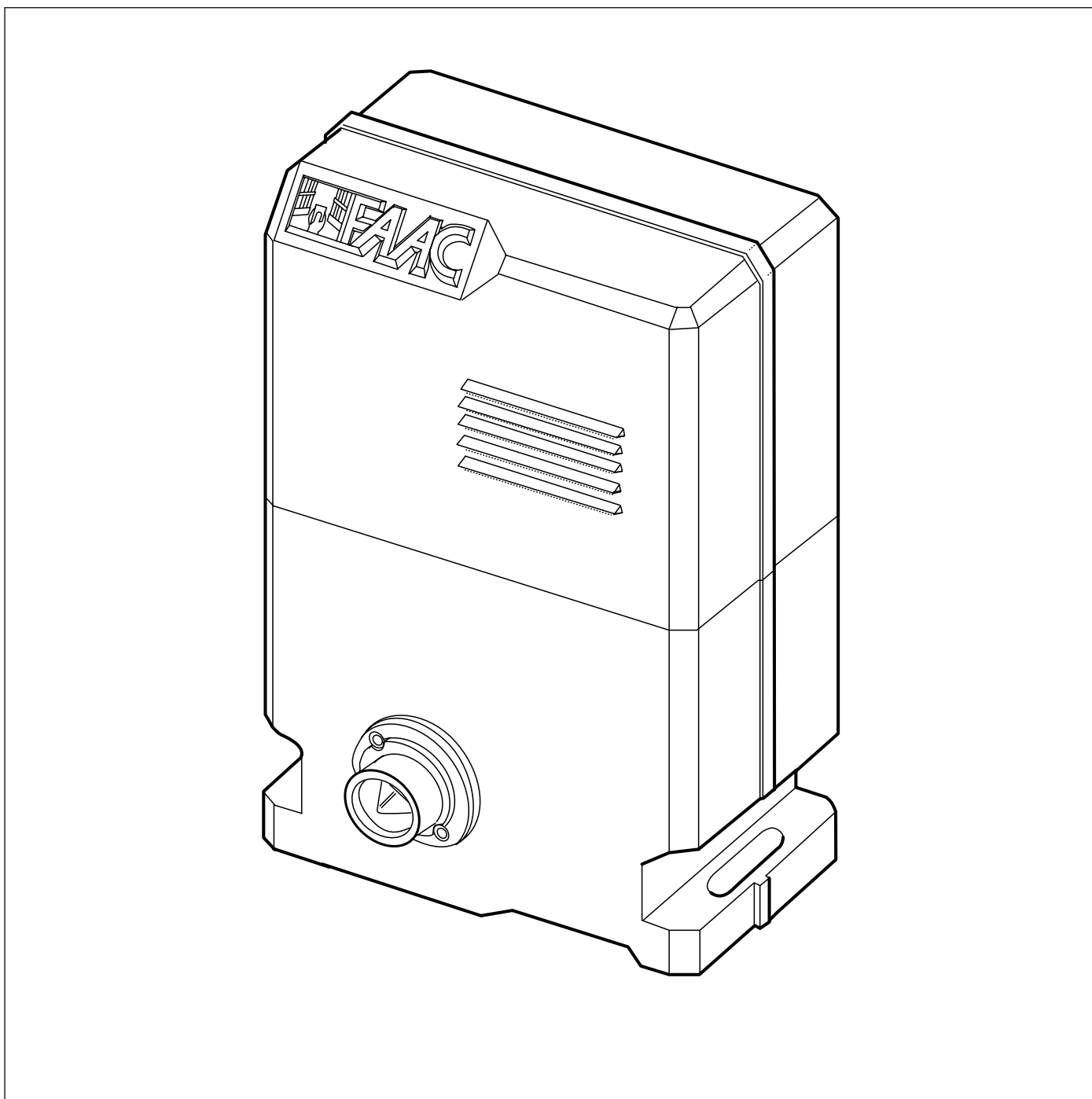

# 820-860



 **FAAC** para la naturaleza  
100% papel reciclado

 **FAAC** ist umweltfreundlich  
100% Altpapier

 **FAAC** pour la nature  
papier recyclé 100%

 **FAAC** for nature  
recycled paper 100%

 **FAAC** per la natura  
carta riciclata 100%



# FAAC



Le descrizioni e le illustrazioni del presente manuale non sono impegnative. La FAAC si riserva il diritto, lasciando inalterate le caratteristiche essenziali dell'apparecchiatura, di apportare in qualunque momento e senza impegnarsi ad aggiornare la presente pubblicazione, le modifiche che essa ritiene convenienti per miglioramenti tecnici o per qualsiasi altra esigenza di carattere costruttivo o commerciale.

The descriptions and illustrations contained in the present manual are not binding. FAAC reserves the right, whilst leaving the main features of the equipments unaltered, to undertake any modifications it holds necessary for either technical or commercial reasons, at any time and without revising the present publication.

Les descriptions et les illustrations du présent manuel sont fournies à titre indicatif. FAAC se réserve le droit d'apporter à tout moment les modifications qu'elle jugera utiles sur ce produit tout en conservant les caractéristiques essentielles, sans devoir pour autant mettre à jour cette publication.

Die Beschreibungen und Abbildungen in vorliegendem Handbuch sind unverbindlich. FAAC behält sich das Recht vor, ohne die wesentlichen Eigenschaften dieses Gerätes zu verändern und ohne Verbindlichkeiten in Bezug auf die Neufassung der vorliegenden Anleitungen, technisch bzw. konstruktiv/kommerziell bedingte Verbesserungen vorzunehmen.

Las descripciones y las ilustraciones de este manual no comportan compromiso alguno. FAAC se reserva el derecho, dejando inmutadas las características esenciales de los aparatos, de aportar, en cualquier momento y sin comprometerse a poner al día la presente publicación, todas las modificaciones que considere oportunas para el perfeccionamiento técnico o para cualquier otro tipo de exigencia de carácter constructivo o comercial.

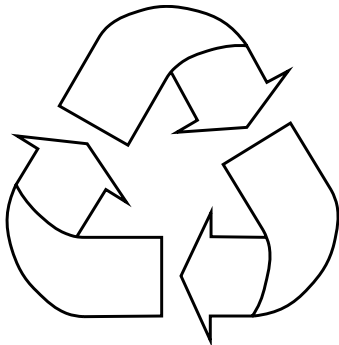

**FAAC per la natura**

- La presente istruzione è realizzata al 100% in carta riciclata.
- Non disperdete nell'ambiente gli imballaggi dei componenti dell'automazione bensì selezionate i vari materiali (es. cartone, polistirolo) secondo prescrizioni locali per lo smaltimento rifiuti e le norme vigenti.

**FAAC for the environment**

- The present manual is produced in 100% recycled paper
- Respect the environment. Dispose of each type of product packaging material (card, polystyrene) in accordance with the provisions for waste disposal as specified in the country of installation.

**FAAC der Umwelt zuliebe**

- Vorliegende Anleitungen sind auf 100% Altpapier gedruckt.
- Verpackungstoffe der Antriebskomponenten (z.B. Pappe, Styropor) nach den einschlägigen Normen der Abfallwirtschaft sortenrein sammeln.

**FAAC écologique**

- La présente notice a été réalisée 100% avec du papier recyclé.
- Ne pas jeter dans la nature les emballages des composants de l'automatisme, mais sélectionner les différents matériaux (ex.: carton, polystyrène) selon la législation locale pour l'élimination des déchets et les normes en vigueur.

**FAAC por la naturaleza.**

- El presente manual de instrucciones se ha realizado, al 100%, en papel reciclado.
- Los materiales utilizados para el embalaje de las distintas partes del sistema automático (cartón, poliestireno) no deben tirarse al medio ambiente, sino seleccionarse conforme a las prescripciones locales y las normas vigentes para el desecho de residuos sólidos.



**FAAC**

FAAC S.p.A.  
Via Benini, 1  
40069 Zola Predosa (BO) - ITALIA  
Tel.: 051/6172411 - Tlx.: 521087  
Fax: 051/758518

Timbro del Rivenditore:/Distributor's Stamp:/Timbre de l'Agent:/ Fachhändlerstempel:/Sello del Revendedor:

**EC MACHINE DIRECTIVE COMPLIANCE DECLARATION**

(DIRECTIVE 89/392 EEC, APPENDIX II, PART B)

**Manufacturer:** FAAC S.p.A.

**Address:** Via Benini, 1  
40069 - Zola Predosa  
BOLOGNA - ITALY

**Hereby declares that:** the 820-860 automation system

- is intended to be incorporated into machinery, or to be assembled with other machinery to constitute machinery in compliance with the requirements of Directive 89/392 EEC, and subsequent amendments 91/368 EEC, 93/44 EEC and 93/68 EEC;
- complies with the essential safety requirements in the following EEC Directives:  
  
73/23 EEC and subsequent amendment 93/68 EEC.  
89/336 EEC and subsequent amendments 92/31 EEC and 93/68 EEC.

and furthermore declares that unit must not be put into service until the machinery into which it is incorporated or of which it is a component has been identified and declared to be in conformity with the provisions of Directive 89/392 EEC and subsequent amendments enacted by the national implementing legislation.

Bologna, 1 January 1997

Managing  
Director

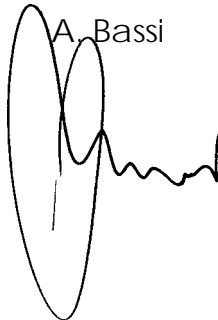
A. Bassi  

## IMPORTANT NOTICE FOR THE INSTALLER

### GENERAL SAFETY REGULATIONS

- 1) **WARNING! FAAC strongly recommends to follow these instructions literally for the safety of persons. Improper installation or misuse of the product will cause very serious damages to persons.**
- 2) Packaging material (plastic, polystyrene etc.) is a potential hazard and must be kept out of reach of children.
- 3) Read the instructions carefully before installing the product.
- 4) Keep these instructions for future reference.
- 5) This product has been designed and manufactured only for the use stated in this manual. Any other use not expressly set forth will affect the reliability of the product and/or could be source of hazard.
- 6) FAAC S.p.A. cannot be held responsible for any damage caused by improper use or different from the use for which the automation system is destined to.
- 7) Do not use this device in areas subject to explosion: the presence of flammable gas or fumes is a serious hazard.
- 8) Mechanical constructive elements must comply with UNI8612, CEN pr EN 12604 and CEN pr EN 12605 standards. Countries outside the EC shall follow the regulations above besides their national normative references in order to offer the utmost safety.
- 9) FAAC cannot be held responsible for failure to observe technical standards in the construction of gates and doors, or for any deformation of the gates which may occur during use.
- 10) Installation must comply with UNI8612, CEN pr EN 12453 and CEN pr EN 12635.  
The degree of safety of the automation must be C+E.
- 11) Before carrying out any operations, turn off the system's main switch.
- 12) An omnipower switch shall be provided for the installation with an opening distance of the contacts of 3 mm or more. Alternatively, use a 6A thermomagnetic breaker with multi-pole switching.
- 13) Ensure that there is a differential switch up-line of the electrical system, with a trip threshold of 0.03A.
- 14) Check that the earthing plant is in perfect condition and connect it to the metallic parts. Also earth the yellow/green wire of the operator.
- 15) The automation is fitted with an anti-crush safety system that is a torque control device. In any case, further safety devices shall be installed.
- 16) The safety devices (e.g. photocells, safety edges, etc.) protect areas where there is a mechanical movement hazard, e.g. crushing, entrapment and cutting.
- 17) Each installation must be fitted with at least one flashing light (e.g. FAAC LAMP, MINILAMP etc.) as well as a warning plate suitably fixed to the gate, besides the safety devices as per point 16. above.
- 18) FAAC cannot be held responsible regarding safety and correct functioning of the automation in the event that parts other than FAAC original parts are used.
- 19) Use only FAAC original spare parts for maintenance operations.
- 20) Do not carry out any modifications to automation components.
- 21) The installer must supply all information regarding manual operation of the system in the event of an emergency and provide the end-user with the "End-user Guide" attached to the product.
- 22) Keep out of persons when the product is in operation.
- 23) Keep out of reach of children the remote radio controls and any control devices. The automation could be operated unintentionally.
- 24) The end-user must avoid any attempt to repair or adjust the automation personally. These operations must be carried out exclusively by qualified personnel.
- 25) **What is not explicitly stated in these instructions is not permitted.**

# AUTOMATION 820 - 860 & 826 MPS

These instructions apply to the following models:  
820 EMC Z20 CR - 820 EMC - 820 EMC RF - 860 MC Z16 - 860 MC - 860 MC RF - 860 EMC Z16 - 860 EMC

The FAAC model 820 and 860 automations for sliding gates are electromechanical operators which transmit movement to the leaf by means of a pinion with rack or chain coupled in an appropriate manner to the sliding gate.

The system is guaranteed to be mechanically locked when the motor is not in operation so a lock does not need to be installed. The gear motors have mechanical/electronic clutches which provide the necessary adjustable anti-crushing safety. A convenient manual release device allows the gate to be operated in the event of a power failure or malfunction. An electronic device allows the open/closed limit switches to be programmed by a simple operation without the need to weld limit switch plates. The electronic control unit is incorporated in the gear motors. The automations 820 - 860 & 826 MPS have been designed and built for vehicle access control. Do not use for any other purpose.

## 1. DESCRIPTION AND TECHNICAL CHARACTERISTICS

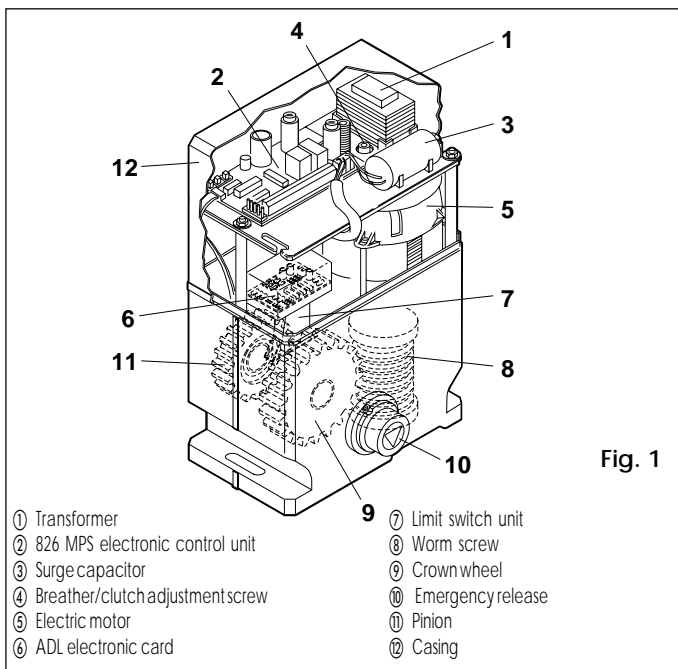

### 1.1. MAXIMUM UTILISATION CURVE

The curve allows the maximum working time (T) to be obtained as a function of duty cycle (F).

For example, the 820-860 gear motors can operate uninterruptedly at a duty cycle of 30%.

To ensure good operation, keep to the field of operation lying below the curve.

**Important:** The curve refers to a temperature of 24°C. Exposure to direct sunlight can result in a reduction in duty cycle to as low as 20%.

#### Calculating duty cycle

The duty cycle is the percentage of effective working time (opening + closing) with respect to the total cycle time (opening + closing + pause times).

It is calculated using the following formula:

$$\%F = \frac{T_a + T_c}{T_a + T_c + T_p + T_i} \times 100$$

where:

T<sub>a</sub> = opening time

T<sub>c</sub> = closing time

T<sub>p</sub> = pause time

T<sub>i</sub> = interval between one complete cycle and the next.

Graph of duty cycle

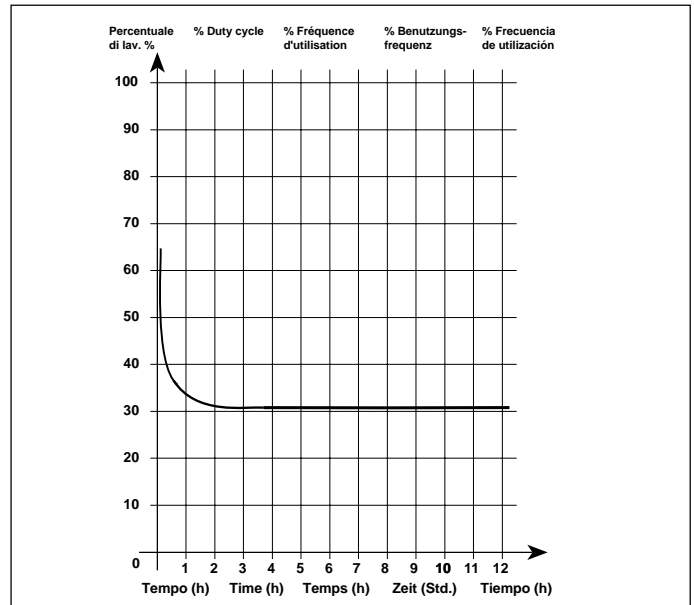

Table 1 Gear motor technical characteristics

MODEL	820	860
Power supply	230 V (+6% -10%)	
Power consumption (W)	400	600
Reduction ratio	1:30	
No. of pinion teeth	Z 16 / Z 20	
Rack	4 module pitch 12.566	
Max. thrust daN	50	110
Winding thermal protection	135 °C	
Duty rating	30% (see graph)	
Oil quantity (l)	0,800	
Type of oil	FAAC XD 220	
Temperature range	-20 to +55°C	
Gear motor weight (kg)	14	15
Housing protection	IP 44	
Max. gate weight (kg)	600	1200
Gate speed	12 m/min	9,6 m/min
Max. gate length	13 m	10 m
Partial opening length	1,60 m	1,20 m
Cooling	self-ventilated	
Clutch	single disc in oil bath	
Housing treatment	cataphoresis	
Casing painting	polyester RAL 7042	
Control unit	826 MPS (incorporated)	
Limit switches	programmable memory (ADL)	
Deceleration	electronic	
Gear motor dimensions LxHxD (mm)	see Fig. 3	

Electric motor technical specifications

Model	820	860
Motor speed (rpm)	1400	1400
Power consumption (W)	400	600
Current draw (A)	2	3
Surge condenser	20 µF	30 µF
Power supply	230 V (+6 -10%) 50 Hz	

2. ELECTRICAL SET-UP (standard system)

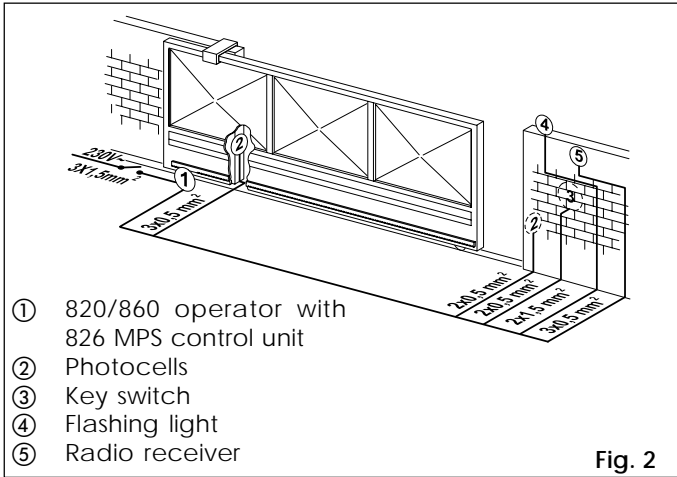

Fig. 2

3. DIMENSIONS

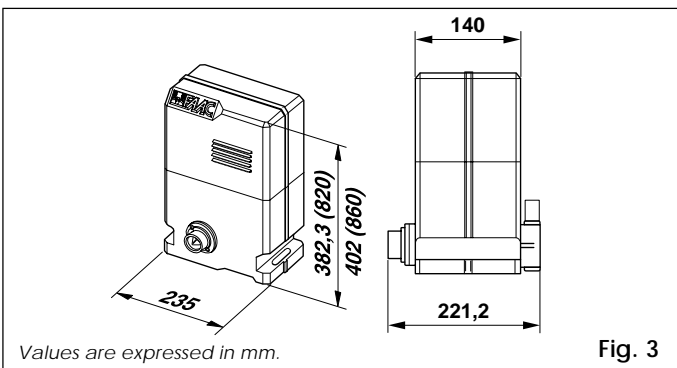

Fig. 3

4. INSTALLING THE AUTOMATION

4.1. PRELIMINARY CHECKS

For safe, correct operation of the automation, make sure that the following requirements are met:

- The gate's structure must be suitable for automation. Take special care to ensure that the wheels are large enough to support the full weight of the gate, that a top runner is installed and that mechanical limit stops are fitted to prevent the gate from coming off the runner.
- The characteristics of the ground must ensure sufficient support for the foundation plinth.
- There must be no pipes or electrical cables in the area to be dug for installing the foundation plinth.
- If the gear motor is located in a vehicle transit area, it is a good idea to provide protection against accidental collisions.
- Check that the gear motor has an efficient earth connection.

4.2. INSTALLING THE BASE PLATE

- 1) The base plate must be positioned as shown in Fig. 4 (right-handed closure) or Fig. 5 (left-handed closure) to ensure that the pinion and rack mesh correctly.

**N.B.:** It is advisable to install the base plate on a concrete base raised about 50 mm from the ground (Fig. 7).

- 2) Assemble the foundation plate as shown in Fig. 6.
- 3) Prepare a foundation plinth as shown in Fig. 8 and install the base plate providing one or more conduits for electrical cables. Use a level to check that the plate is perfectly horizontal and wait for the cement to set.
- 4) Set up the electrical cables for connection to the

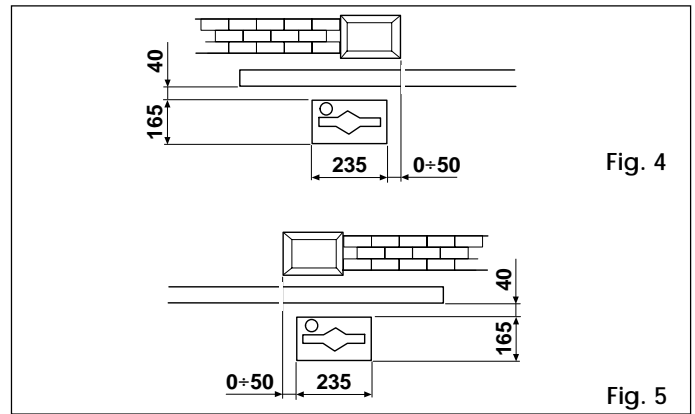

Fig. 4

Fig. 5

accessories and the electricity supply as described in section 2. For ease of connection, ensure that the cables protrude by about 45 cm from the hole in the base plate.

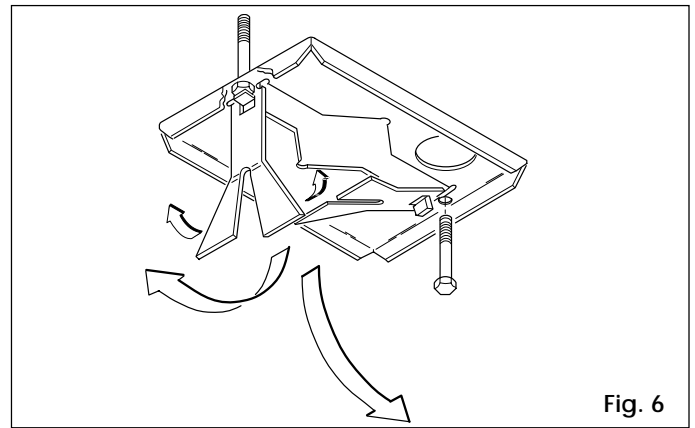

Fig. 6

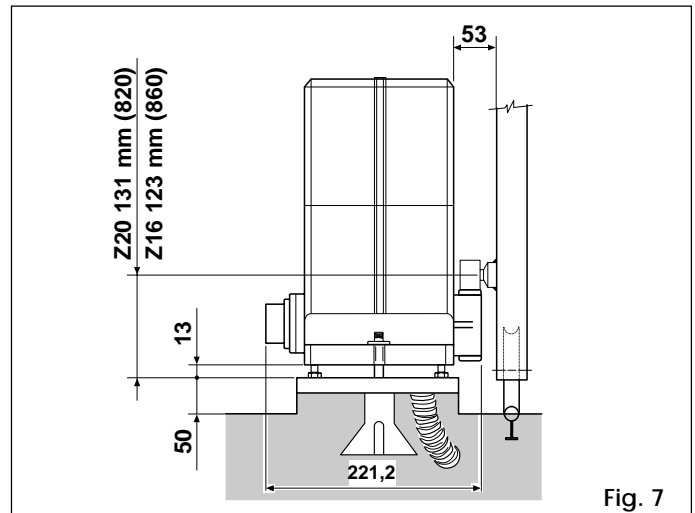

Fig. 7

4.3. MECHANICAL INSTALLATION

- 1) With the aid of a Teflon hammer insert the adjustable feet into the hexagonal holes under the base of the gear motor as shown in Fig. 9.
- 2) Remove the casing and position the gear motor on the foundation plate, threading the electrical cables into the conduit in the operator body.
- 3) Adjust the height of the feet and the distance from the gate as shown in Fig. 7.
- 4) Secure the gear motor onto the base plate using the two nuts and the plates provided as shown in Fig. 10.
- 5) Set up the operator for manual operation as described in section 6.
- 6) Remove the breather screw as shown in Fig. 11 and keep it in a safe place.

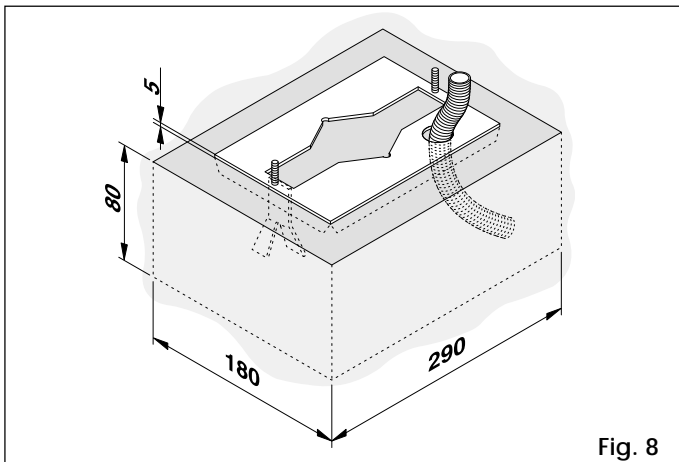

Fig. 8

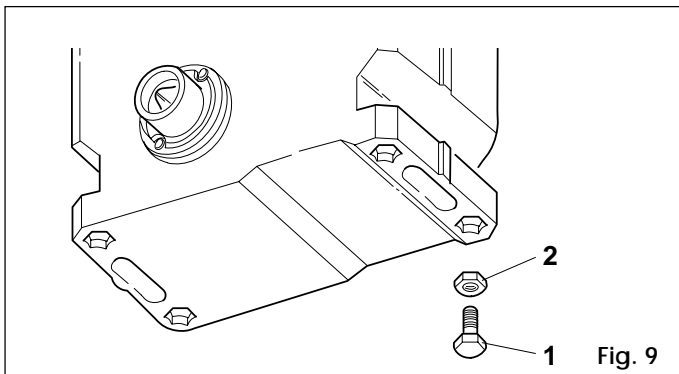

Fig. 9

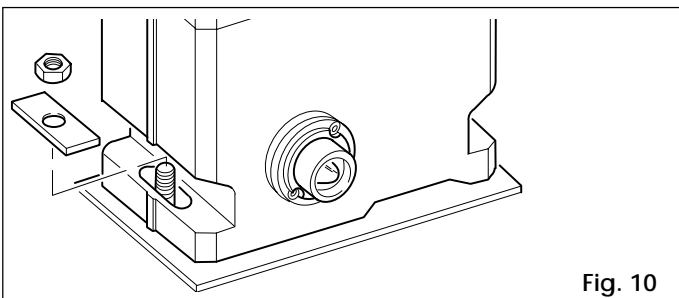

Fig. 10

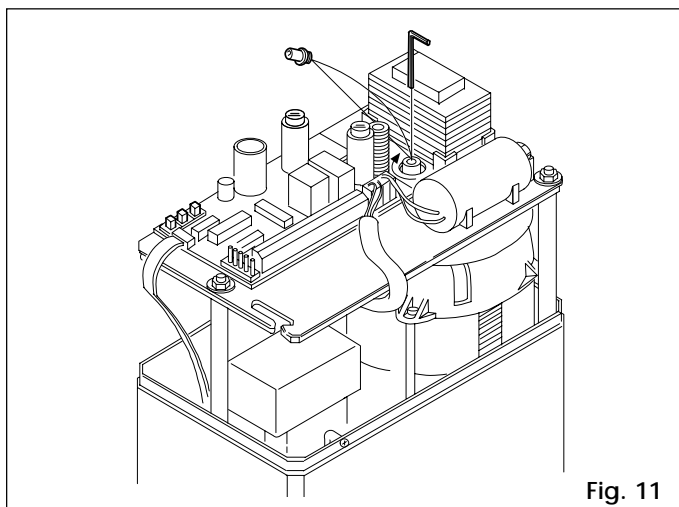

Fig. 11

**4.4. MOUNTING THE RACK**

**4.4.1. WELD-ON STEEL RACK (Fig. 12)**

- 1) Mount the three threaded pawls on the rack element, positioning them in the upper part of the slot. This way the play provided by the slot will allow for future adjustment.
- 2) Slide the leaf manually to the closed position.

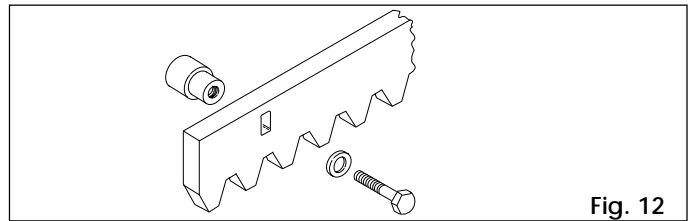

Fig. 12

- 3) Rest the first rack element level on the pinion and weld the threaded pawl onto the gate as shown in Fig. 15.
- 4) Slide the gate manually making sure that the rack rests on the pinion. Weld the second and third pawls.
- 5) Place another rack element next to the first and use a section of rack to set the teeth of the two elements in phase as shown in Fig. 16.
- 6) Open the gate manually and weld the three threaded pawls. Proceed in this manner until the entire gate has been covered.

**4.4.2. SCREW-ON STEEL RACK (Fig. 13)**

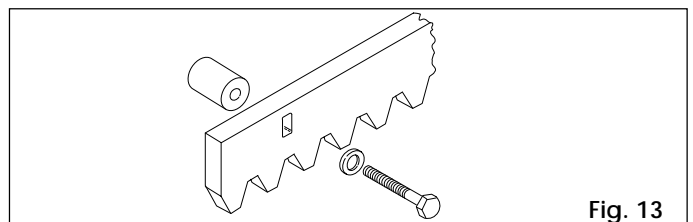

Fig. 13

- 1) Slide the leaf manually to the closed position.
- 2) Rest the first rack element level on the pinion and insert the spacer in the upper part of the slot between the rack and the gate.
- 3) Mark the point to be drilled on the gate. Drill a 6.5 mm diameter hole and thread using 8 mm screw taps. Tighten the bolt.
- 4) Slide the gate manually making sure that the rack rests on the pinion and repeat the operations of point 3.
- 5) Place another rack element next to the first and use a section of rack to set the teeth of the two elements in phase as shown in Fig. 16.
- 6) Slide the gate manually and secure the rack element in the same manner as the first element. Proceed in this manner until the entire gate has been covered.

**4.4.3. SCREW-ON NYLON RACK (Fig. 14)**

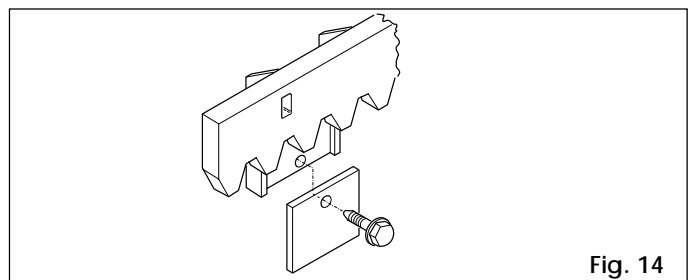

Fig. 14

- 1) Move the leaf manually to the closed position.
- 2) Rest the first rack element level on the pinion and mark the point to be drilled on the gate. Drill a 4 mm diameter hole and screw on the 6x20 mm self-tapping screw with reinforcement plate.
- 3) Move the gate manually making sure that the rack rests on the pinion and repeat the operations of point 2.
- 4) Place another rack element next to the first using a section of rack to set the teeth of the two elements in phase as shown in Fig. 16.
- 5) Move the gate manually and carry out the fixing operations the same way as for the first element. Proceed in this manner until the entire gate has been covered.

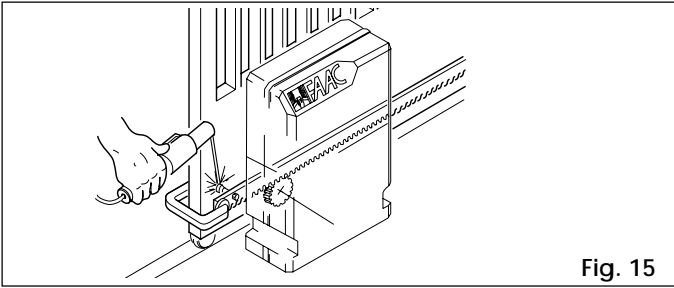

Fig. 15

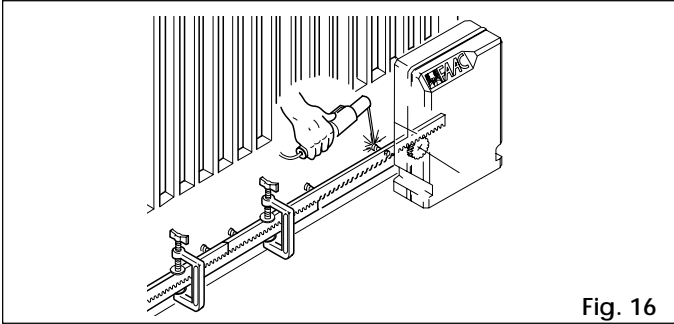

Fig. 16

**N.B.:** Check that none of the rack elements come off the pinion during the movement of the gate.

**Important:** Do not weld the rack elements either to the spacers or to each other (for steel rack only).

After installing the rack, lower the position of the gear motor by adjusting the feet (Fig. 17) by about 1.5 mm to ensure correct meshing with the pinion.

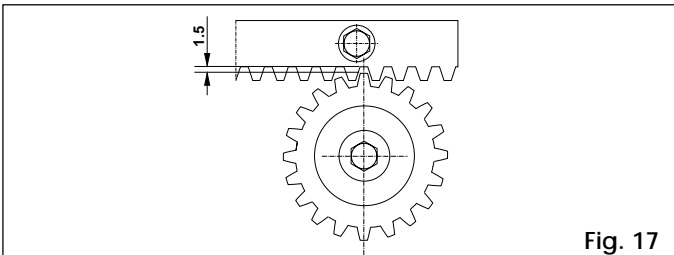

Fig. 17

Check manually that the gate reaches the mechanical travel limits correctly and that it does not encounter friction during its travel.

Do not use grease or other lubricants between the pinion and the rack.

#### 4.5. MOUNTING CHAIN PINIONS

In versions for chain and idle transmission applications, mount the Z16 or Z20 chain pinion. Proceed as follows:

##### 4.5.1 MODEL 820 EMC - 860 MC - 860 EMC (figs. 18-19)

- Insert the elastic pin in the shaft with the aid of a hammer.
- Fit the chain pinion on the shaft by matching up the pinion seats with the elastic pin and tighten up the screw with the washers.

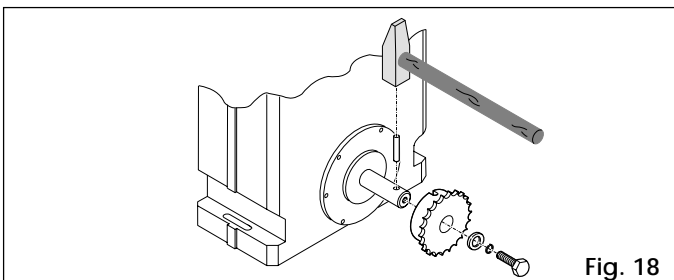

Fig. 18

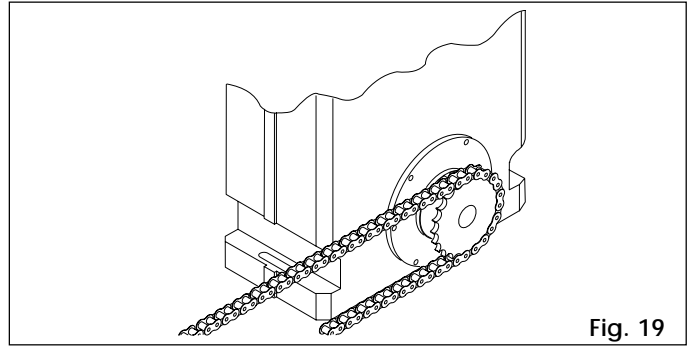

Fig. 19

##### 4.5.2 MODEL 820 EMC RF - 860 MC RF (figs. 20-21)

- Insert the elastic pin 7 in the shaft with the aid of a hammer.
- Fit the chain pinion on the shaft by matching up the pinion seats with the elastic pin and tighten up screw 4 and washers 5 and 6.
- Fit the idle transmission bracket on the gear motor flange, removing the four upper bolts and replacing them with the 5x12 hex bolts 1 and washers 2 in the kit as shown in Fig. 20.
- Fit the chain as shown in Fig. 21 and mount the casing with screws 1 and washers 3 (Fig. 20).

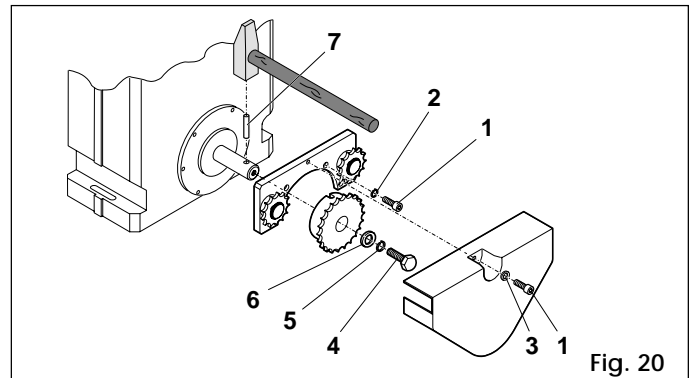

Fig. 20

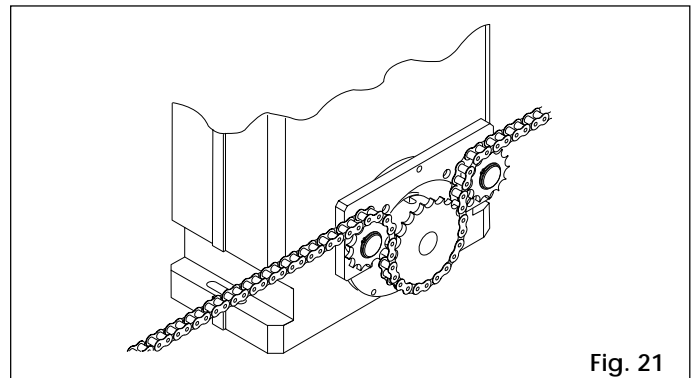

Fig. 21

## 5. START-UP

### 5.1. CONNECTION TO ELECTRONIC CONTROL UNIT

**Warning:** Always turn off the electricity supply before carrying out any work on the electronic control unit (connections, programming, maintenance).

**Warning:** When terminal board J2 is disconnected, high voltage remains on the outputs of the capacitor, motor and transformer power supplies.

Observe points 10, 11, 12, 13 and 14 in the GENERAL SAFETY INSTRUCTIONS.

As shown in Fig. 2, prepare the conduits and make the electrical connections from the 826 MPS electronic control unit to the chosen accessories.



Always route the power supply cables separately from the control and safety cables (keyswitch, receiver, photocells, etc.). Use separate conduits to avoid any interference.

**TABLE 2** TECHNICAL CHARACTERISTICS OF 826 MPS

POWER SUPPLY	230 V (+6 -10%) 50 Hz
MAX. MOTOR LOAD	600 W
MAX. ACCESSORIES LOAD	500 mA
MAX. WARNING LAMP POWER	5 W (24Vac)
TEMPERATURE RANGE	- 20°C + 55°C

**TABLE3** ACCESSORIES CURRENT DRAW

TYPE OF ACCESSORY	NOMINAL CURRENT DRAW
R 31	50mA
PLUS 433 E	20mA
MINIDEC SL / DS	6mA
DECODER SL / DS	20mA / 55mA
RP 433 ESL / EDS	12mA / 6mA
DIGICARD	15mA
METALDIGIKEY	15mA
FOTOSWITCH	90mA
DETECTOR F4 / PS6	50mA
MINIBEAM	70mA

**5.1.1. 826 MPS CONTROL UNIT**

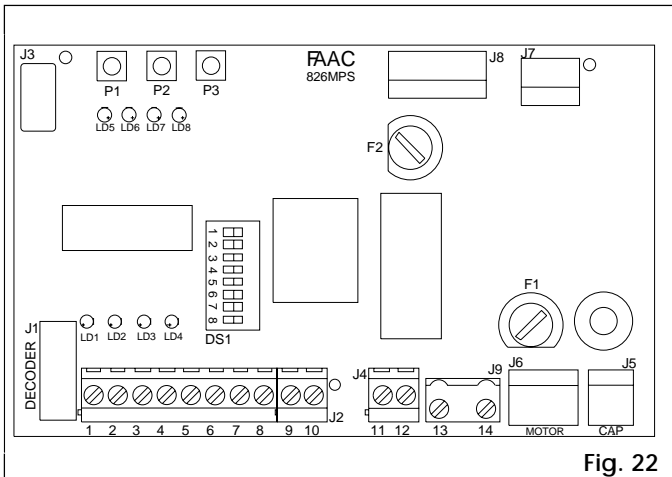
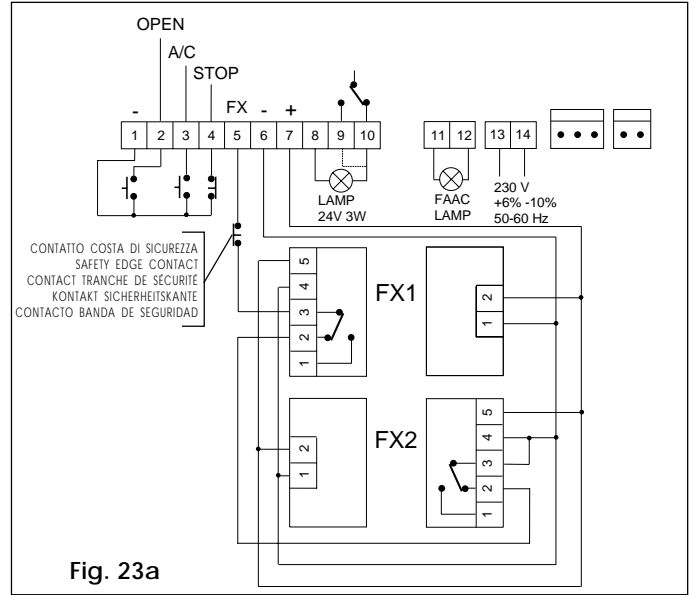

**Fig. 22**

**Table 4** 826 MPS control unit components

LD1	OPEN LED
LD2	PARTIAL OPEN/CLOSE LED
LD3	STOP LED
LD4	SAFETY LED
LD5	LIMIT SWITCH ALARM LED
LD6	OPENING LIMIT SWITCH LED
LD7	CLOSURE LIMIT SWITCH LED
LD8	SLIDING SPEED LED
P1	OPENING LIMIT SWITCH PROGRAMMING BUTTON
P2	CLOSURE LIMIT SWITCH PROGRAMMING BUTTON
P3	LIMIT SWITCH / RESET PROGRAMMING BUTTON
J1	DECODER CONNECTOR
J2	LOW VOLTAGE TERMINAL BLOCK
J3	ADL CONNECTOR
J4	FAAC LAMP OUTPUT TERMINAL BLOCK
J5	CAPACITOR CONNECTOR
J6	ELECTRIC MOTOR CONNECTOR
J7	TRANSFORMER PRIMARY CONNECTOR
J8	TRANSFORMER SECONDARY CONNECTOR
J9	230 Vac POWER SUPPLY TERMINAL STRIP
F1	ELECTRIC MOTOR FUSE (F 5 A)
F2	ACCESSORIES FUSE (T 1.6 A)
DS1	PROGRAMMING DIPSWITCH

**5.1.2. ELECTRICAL CONNECTIONS**



**Fig. 23a**

**5.2. DESCRIPTION OF TERMINAL BLOCK**

**5.2.1. OPEN (terminals 1-2)**

This means any control device with a **N.O.** contact which causes the gate to open when activated. In automatic and semiautomatic logics it is active for both opening and closure.

**5.2.2. A/C (terminals 1-3)**

This means any control device with a **N.O.** contact which causes partial opening of the gate when activated in E1, E2, A1, A2, S1 and S2 logics. In B and C logics it causes the gate to close.

**5.2.3. STOP (terminals 1-4)**

This means a control device with a **N.C.** contact which causes the gate status (opening-pause-closure) to be interrupted until the next impulse is sent.

**N.B.:** If stop devices are not connected, jumper terminals 1-4.

**5.2.4. SAFETY FX (terminals 5 - 6)**

This means all devices (photocells, safety edges, magnetic loops) with a **N.C.** contact which stop the movement of the gate when an obstacle is present in the area protected by the safety devices.

**N.B.:** If stop devices are not connected, jumper terminals 5-6.

**5.2.5. + - LOW VOLTAGE POWER SUPPLY (terminals 6 - 7)**

These are the 24 Vdc terminals to which the accessories must be connected.

Proceed as shown in Table 3 in order not to exceed the maximum permitted load.

**5.2.6. LAMP (terminals 8 - 9 - 10)**

These are the 24 Vac terminals to which the warning lamp must be connected.

Warning lamp operation illustrated in Fig. 24 refers to connection to terminals 8-9. Connecting the warning lamp to terminals 8-10 gives inverse operation.

**5.2.7. FAAC LAMP (terminals 11 - 12)**

These are the 230 Vac terminals to which the flashing light must be connected.

**5.2.8. 230 V MAINS SUPPLY (terminals 13 - 14)**

These are the terminals to which the 230 Vac electricity supply must be connected.

Connect the earth cable to the post as shown in Fig. 23b.

**5.2.9. BEHAVIOUR OF SAFETY DEVICES**

The safety devices operate during closure only. In A1, E1 and S1 logics, interrupting the safety device contacts causes the gate to stop closing and start opening immediately. In

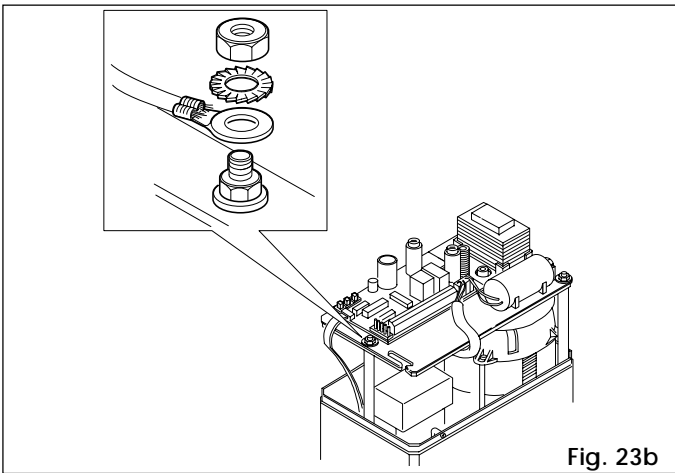

Fig. 23b

A2, E2 and S2 logics interrupting the safety device contacts causes the gate to stop closing, then to start opening again when the safety devices are released.

**5.2.10. ELECTRONIC SAFETY DEVICE**

(models 820 EMC - 860 EMC only)

The operator is equipped with a system which cuts in when it senses a 20% reduction in pinion speed. The device inverts the closing movement and inhibits opening movement. When this safety device cuts in, LED S goes out for a few seconds. Automatic re-closure is inhibited if the electronic anti-crushing safety has cut in.

**5.3. DIPSWITCH SETTINGS**

**N.B.:** PRESS THE RESET BUTTON AFTER ALL PROGRAMMING OPERATIONS

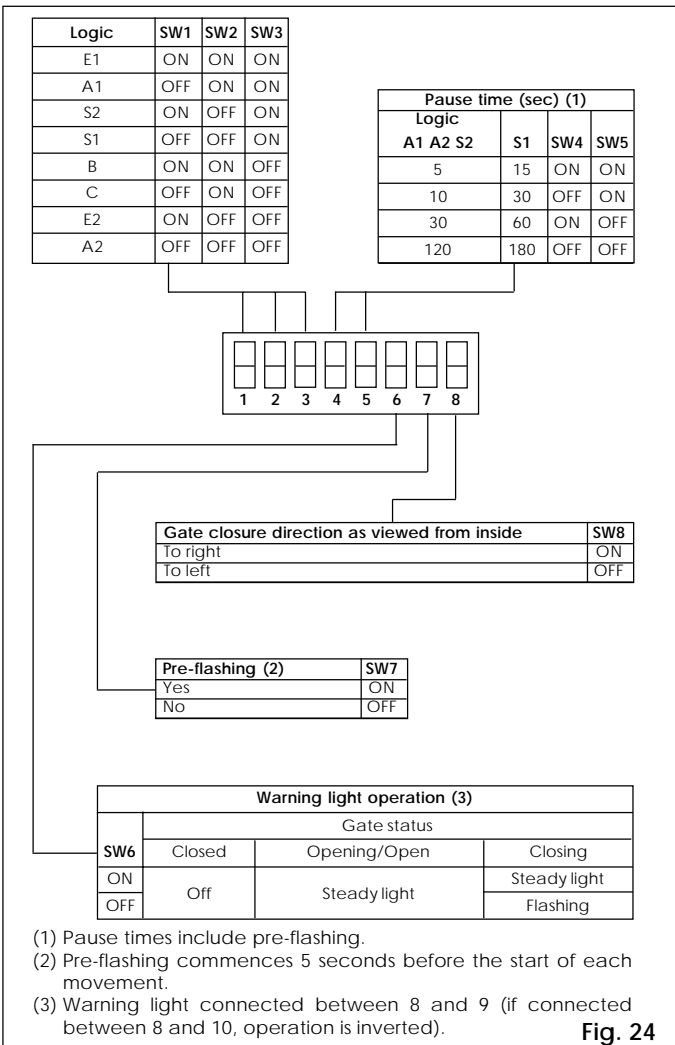

Fig. 24

**5.4. OPERATION IN VARIOUS LOGICS**

**TABLE 5 LOGIC E1 (SEMI-AUTOMATIC)**

LOGIC E1	IMPULSES			
	GATE STATUS	OPEN - A/C (1) -	STOP	SAFETY
CLOSED	opens (2)	no effect	no effect	no effect
OPEN	recloses (2)	no effect	no effect	no effect
CLOSING	inverts motion	stops	stops	inverts motion
OPENING	stops	stops	stops	no effect
STOPPED	recloses (reopens when safety devices are engaged) (2)	no effect	no effect	no effect

**TABLE 6 LOGIC E2 (SEMI-AUTOMATIC)**

LOGIC E2	IMPULSES			
	GATE STATUS	OPEN - A/C(1)-	STOP	SAFETY
CLOSED	opens (2)	no effect	no effect	no effect
OPEN	recloses (2)	no effect	no effect	no effect
CLOSING	inverts motion	stops	stops	stops and inverts motion when disengaged (2)
OPENING	stops	stops	stops	no effect
STOPPED	recloses (reopens when safety devices are engaged) (2)	no effect	no effect	no effect

**TABLE 7 LOGIC A1 (AUTOMATIC)**

LOGIC A1	IMPULSES			
	GATE STATUS	OPEN - A/C (1) -	STOP	SAFETY
CLOSED	opens and recloses after pause time (2)	no effect	no effect	no effect
OPEN	recloses after 5 s (3)	stops counting	stops counting	freezes pause until disengagement
CLOSING	inverts motion	stops	stops	inverts motion
OPENING	no effect	stops	stops	no effect
STOPPED	recloses (2)	no effect	no effect	no effect

**TABLE 8 LOGIC A2 (AUTOMATIC)**

LOGIC A2	IMPULSES			
	GATE STATUS	OPEN - A/C (1) -	STOP	SAFETY
CLOSED	opens and recloses after pause time (2)	no effect	no effect	no effect
OPEN	recloses after 5 s (3)	stops counting	stops counting	recloses after 5 s
CLOSING	inverts motion	stops	stops	stops and inverts motion when disengaged (2)
OPENING	no effect	stops	stops	no effect
STOPPED	recloses (2)	no effect	no effect	no effect

**TABLE 9 LOGIC S1 (SAFETY)**

LOGIC S1	IMPULSES			
	GATE STATUS	OPEN - A/C (1) -	STOP	SAFETY
CLOSED	opens and recloses after pause time (2)	no effect	no effect	no effect
OPEN	recloses immediately (2 and 3)	stops counting	stops counting	recloses after 5 s
CLOSING	inverts motion	stops	stops	inverts motion
OPENING	inverts motion	stops	stops	no effect
STOPPED	recloses (2)	no effect	no effect	no effect

**TABLE 10 LOGIC S2 (SAFETY)**

LOGIC S2	IMPULSES			
	GATE STATUS	OPEN - A/C (1) -	STOP	SAFETY
CLOSED	opens and recloses after pause time (2)	no effect	no effect	no effect
OPEN	recloses immediately (2 and 3)	stops counting	stops counting	freezes pause until disengagement
CLOSING	inverts motion	stops	stops	stops and inverts motion when disengaged (2)
OPENING	inverts motion	stops	stops	no effect
STOPPED	recloses (2)	no effect	no effect	no effect

**TABLE 11 LOGIC B (SEMI-AUTOMATIC)**

LOGIC B	IMPULSES				
	GATE STATUS	OPEN	A/C (5)	SAFETY (until disengagement)	STOP
CLOSED	opening (2)	no effect	no effect	no effect	no effect
OPEN	no effect	closing (2)	inhibits closing	inhibits closing	no effect
CLOSING	no effect	no effect	stops	stops	stops movement
OPENING	no effect	no effect	no effect	no effect	stops movement
STOPPED	completes opening (2)	completes opening (2)	inhibits closing	inhibits closing	no effect

TABLE 12 LOGIC C (DEADMAN)

LOGIC C	IMPULSES				
	GATE STATUS	OPEN (4)	A/C (4 and 5)	SAFETY (until disengagement)	STOP
CLOSED	opens	no effect	no effect	no effect	no effect
OPEN	no effect	closes	inhibits closing	no effect	no effect
CLOSING	no effect		stops	stops	
OPENING		no effect	no effect	stops	
STOPPED	completes opening	completes closing	inhibits closing	no effect	

- (1) The A/C input enables partial opening.
- (2) With pre-flashing selected movement starts after 5 seconds.
- (3) If the impulse is sent after pre-flashing the timer recounts.
- (4) For operation in C logic keep the pushbutton depressed. Movement stops upon release.
- (5) The A/C input controls closure.

**5.5. PROGRAMMING LIMIT SWITCHES**

**IMPORTANT: CHECK THE LENGTH OF THE GATE. THE OPERATOR HAS A LIMIT SWITCH SYSTEM WHICH ALLOWS FOR AUTOMATION OF GATES WITH A MAXIMUM LENGTH OF 13 m FOR MODELS 820 (Z 20 PINION) AND 10 m FOR MODELS 860 (Z 16 PINION).**

**FAILURE TO OBSERVE THESE RECOMMENDATIONS WILL ADVERSELY AFFECT OPERATION OF THE ADL LIMIT SWITCH.**

- 1) To facilitate installation, it is advisable to program the control unit in E1 logic (semi-automatic) by positioning the relative dipswitches as follows:

**SW1 - SW2 - SW3 to ON.**

It is also advisable to inhibit pre-flashing by positioning dipswitch SW7 to OFF.

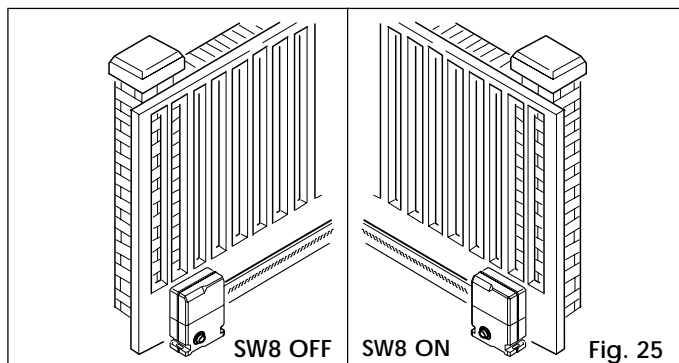

- 2) Position dipswitch SW8 according to the direction in which the gate closes (see Fig. 25) (Rack application).

**IMPORTANT:** In chain applications the dipswitch SW8 must be positioned to ON for closure to left and OFF for closure to right.

The positions of dipswitches SW4, SW5 and SW6 have no effect.

- 3) Move the gate manually to its mid-travel position.
- 4) Switch on the electricity supply to the system and check that the status of the LEDs is as follows:

LED ON	LED OFF
ADL - FCA - FCC S (860) - STOP - FSW	OPEN - A/C - S (820)

**IMPORTANT: MAKE SURE THAT THE GATE IS AT ITS MID-TRAVEL POSITION.**

- 5) Remove the safety tab as illustrated in Fig. 26 and keep it for future maintenance work.
- 6) Open the gate until it is just a few centimetres away from the open position end stop.

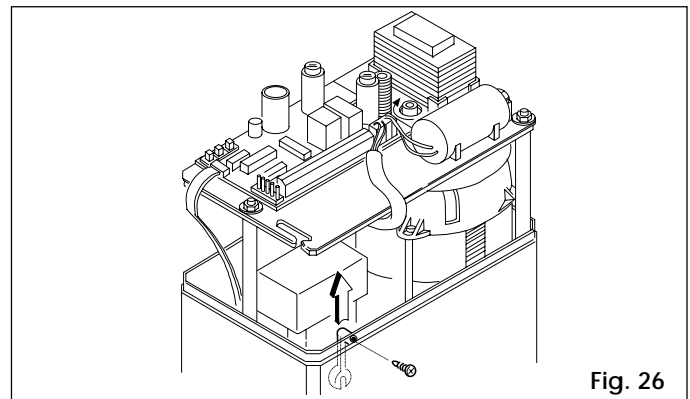

Fig. 26

- 7) Without moving the gate carry out the following operations on the 826 MPS control unit (Fig. 27) in the stated order:

- a) hold down FCA.
- b) press the RESET button for about 1 second. The ADL LED will light up for approximately one second to confirm that the limit switch has been recognised.
- c) release the FCA button.

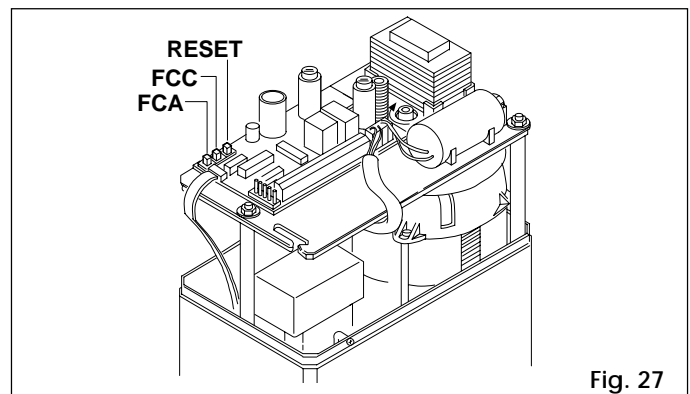

Fig. 27

- 8) Wait for a few seconds, then slide the gate manually until it is a few centimetres from the closed position end stop.
- 9) Without moving the gate carry out the following operations on the 826 MPS control unit (fig. 27) in the stated order:
  - a) hold down FCC.
  - b) press the RESET button for about 1 second. The ADL LED will light up for approximately one second to confirm that the limit switch has been recognised.
  - c) release the FCC button.
- 10) Re-engage the operator by sliding the gate until the release device engages.
- 11) Send an open impulse and check that the gate opens, performs a brief deceleration, then stops at the programmed open position limit switch.
- 12) Send another impulse and check that the gate closes.
- 13) To modify limit switch settings, repeat the sequence of operations from point 3) to point 12).

**IMPORTANT:** If the LED starts flashing quickly (0.25 s) during the limit switch setting operations, follow the instructions given in the **ALARM CONDITIONS** section.

**N.B.:** Any interruption in the power supply will not affect memorisation of the limit switch positions.

If during a manual operation the gate is moved beyond the memorised limit switch positions, a series of open impulses must be sent to move the gear motor to the zone of normal operation.

### 5.6. OPERATION OF ADL LIMIT SWITCH

The ADL limit switch detects the number of pinion rotations by means of a toothed belt transmission. The operator is supplied with the drive in idle and the ADL system positioned in the mid-travel position. Removing the safety tab engages the transmission.

**IMPORTANT:** If the tab has already been removed by mistake, thereby losing the centre-scale position of the ADL, the following steps must be carried out to restore the start condition:

- 1) Release the operator.
- 2) Slide the gate manually to the mid-travel position.
- 3) Remove the rack element so as to free the pinion.
- 4) Turn the pinion by hand clockwise or, if the pinion becomes hard to turn, anticlockwise until the ADL (centre scale) LED lights up continuously.

### 5.7. ALARM CONDITIONS

The ADL LED flashes in the following cases:

- 1) ADL system overrun.
  - 2) Incorrect position of dipswitch SW8.
  - 3) ADL connector removed.
  - 4) Opening/closure time longer than 120 seconds.
- The warning light (if connected) flashes at the same time as the ADL LED.

While this condition is active all the control unit functions are inhibited. It is possible to return to normal conditions only after eliminating the cause of the alarm and pressing the RESET button on the control unit.

**N.B.:** When the warning light flashes with the ADL LED off, this means that fuse F2 has blown.

### 5.8. REGULATING THE TRANSMITTED TORQUE

To regulate the transmitted torque turn the screw on the electric motor shaft (Fig. 11).

To increase the torque, turn the screw clockwise.

To reduce the torque, turn the screw anticlockwise.

**IMPORTANT:** THE OPERATOR IS DELIVERED WITH THE CLUTCH SET TO MAXIMUM, SO THE SCREW MUST BE TURNED ANTICLOCKWISE TO REACH THE OPTIMAL SETTING.

Activate the operator and stop the gate manually to check that the clutch engages. Bear in mind that when this is done with model 820 the electronic anti-crushing device cuts in and stops the movement of the gate if it is opening and reverses it if it is closing.

The electronic anti-crushing device activation threshold depends on the setting of the mechanical clutch.

### 5.9 TESTING THE AUTOMATION

When installation is complete, affix the danger warning label to the top of the casing (Fig. 28). Thoroughly check operation of the automation and all connected accessories.

Give the customer the User Guide. Explain correct use and operation of the gear motor and draw attention to the potential danger zones of the automation.

## 6. MANUAL OPERATION

If it is necessary to operate the gate manually due to a power failure or malfunction of the automation, operate on the release device as follows.

LEVER RELEASE DEVICE (Fig. 29)

- Remove the release device rubber cap.
- Insert the lever provided into the triangular slot release system and turn **clockwise** by about half a revolution.
- Open or close the gate manually.

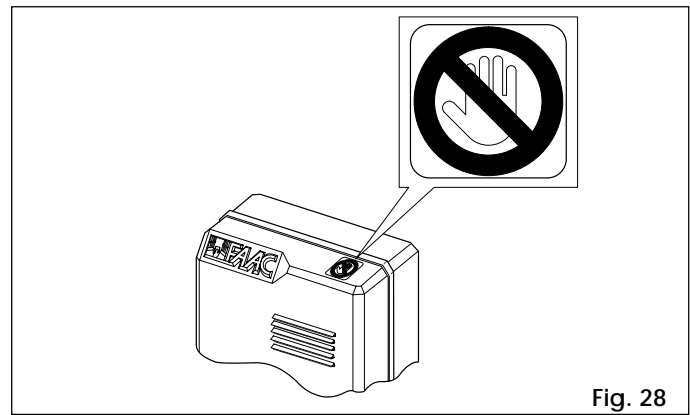

Fig. 28

NUMBERED KEY RELEASE CAP (Fig. 30).

- Open the lock protection flap.
- Insert the key into the lock and turn.
- Turn the release cap **anticlockwise**.
- Perform the gate opening or closing operation manually.
- Turn the release cap **anticlockwise**.

## 7. RETURN TO NORMAL OPERATION

To prevent an accidental impulse from activating the gate during the operation, turn off the electricity supply to the system before relocking the operator.

LEVER RELEASE DEVICE (Fig. 29)

- Insert the lever provided into the triangular slot release device and turn **anticlockwise** by about half a revolution.
- Refit the release device rubber cap
- Move the gate until the release device engages.

NUMBERED KEY RELEASE CAP (Fig. 30).

- Open the lock protection flap.
- Insert the key into the lock and turn.
- Turn the release cap **anti-clockwise**.
- Move the gate until the release device engages.

## 8. MAINTENANCE

When performing maintenance always check that the anti-crushing clutch is correctly regulated and that the safety devices operate correctly.

### 8.1. TOPPING UP WITH OIL

Check the quantity of oil in the operator periodically. For medium-low duty cycles an annual check is sufficient; for more intense use it is advisable to check every 6 months.

The level must not fall below the reference notch on the dipstick attached to the oil filler cap (Fig. 31).

To top up, unscrew the filler cap (Fig. 31) and pour in oil up to the correct level. Use exclusively FAAC XD 220 oil.

## 9. REPAIRS

For repairs contact an authorised FAAC Repair Centre.

## 10. ACCESSORIES AVAILABLE

### 10.1 CORD-OPERATED MANUAL RELEASE

If the gear motor is installed in an inconvenient position, it is advisable to use the accessory shown in Fig. 32 to perform the release operation. Pulling on cord A releases the system, whereas pulling on cord B relocks the gear motor.

**Important:** When the automation is reset, move the gate until the release device engages before sending a control impulse.

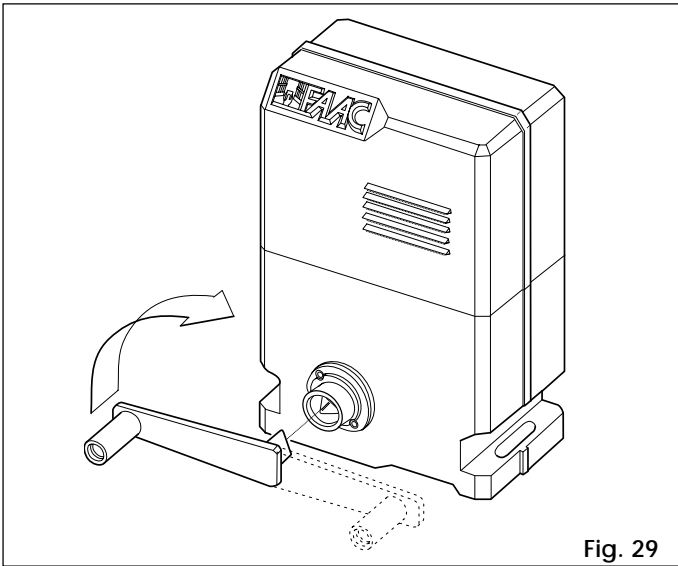

Fig. 29

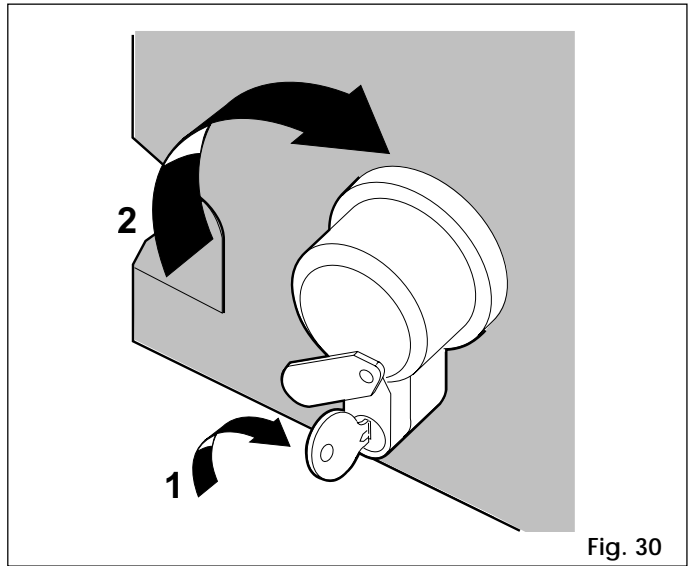

Fig. 30

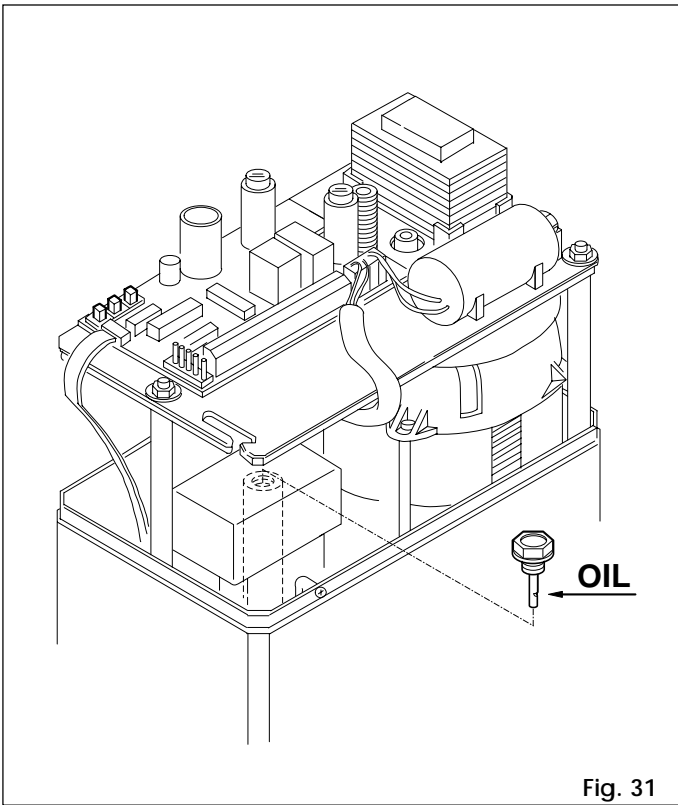

Fig. 31

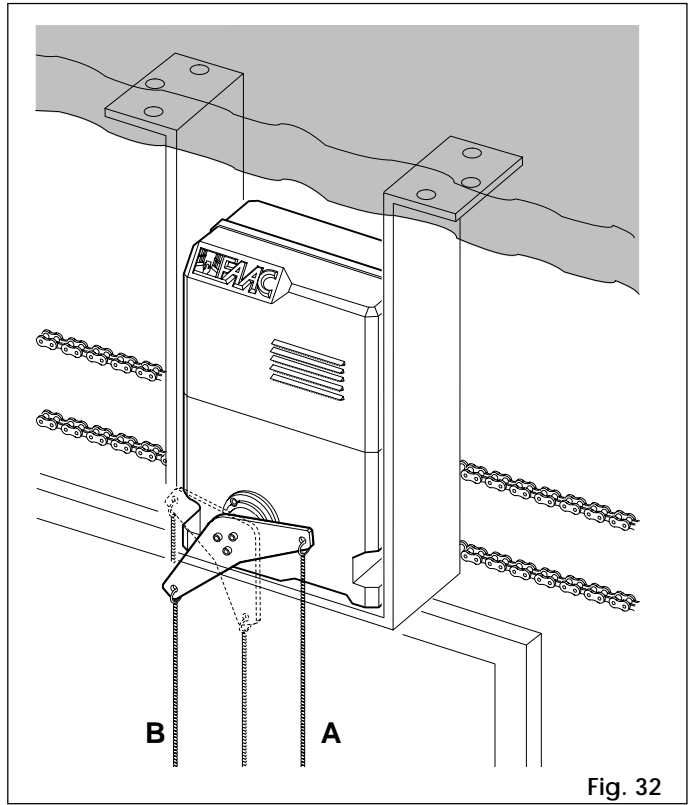

Fig. 32

## USER'S GUIDE

### 820 - 860 AUTOMATION

Read the instructions carefully before using the product and keep them for future reference.

#### GENERAL SAFETY INSTRUCTIONS

If correctly installed and operated, the 820-860 automations ensure a high level of safety.

However, some simple rules should be followed to avoid accidents:

- Do not stand in the vicinity of the automation or allow anyone else, especially children, to do so and do not place objects in the vicinity of the automation. This is particularly important during operation.
- Keep remote controls or any other control device out of the reach of children to prevent them from accidentally operating the automation.
- Do not allow children to play with the automation.
- Do not deliberately obstruct the movement of the gate.
- Make sure that branches or bushes do not interfere with the movement of the gate.
- Keep the luminous signalling systems efficient and clearly visible.
- Do not attempt to operate the gate manually without first releasing it.
- In the event of a malfunction, release the gate to allow access and call a qualified technician for service.
- After setting manual operation, disconnect the electricity supply from the system before returning to normal operation.
- Do not make any modifications to components belonging to the automation system.
- Do not attempt to perform any repair work or tamper with the automation. Call FAAC qualified personnel for repairs.
- At least once every six months have the automation, the safety devices and the earth connection checked by a qualified technician.

#### DESCRIPTION

The FAAC 820 - 860 automations are ideal for controlling vehicle access areas with medium-high transit frequencies. The 820 and 860 for sliding gates are electromechanical operators which transmit movement to the leaf by means of a pinion with rack or chain coupled in an appropriate manner to the sliding gate.

If automatic operation has been selected, sending an impulse causes the gate to reclose on its own after the selected pause time.

If semiautomatic operation has been selected, a second impulse must be sent to reclose the gate.

An opening impulse sent while the gate is reclosing causes it to change direction of movement.

A stop command (if available) stops movement at any time. For detailed information on operation of the sliding gate in the various operating modes, contact the installation technician.

The automations have safety devices (photocells) which prevent the gate from reclosing when an obstacle lies within the area they are protecting.

The system ensures mechanical locking when the motor is not in operation, so it is not necessary to install a lock.

For this reason the release system must be used for manual opening.

The gear motors have mechanical/electronic clutches which offer the necessary anti-crushing safety. An electronic device allows the open/closed limit switch positions to be programmed. The electronic control unit is incorporated in the gear motors.

A convenient manual release device allows the gate to be operated in the event of a power failure or malfunction. The light flashes while the gate is moving.

#### MANUAL OPERATION

If the gate has to be operated manually due to a power failure or malfunction of the automation, use the release device as follows.

LEVER RELEASE DEVICE (Fig. 1)

- Remove the release device rubber cap.
- Insert the lever provided into the triangular slot release system and turn **clockwise** by about 1/2 a revolution.
- Open or close the gate manually.

NUMBERED KEY RELEASE CAP (Fig. 2)

- Open the lock protection flap.
- Insert the key in the lock and turn.
- Turn the release cap **clockwise**.
- Open or close the gate manually.

#### RETURN TO NORMAL OPERATION

To prevent an accidental impulse from activating the gate during the operation, turn off the electricity supply to the system before relocking the operator.

LEVER RELEASE DEVICE (Fig. 1)

- Insert the lever provided into the triangular slot release device and turn **anticlockwise** by about half a revolution.
- Refit the release device rubber cap.
- Move the gate until the release device engages.

NUMBERED KEY RELEASE CAP (Fig. 2).

- Open the lock protection flap.
- Insert the key into the lock and turn.
- Turn the release cap **anti-clockwise**.
- Move the gate until the release device engages.

