

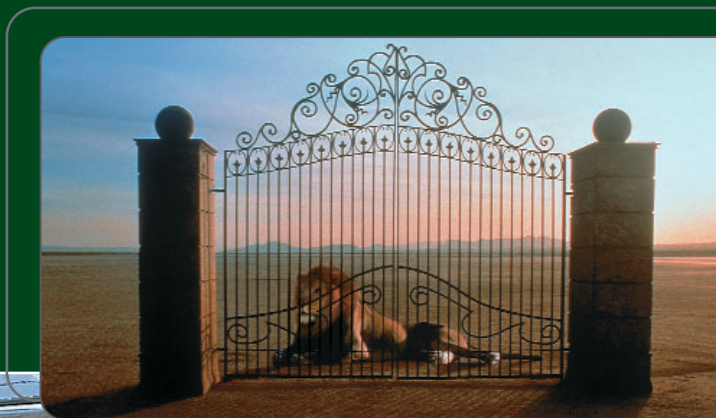

Opening a Whole New World: FAAC Slide Gate Systems



Model 885

The Model 885 slide gate operator is designed for both residential and commercial applications. This sophisticated 1 horsepower, chain driven, 115 VAC operator can handle a 35 foot entrance opening and a maximum gate weight of 1,800 pounds.



- Swing Gate Operators
- Slide Gate Operators
- Barrier Gate Operators
- Accessories

FAAC USA

An ISO 9001 Certified Company

FAAC is the world's largest specialized manufacturer of gate operating equipment.

**UL 325
COMPLIANT**
CSI # 02820 -
Gate Operators

Model 885 Continuous Duty Slide Gate Operator

**UL 325
COMPLIANT**
CSI # 02820 -
Gate Operators

Model 885 Features

- UL 325 compliant
- Continuous duty operation
- Fully programmable via push button
- Provides "soft stop" on opening and closing
- Reverse on contact
- Full 1 hp motor, chain driven
- Electronic anti-entrapment by encoder
- Manual release has fail-safe or fail-secure capabilities
- Plug-in loop detectors simplify wiring
- Three operating logics to choose from
- Master slave capabilities
- Battery back-up optional
- A convenient manual release is standard.

Model 885 Package Options:

1. Operator-only Package
(for replacement purposes or if installer is supplying chain)
 - One 885 operator with control panel & mounting hardware (includes chain-to-gate kit)
2. Basic Package
 - One 885 operator with control panel & mounting hardware
 - 30 ft of chain and chain-to-gate kit
 - Two photobeam sets for opening and closing reversing devices
 - Two warning signs
3. Loop Detector Package
 - One 885 operator with control panel & mounting hardware
 - 30 ft of chain and chain-to-gate kit
 - Two loop detectors (plug-in):
1 free exit, 1 safety
 - Two photobeam sets for opening and closing reversing devices
 - Two warning signs
4. Battery Back-up Package # 1
(without loop detectors)

- One 885 operator with control panel & mounting hardware
 - 30 ft of chain and chain-to-gate kit
 - One battery back-up kit
 - Two photobeam sets for opening and closing reversing devices
 - Two warning signs
5. Battery Back-up Package # 2
(with loop detectors)
 - One 885 operator with control panel & mounting hardware
 - 30 ft of chain and chain-to-gate kit
 - One battery back-up kit
 - Two loop detectors (plug-in):
1 free exit, 1 safety
 - Two photobeam sets for opening and closing reversing devices
 - Two warning signs

NOTE: To guarantee the safety and efficiency of its equipment, FAAC strongly recommends that qualified personnel test the safety system on an annual basis, as well as maintain the overall hydraulic or mechanical system.

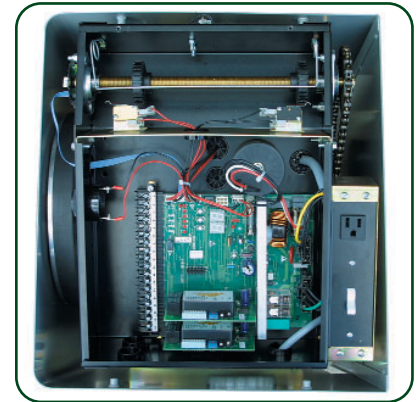

Advanced solid-state electronics provide versatility and reliability



Removable cover provides easy access to electronics.

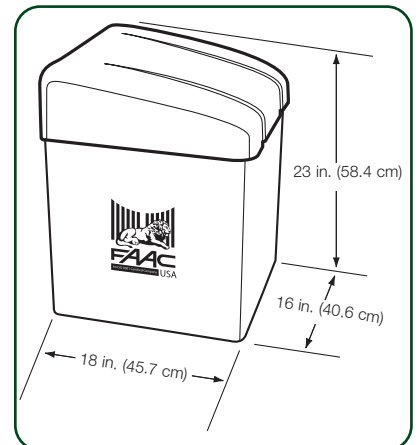

The Model 885 dimensions



Use FAAC to build a complete gate system



Some access control options to open a gate

Telephone entry systems

Loops and photobeam safety

Photobeams and aluminized photobeam stands

Model 885 continuous duty slide gate operator (shown with optional pedestal)

Photobeams

Electric and magnetic locks

Specifications

Parameter	Model 885
Application	Residential, commercial
Duty cycle	Continuous
Maximum gate opening	35 ft (10.7 m)
Maximum gate weight	1,800 lb (816.5 kg)
Operating temperature range	Approx. -4°F to 131°F (-20°C to 55°C)
Voltage/power supply	115 VAC ± 10%, 60 hz
Operator weight	121 lb (45.2 kg)
Housing protection	IP44
Max. amp draw for accessories	1.6
Gate speed	Approx. 1 ft/sec (30.5 cm/sec)
Electric Motor	1 hp, 6 pole, 1200 rpm

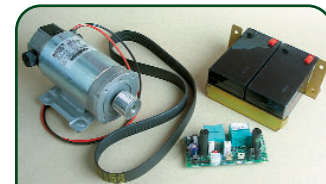

Model 885 Battery Back-up Unit

- 24 vdc motor
- 90 watt
- 1400 rpm
- Adjustable torque
- "One shot" open programmable (fail safe)
- Auto open programmable (fail secure)

UL 325 Class Descriptions & FAAC Operators			
Class	FAAC Models	Duty Cycle	Typical Use
Class 1	400, 412, 402 422, 750, 760 620, 640, 885	Limited duty	• Home use • Small apartment building, up to 4 units per building, limited public access
Class 2	400, 620, 640 885	Continuous duty	• Apartment buildings • Open public access
Class 3	400, 620, 640 885	Continuous Duty	• No public access
Class 4	620, 640, 885	Continuous Duty	• Prison related security



HEADQUARTERS
Bologna, Italy

RESEARCH & DEVELOPMENT
Bologna, Italy
Dublin, Ireland

PRODUCTION FACILITIES
Bologna, Italy

SUBSIDIARY OFFICES
Wals-Siezenheim, Austria
Corbas-Lyon, France
Freilassing, Germany
Alcobendas-Madrid, Spain
Illnau, Switzerland
Basingstoke, Hampshire, U.K.
Cheyenne, Wyoming, U.S.A.

FAAC's U.S.
headquarters
in Cheyenne,
Wyoming

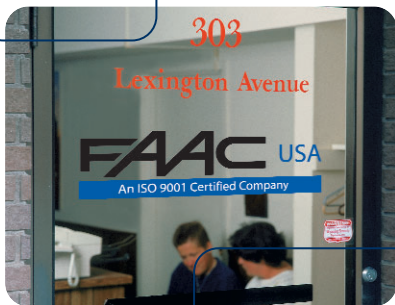

Founded in 1965, FAAC has risen to become the world's largest specialized manufacturer of automated operators for swing, slide and barrier gate systems.

International company headquarters, research & development and primary production facilities are located in Bologna, Italy. Dublin, Ireland is the site of FAAC's research, design and production facility for electronic controls including photocells, radio controls and code opening systems.



FAAC International, Inc.
303 Lexington Avenue
Cheyenne, WY 82007
1-800-221-8278
Fax: (307) 632-8148
Web: www.faacusa.com

