



Implanted-Type Mounting Base

Design Characteristics

- Major advantage of compatible mounting base is to save time on select proper detector for various purpose and able to install the base quickly and continuously during field installation. Afterwards, just plug-in proper detector head to complete the project.
- This unique mounting base is designed to match the original decoration design and visual effect perfectly with detector implanted to ceiling. Furthermore, it will make the entire decoration even looks better.
- This base has optional Power-off Warning feature to ensure that the system will operated normally.

Dimensions

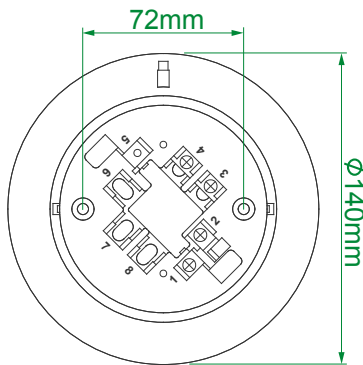

Features

Model	Feature, Application	
AHMB-2	2-wire	Apply to conventional fire alarm control panel.
AHMB-3	3-wire	Auxiliary for remote indicating lamp.
AHMB-4	4-wire	12~24VDC, optional one set of "A" contact . Apply to security system....etc.

Wiring Diagram

2-Wire Type (Regular)

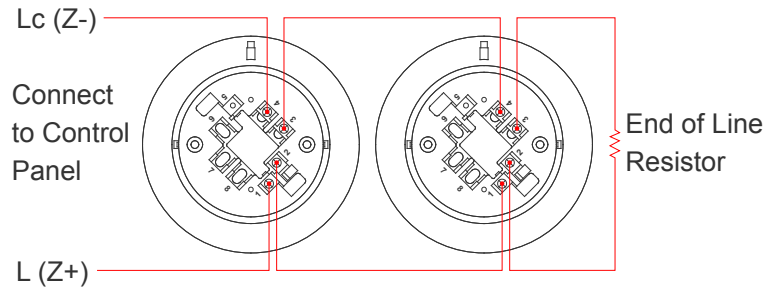

3-Wire Type (Signal Transfer)

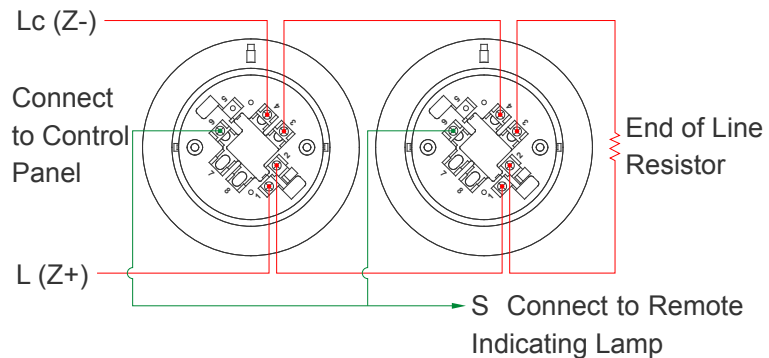

4-Wire Type (Relay Output) Contact Ratings 0.8A @30V DC 0.4A @125V AC

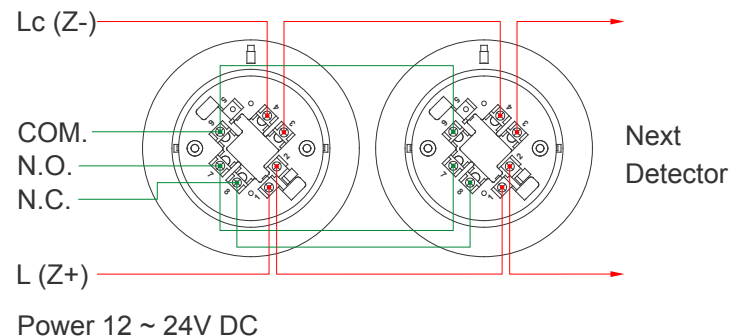

Approvals

CNS