

ENTRYPROX 4045-905 (Rev A)

HID Corporation
9292 Jeronimo Road
Irvine, California
92618 USA
Tel
949.598.1600
800.237.7769
Fax
949.598.1690
www.HIDCorp.com

Introduction	1
Product Overview	2
Unit Capacity.....	2
Transactions	2
Specifications.....	3
Default Settings.....	4
Installing Entryprox.....	4
Assembly Parts.....	4
Mounting the Entryprox Unit.....	6
Wiring the Controller Keypad for a Standard Installation	8
Wiring the Controller Keypad for a Secure Installation	9
UL 294 Compliance Requirements	14
Wiring Entryprox	17
Wiring the Main Relay	18
Wiring the Auxiliary Relay	18
Wiring the Request to Exit Input.....	23
Programming Entryprox	26
Card/PIN Programming.....	30
Changing Operating Parameters	34
Using the Printing Features.....	37
Wiegand Mode.....	42
Program Command Table.....	43
LED/Sounder Status	50
Appendix A	52

INTRODUCTION

This EntryProx User's Guide provides basic information and instructions for installing, wiring, and programming the EntryProx unit.

IMPORTANT

- **YOU MUST KEEP A USER LIST** when programming cards and PIN codes into your EntryProx. Write down the User Location, Card Number, PIN Code and the Name of the User. Use the blank form in Appendix A as a photocopy master.
- **DO NOT PROGRAM A CARD OR PIN IN USER LOCATION 1** for normal access control use. **User Location 1 is reserved for the MASTER CODE**, which places the unit into programming mode.
- **CHANGE THE MASTER CODE** from the factory default, after initial programming, and **write this code down and keep it in a safe place**.
- **IF YOU LOSE OR FORGET THE MASTER CODE:** End Users: contact your dealer –a service call is required. Dealers: call HID Technical Support.
- **CONSIDER A SECURE INSTALLATION** if installing on an exterior door or high-risk location.

FCC WARNING

Changes or modifications not expressly approved by the party responsible for compliance could void the users' authority to operate this equipment. The reader is intended to be powered from a limited power source output of a previously certified power supply.

UL 294 COMPLIANCE

The EntryProx Unit complies with UL 294 Standard for Access Control Units in a standard wall-mount installation, only when installed in strict accordance with UL requirements. Please refer to page 14 for details.

HID CORPORATION

2

PRODUCT OVERVIEW

The EntryProx unit provides card and keypad access control for a single entrance. The unit can be installed in a standard one-stage configuration or a secure two-stage (remote) configuration. (Secure installation will be card-only.)

To gain access to the controlled door, the user presents their card to the reader and / or enters their PIN code into the keypad. The unit searches its memory for that card or PIN code. If the unit finds the card or PIN code, it unlocks the door or performs some other action that has been programmed for that user.

The EntryProx unit is compatible with all HID proximity access cards or key tags encoded with up to 37 bits of data. All programming options are performed using the controller keypad. Manual or batch card/tag programming via the keypad can be completed for 26-bit format only. A batch of cards or tags encoded in any format can be sequentially presented to the reader by entering a single keypad command.

UNIT CAPACITY

The EntryProx unit can accommodate up to 2,000 users. Each user is assigned to a User Location (numbered 1 – 2000), which can have a card/keytag, a PIN code, or a card/keytag **PLUS** a PIN code. User Location 1 is reserved for the Master Code (used for programming, only).

TRANSACTIONS

A maximum of 1,000 transactions can be stored in the EntryProx unit. Each transaction includes the time, the date, the User Location and the event. When maximum capacity is reached, the oldest transactions are overwritten.

PRE-PROGRAMMING THE UNIT BEFORE INSTALLATION

Dealers and installers are advised to pre-program the unit at their offices before installing it at the site. Simply connect it to a 12VDC source, follow configuration and card enrollment instructions at the end of this guide, and disconnect the unit. Programming will be retained in memory. You will spend less time at the site, and by being familiar with programming, will be able to train the end user more effectively.

SPECIFICATIONS

TABLE 1 - SPECIFICATIONS

CATEGORY	REQUIREMENTS
Environmental	
Operating Temperature	-31F to +150F (-35C to +66C) @ 30 VDC
Operating Humidity	5% to 95% relative humidity, non-condensing
Electrical	
Power Supply/Current Requirements	10 - 15V DC, linear, filtered and regulated power supply recommended 150 mA for the EntryProx unit only. Additional capacity required for locking device or peripherals.
Mechanical	
Height	5.25 in (13.3 cm)
Width	2.75 in (7 cm)
Depth	1.625 in (4.1 cm)
Relay Outputs	
Main Relay, Aux Relay	Form C (switches up to 1A inductive load, 2A resistive @ 30VDC)
Sounder	4000 Hz, defeatable
LEDs	Bi-Color (red/green) Amber Infrared

HID CORPORATION

4

DEFAULT SETTINGS

The EntryProx unit is shipped with the following default settings.

PARAMETER	DEFAULT SETTING
Master Code (User Location 1)	1234*
Main Relay energizes for	5 seconds
Audible Keypress Feedback	ON
Local Propped Door Sounder activates after	30 seconds
Local Forced Door Sounder activates immediately for	10 seconds
Printer Output Port	Infrared (IR) port

INSTALLING ENTRYPROX

You can install the EntryProx unit by using a standard installation method or a secure installation method. Both installation methods require that you mount the EntryProx unit to a wall or glass surface.

ASSEMBLY PARTS

Before you install the EntryProx, be sure that you have the correct factory and installer supplied parts.

A. Controller Keypad Unit	I. Silicone Rubber Cushion
B. Controller Keypad Backplate	J. Self-Adhering Pads
C. Cable Assemblies	K. 2-pin Jumper
D. Antenna Backplate	L. Filler Piece
E. Antenna Housing	M. Lithium "Coin Cell" Battery (see warning below)*
F. Blank Label	
G. Mounting Screws	N. Cover screws – hex and tamper.*
H. Press to Exit Label	O. Hex wrench*

* - not shown in Figure 1

FIGURE 1: FACTORY SUPPLIED PARTS

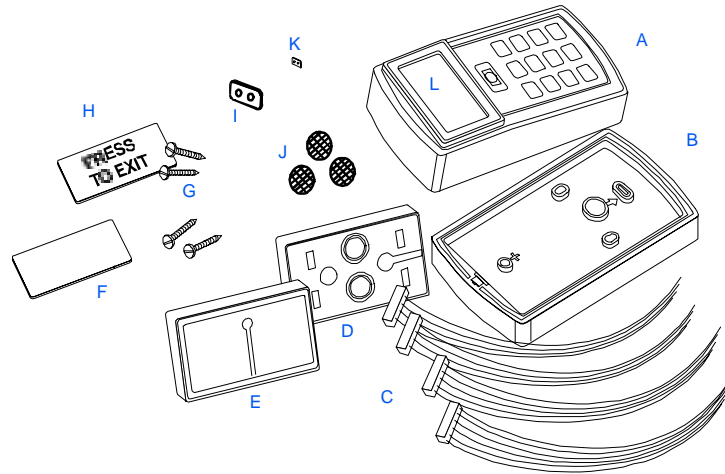

INSTALLER SUPPLIED PARTS LIST

- Appropriate DC power supply (10-15VDC, linear type)
- Appropriate electrical tools
- Recommended remote antenna cable ALPHA 1294C (22AWG)
- Wiegand interface cable ALPHA 1295C (22AWG) (only if using a separate Wiegand access control panel)
- Power supply cable (18AWG - 22AWG)
- Door lock cable (18AWG - 22AWG)
- Door monitor cable (18AWG - 22AWG)
- Request to Exit cable (ALPHA 2421C 18AWG or ALPHA 1292C 22AWG) (only if using remote switch)
- Optional tamper screw bit (only if tamper screw is used)

CAUTION – Replace Battery with Panasonic BR1225 only. Use of another battery may present a risk of fire or explosion. Battery may explode if mistreated. Do not recharge, disassemble or dispose of battery in fire.

MOUNTING THE ENTRYPROX UNIT

If you mount the EntryProx unit to a wall, you can install an electrical junction box to hold the unit and the wires in place. The mounting hole cutouts on the backplate line up with the screw holes on a standard junction box.

If you mount the EntryProx unit to a glass surface **DO NOT** remove the wire exits on the backplate. Remove the appropriate wire exit cutouts located on each side of the controller keypad case.

If your installation must comply with the UL 294 Standard for Access Control, please read Page 14.

PRECAUTIONS FOR OUTDOOR INSTALLATIONS

Water damage is a key cause of unit malfunction, causing corrosion or short circuits. When mounting the unit in an area that will be exposed to rain or moisture, take the following precautionary measures:

1. Use silicone to seal wire runs and mounting holes (antenna is already sealed).
2. Do NOT seal the cover and base together. Water that enters the case must be allowed to run out at the bottom.
3. Bend the wires to form a drip loop before they enter the case. This will prevent water from following the wires into the case.

BEGINNING ENTRYPROX INSTALLATION

To mount the EntryProx unit, refer to Figures 2 and 3 and follow these instructions:

1. Remove the hex screw located at the bottom of the EntryProx unit.
2. Disconnect the backplate of the EntryProx unit from the controller keypad.

3. Remove the wire exits and mounting hole cutouts from the backplate as shown in Fig. 2.
4. Pull the wires through the backplate as shown in Figure 3.
5. Attach the backplate to a wall or glass surface using the mounting screws or the self-adhesive fasteners.

FIGURE 2: REMOVING THE WIRING EXITS AND MOUNTING HOLES

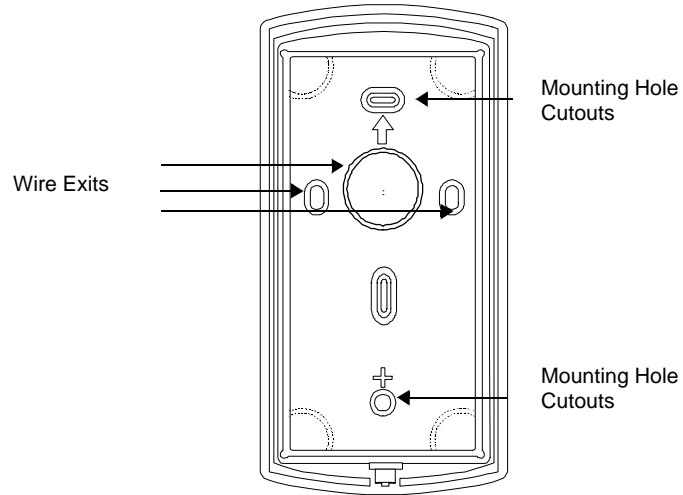
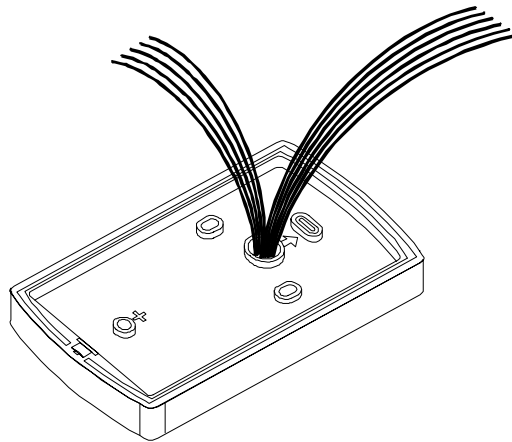

FIGURE 3: PULLING THE WIRES THROUGH THE BACKPLATE



HID CORPORATION

WIRING THE CONTROLLER KEYPAD FOR A STANDARD INSTALLATION

In a standard installation, the antenna housing remains installed in the controller keypad, and the complete unit is installed outside of the secured area. This is appropriate for interior doors or “low-risk” exterior installations.

For compliance with the UL294 Standard, additional installation requirements must be met – see page 14.

To wire the EntryProx unit for a standard installation, refer to Figure 4 and follow these instructions.

1. Touch a grounded object **BEFORE** touching the main circuit board to guard against possible static discharges.
2. Remove the main circuit board by pushing outward on the two spring tabs in the direction shown in Figure 4.
3. Lift the main circuit board.
4. Make the wiring connections for the door locking devices, the power supply, and the alarm inputs and outputs. Refer to the “Wiring EntryProx” section for appropriate wiring diagrams.
5. Reattach the main circuit board to the controller keypad unit.
6. Attach the controller keypad unit to the mounted backplate and secure the EntryProx unit with a hex screw or tamper screw.

Note: A ribbon cable holds the main circuit board to the controller keypad board. DO NOT CUT OR REMOVE this cable from its connector.

FIGURE 4: REMOVING THE CIRCUIT BOARD

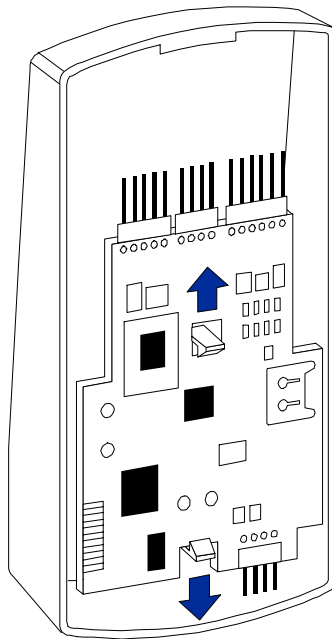

WIRING THE CONTROLLER KEYPAD FOR A SECURE INSTALLATION

In a secure installation, the waterproof antenna housing is removed from the controller keypad and mounted outside of a secured area. The control unit is installed inside the secured area. The blank filler piece is then inserted into the controller keypad in its place. **This is appropriate for exterior doors or “high-risk” locations.**

To wire the EntryProx unit for a secure installation, refer to Figures 5 and 6 and follow these instructions.

1. Touch a grounded object **BEFORE** touching the main circuit board to guard against possible static discharges.

2. Remove the main circuit board by pushing outward on the two spring tabs in the direction shown in Figure 4.
3. Lift the main circuit board.
4. Unplug the four-pin cable assembly from connector P4 on the main circuit board.
5. Release the antenna housing from the controller keypad by pressing inward on the four securing tabs.
6. Remove the antenna housing from the controller keypad by pushing forward as shown in Figure 6.
7. Insert the extra 10-inch antenna cable assembly into connector P4.
8. Splice in additional antenna cable Alpha 1174C (22AWG) up to a maximum of 10 feet.

Note: The Alpha 1174C antenna cable is not supplied with the EntryProx unit.

9. Make the wiring connections for the Request to Exit switch, the door locking devices, the power supply, and the alarm inputs and outputs. [Refer to the "Wiring EntryProx" section for appropriate wiring diagrams and instructions.](#)
10. Reattach the main circuit board to the controller keypad unit.
11. Insert the blank filler piece into the controller keypad unit.
12. Attach the controller keypad unit to the mounted backplate and secure the EntryProx unit with a hex screw or tamper screw.
13. Run the additional antenna cable to the antenna housing location.
14. Mount and wire the antenna housing

FIGURE 5: REMOVING THE P4 CONNECTOR

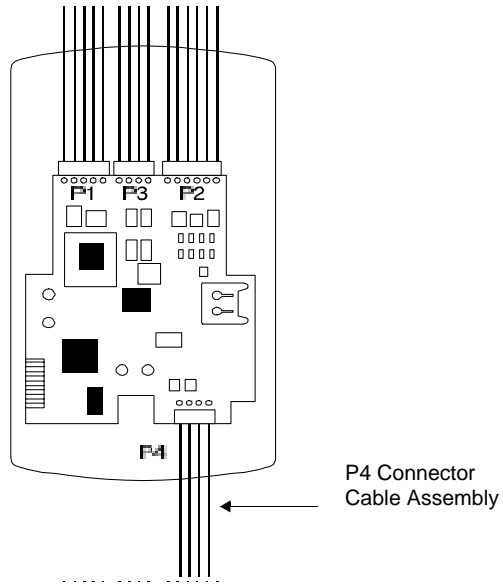

FIGURE 6: REMOVING THE ANTENNA HOUSING

MOUNTING AND WIRING THE ANTENNA HOUSING FOR A SECURE INSTALLATION

Mount and wire the antenna housing no more than 10 feet away from the controller keypad unit.

To mount and wire the antenna housing, refer to Figures 7 and 8 and follow these instructions.

1. Pull the additional antenna cable through the antenna housing's backplate cable holes.

FIGURE 7: MOUNTING THE ANTENNA BACKPLATE

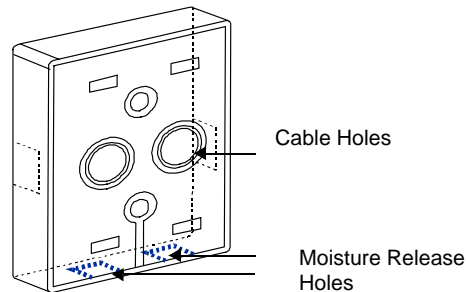

2. Position and secure the antenna backplate to the mounting surface so that the two moisture release holes are on the bottom.
3. Cut the plastic connector off the antenna cable assembly.
4. Splice in the additional antenna cable. Be careful to match the wire colors to the proper pin connectors on the 10-inch antenna cable assembly.
5. Attach the antenna housing to the backplate by inserting the four securing tabs into the backplate.
6. Seal the wire holes with silicone.

SELECTING A FILLER OR REQUEST TO EXIT LABEL

The filler piece replaces the antenna housing on the controller keypad when you use the high security installation. If you do not plan to use the filler piece as a Request to Exit switch:

1. Insert the filler piece into the opening on the controller keypad.
2. Apply the blank label.

FIGURE 8: ATTACHING THE ANTENNA HOUSING

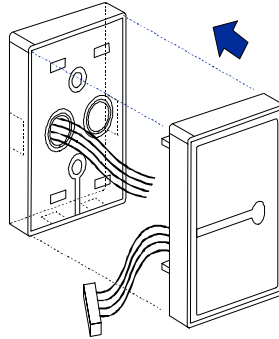

If you plan to use the filler piece as a Request to Exit switch:

1. Remove the two plastic side tabs on the filler piece.
2. Insert the silicone rubber cushion over the two alignment pins on the switch activator.
3. Apply the “Press to Exit” label to the filler piece.
4. Insert the filler piece into the opening on the controller keypad.
5. Refer to Figure 15 to make the wiring connections to the cable assembly if you are using a door contact.
6. Set the internal Request to Exit button ON, using programming Command 30, option 7 (see Table 2).

FIGURE 9: USING THE FILLER PIECE AS A REQUEST TO EXIT SWITCH

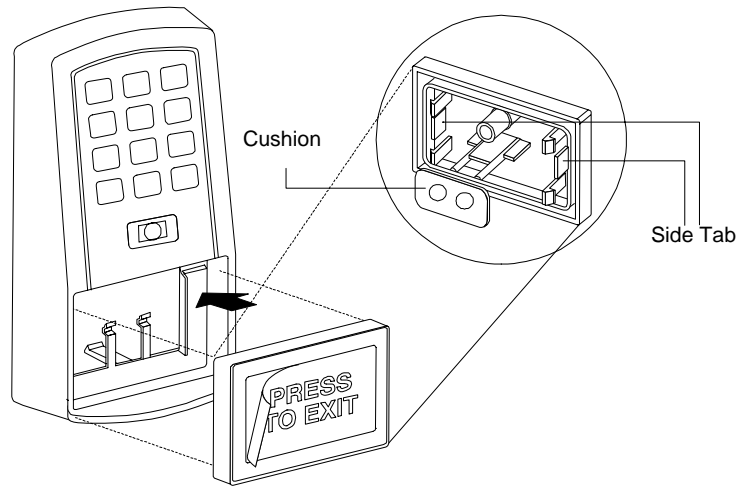

INSTALLATION REQUIREMENTS FOR UL 294 COMPLIANCE

The EntryProx Model 4045AGU00 complies with the UL294 Standard for access control units in a standard, wall-mount installation, when installed to the following specifications:

- Electric locking mechanisms may only be connected to the NO contacts of the Main Relay. Locking devices requiring an NC connection may only be used in conjunction with an interposing relay mounted inside the secure area and connected to the NO contacts of the Main Relay.
- The recommended or equivalent **shielded** wiring must be used for the following applications:

Request to Exit input cable	Alpha 1292C (22AWG) or 2421C (18AWG)
Wiegand data output cable	Alpha 1295C (22AWG)
Antenna cable extension	Alpha 1294C (22AWG)

The cable shield drain wires must be grounded at the reader end by connection to P1, Pin 4 (DC Power Ground) using appropriate wire nuts or crimp fittings.

- Tamper Switch must be installed in one of the configurations recommended below, and connected to an intrusion alarm system. (Refer to Figure 10 for switch/magnet locations)

MOUNTING OVER A METAL OR PLASTIC SINGLE GANG J-BOX

1. Use an Ademco 945T magnet and reed switch (or equivalent) with foam-backed adhesive tape.
2. Clip the screw mounting tabs from both the magnet and reed switch using pliers or a wire cutter.
3. Remove the backing sheet from the tape on the magnet and stick the magnet to the **plastic spacer**, which is factory-installed to the back of the Keypad board in location A (Figure 10).
4. Stick the reed switch on the inside of the long side of the J-box in the upper right-hand corner, using the adhesive tape. The switch should be flush with the edge of the J-box.

WALL MOUNTING

1. Use an Ademco PR-20451 magnet and reed switch (or equivalent) with foam-backed adhesive tape.
2. Remove the backing sheet from the tape on the magnet and stick the tape to the **plastic spacer**, which is factory-installed to the back of the Keypad board at location B (Figure 10).

HID CORPORATION

16

3. Drill a 3/8 inch hole in the wall behind the magnet location, feed the switch wire through the wall and press the switch into place.

FIGURE 10 – TAMPER SWITCH INSTALLATION

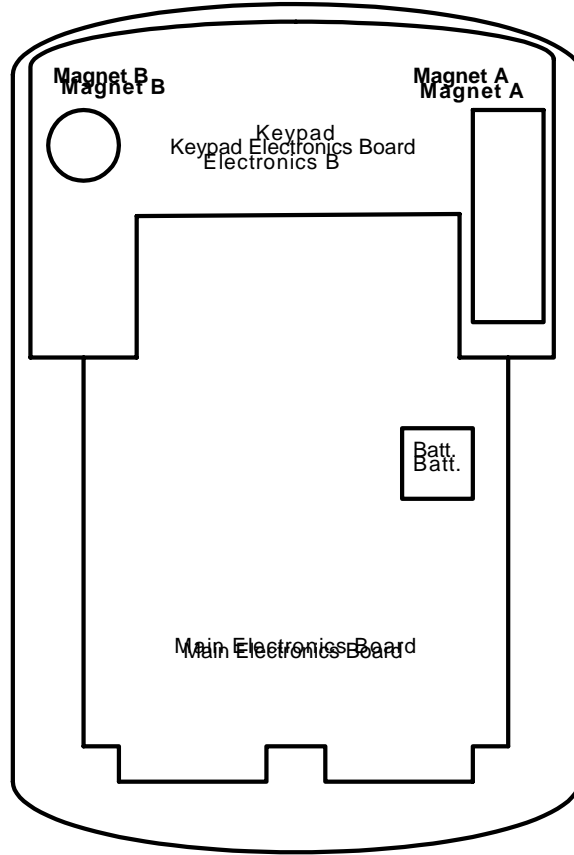

NOTE: UNIT IS SHOWN FROM BACK WITH BASE REMOVED

WIRING ENTRYPROX

This section includes wiring diagrams for the following:

- Wiring the main relay
- Wiring the auxiliary relay
- Wiring the Request to Exit switch

Figure 10 illustrates the location and description of the four pin connectors on the main circuit board and its use.

FIGURE 11: PIN LOCATOR DIAGRAM

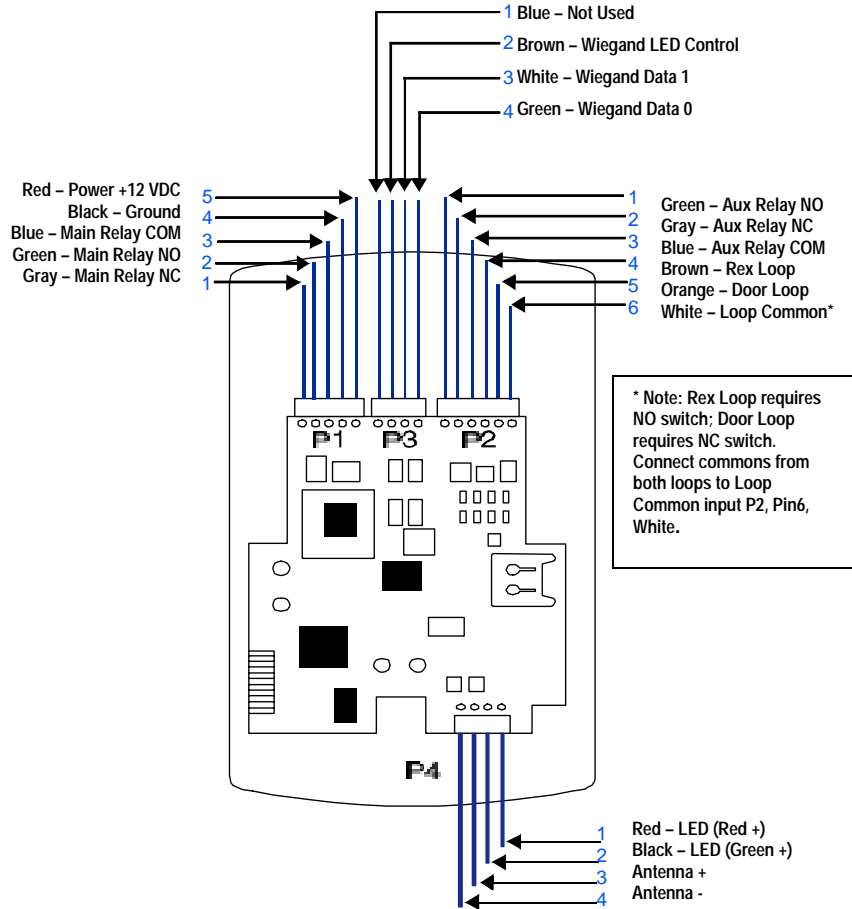

WIRING THE MAIN RELAY

The main relay for the door locking device is wired to connector P1 on the EntryProx main circuit board. To connect a Fail-Secure Strike or Lock see Figure 12. To connect a Maglock or Fail-Safe Strike see Figure 13.

WIRING A GATE ACTUATOR

You can make the wire connections for a gate actuator by connecting the Blue (C) wire and the Green (N/O) wire directly to the input as shown in Figure 12.

Note: DO NOT connect a power supply to the relay if you connect a gate actuator.

WIRING THE AUXILIARY RELAY

The EntryProx unit has an auxiliary relay feature that allows for customized alarm programming. Pins 1, 2, and 3 on the P2 connector can be wired for one of the following alarm outputs:

- Alarm shunt (see Figure 14)
- Forced or propped door (see Figure 15)

The alarm shunt operation allows you to use the auxiliary relay to bypass a door contact that is monitored by a separate alarm system. If the entry or exit is controlled by the EntryProx unit, an intrusion alarm will not be generated if the door is opened using an access card or PIN number, or by pressing the REX button.

The forced or propped door alarm allows you to use the auxiliary relay to provide a local warning, such as an audible or visual indicator if:

- A door is opened without using an access card or PIN number at the EntryProx unit.
- A door is legitimately opened but is held open too long.

Note: The auxiliary relay audible and visual indicators and the door open times can be programmed. Refer to *Table 2: Programming Commands* for more information.

FIGURE 12: ELECTRIC STRIKE (FAIL SECURE WIRING DIAGRAM)

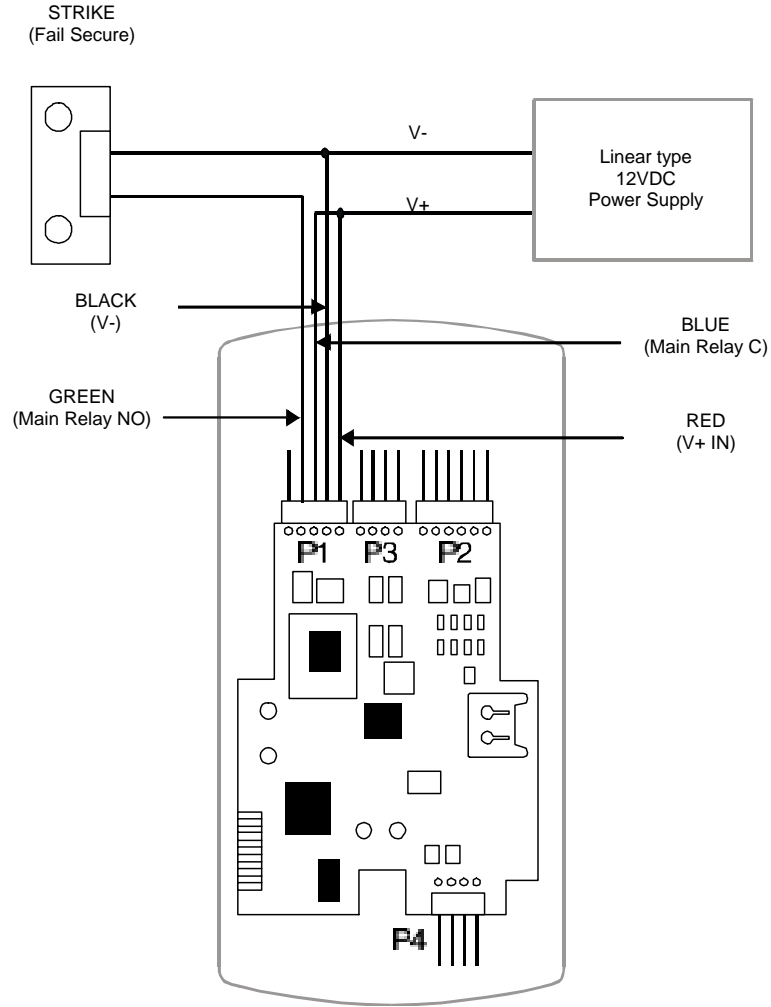

Strike can also be powered by a separate power supply; consult strike installation manual for details.

FIGURE 13: MAGLOCK (FAIL SAFE WIRING DIAGRAM)

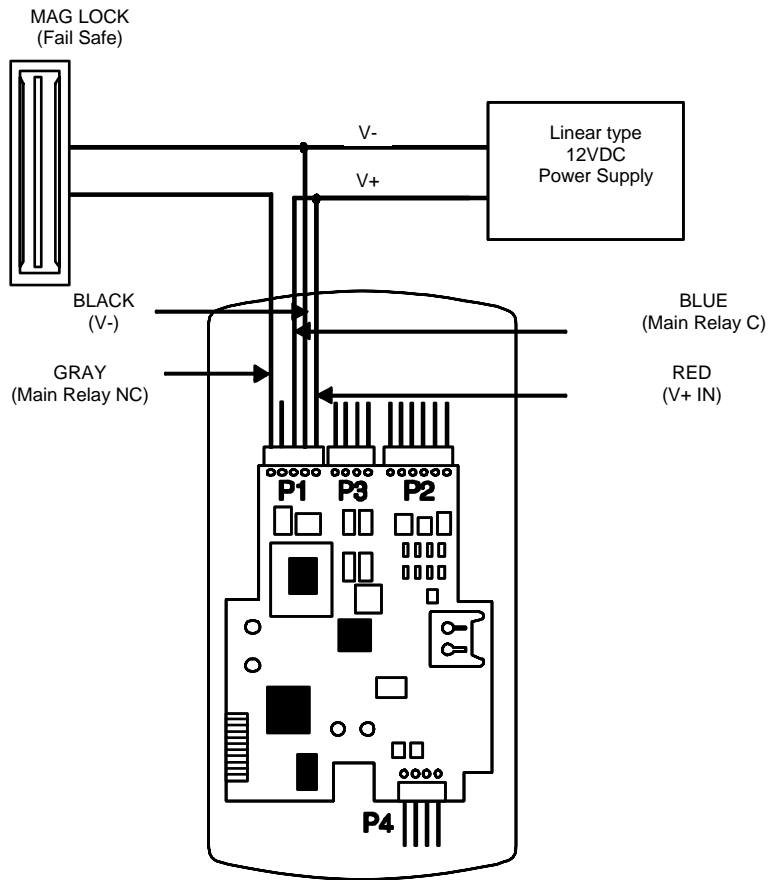

Mag Lock can also be powered by a separate power supply; consult Mag Lock installation manual for details.

FIGURE 14: WIRING AUXILIARY RELAY FOR ALARM SHUNT OPERATION

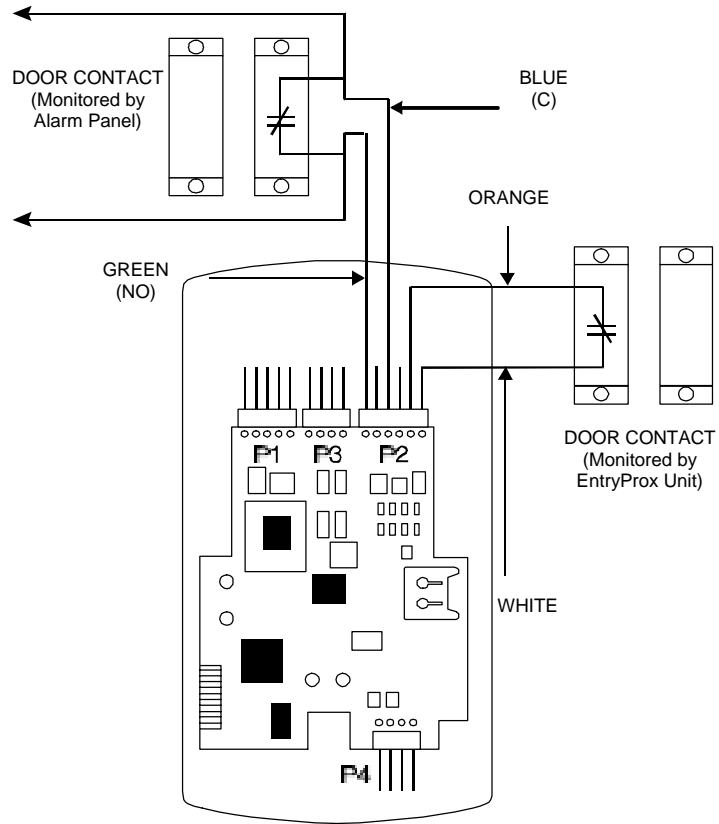
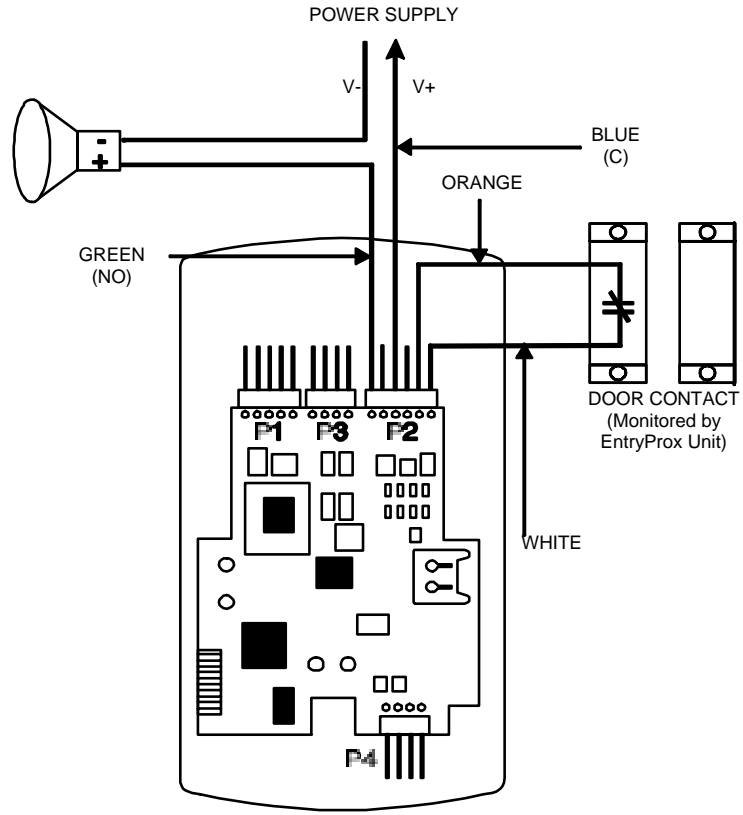

FIGURE 15: WIRING AUXILIARY RELAY FOR PROPPED/FORCED DOOR ALARM



WIRING THE REQUEST TO EXIT INPUT

When the EntryProx Request to Exit (REX) input receives a momentary switch closure, it engages the main relay for the programmed access time. It can be connected to a wall-mounted exit button, to a push button under a reception desk, or to the relay output of a passive infrared motion detector mounted above the door on the secure side. The Request to Exit input activates the alarm shunt to prevent false alarms when personnel use the controlled door to exit the secured area. The Transaction Log records all Request to Exit usages for monitoring purposes.

To wire the EntryProx Request to Exit input, refer to Figures 16 and 17.

Locate connector P2 on the main circuit board and remove the 2-pin jumper installed on pins 5 and 6.

Refer to Figure 17 to make the wiring connections to the cable assembly if you are **NOT** using a door contact

Note: If you do not use a door contact, you need to twist the white and orange wires together or the REX input will not function.

Note: The door contact *must* be closed for the Request to Exit feature to work properly

FIGURE 16: WIRING REQUEST TO EXIT INPUT (WITH DOOR CONTACT)

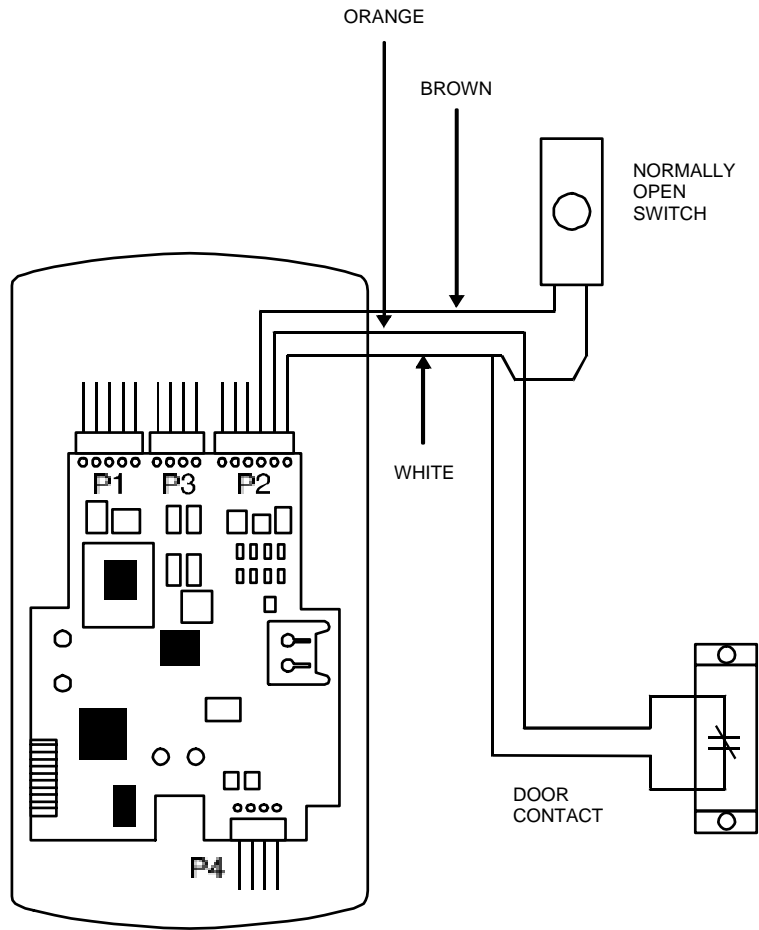
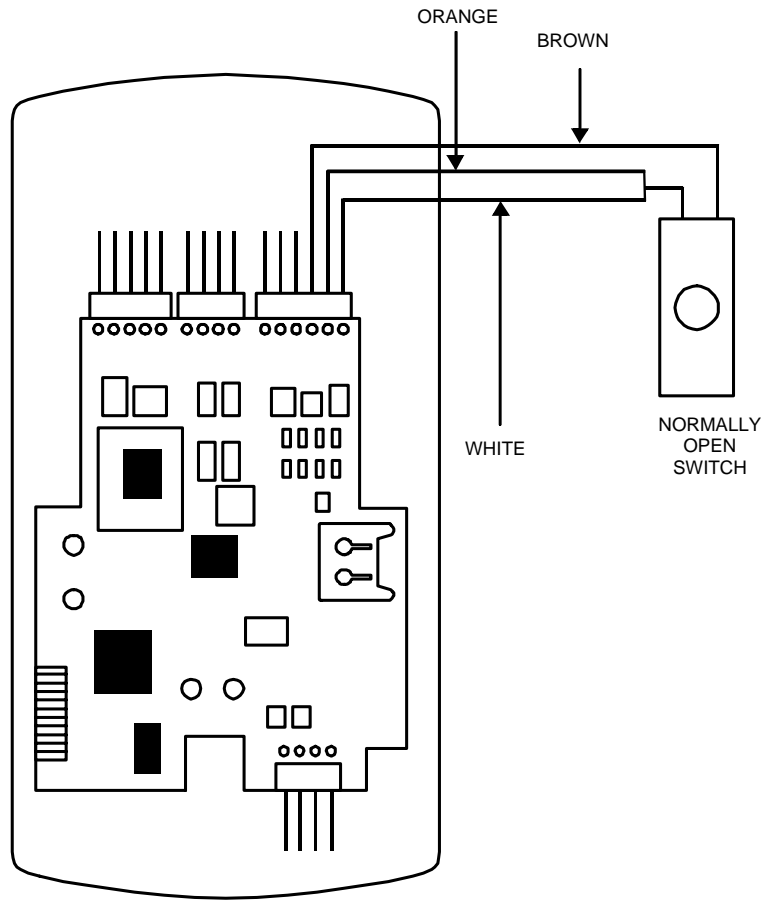

FIGURE 17: WIRING REQUEST TO EXIT INPUT (NO DOOR CONTACT)



PROGRAMMING ENTRYPROX**IMPORTANT – READ BEFORE
PROGRAMMING THE ENTRYPROX UNIT**

YOU MUST KEEP A USER LIST when programming cards and PIN codes into your EntryProx. Write down the User Location, Card Number, PIN Code and the Name of the User. Use the blank form at the end of this book as a photocopy master. You will need this information if you need to delete a card or PIN at a later time.

DO NOT PROGRAM A CARD OR PIN IN USER LOCATION 1 for normal access control use! User Location 1 is reserved for the MASTER CODE, which places the unit into programming mode.

CHANGE THE MASTER CODE from the factory default, after initial programming, and write this code down and keep it in a safe place.

IF YOU LOSE OR FORGET THE MASTER CODE:

End Users: contact your dealer –a service call is required.
Dealers: call HID for the procedure – and remember to bring the proper hex key or security tool to the customer site!

PROGRAMMING COMMAND SEQUENCES

Command sequences are simply a series of keypad entries to add cards and PINs or change operating characteristics of the EntryProx unit. There are three basic steps to programming EntryProx, using the Keypad on the control unit:

1-Place the unit in programming mode

press **99 # Master Code ***

2- Enter a Command Sequence

press a 2-digit command number to enter cards/PINs or specify parameters by pressing keys in various sequences

3- Exit programming mode - press * to exit.

LED INDICATION DURING PROGRAM MODE

A slow blinking yellow LED indicates that the unit is in program mode.

When the yellow LED stops blinking and is OFF completely, the unit is no longer in program mode.

A steady yellow LED indicates an error condition:

- 1- you are trying to enter a card or PIN which is already stored in another User Location
- 2- you have pressed the wrong key in a command sequence

Press * to clear the error condition and then enter a new code or PIN, or re-enter the command sequence as required. If the unit does not go into program mode, contact your dealer or HID Technical Support.

BEFORE YOU START...

Before programming cards, try to determine:

- **How many cards do I have to enroll?** If you have more than 25 you may want to batch enroll them. If you have fewer, you may want to program one at a time.

- **How are the cards encoded: What is the bit format, ID numbers and facility code?** If you have sequentially numbered cards with 26-bit format and the same facility code, you can batch-enroll them from the keypad. Otherwise you must program them individually or batch-enroll by sequentially placing the cards in front of the reader. **Note that if you choose to add new cards manually (via the keypad), the facility code must be entered into the unit first. For the programming sequence used to enter the 3-digit facility code, see Table 2, item 32.**

PIN CODE/CARD PROGRAMMING BASICS

PIN codes and card numbers can be programmed manually via the keypad. Cards can also be programmed by presentation to the reader at the correct point in the command sequence.

When adding or modifying PIN codes or cards the user enters a 2-digit Command, then specifies three or four data values: **a user type, a location and a keypad-PIN, and/or card.**

USER LOCATIONS

These are the locations in the unit's memory where Card and/or PIN User data is stored. EntryProx User Locations are numbered 1 – 2000. User Location 1 is reserved for the Master Code, used for programming – **Do not enter cards or PINs for normal access into User Location 1.**

USER TYPES

User Types determine what happens when a user presents their card/PIN to the reader. A User Location can be programmed as one of four specific user types:

Toggle/latch strike (0) For this user-type, when the Card is presented (or PIN is entered) the door opens for an indefinite period, until the card / code is reentered or another toggle code is entered (this is useful for deliveries, for example).

Normal access (1) This is the default user type, when the Card is presented (or PIN is entered) the door opens for the duration of the Main Relay time.

log Dump (2) For this user-type, when the Card is presented (or PIN is entered) the door remains locked and the Transaction Log is “dumped” to an optional IR printer

via the IR LED. (There are three LEDs on the top of the unit - the IR LED is the one on the right.) This code cannot be used to gain access through the door. Note that the log is only printed, not erased.

Lockout (3) For this user-type, the keypad “freezes,” disallowing all other codes, plus the door remains in the current state. During a lockout state, card access does not continue to work. If it is locked, it remains locked. If it is unlocked, it remains unlocked until another Lockout code is entered, releasing it from Lockout mode. **NOTE: Reserve this user-type for a supervisor or override function.**

PIN CODES, CARDS AND COMBINATIONS

A User Location can be programmed with one of the four PIN code/card combinations listed below using the programming Commands in parentheses

- (1) PIN Code ONLY (Command 50)
- (2) PIN Code AND Card (Command 50 plus present card to proximity reader)
- (3) Card ONLY (Command 50 or Command 51)
- (4) PIN Code OR Card (Command 52)

No User Location can have the same card and/or PIN code as another User Location.

ENTERING USER PIN CODES

EntryProx user PIN codes consist of a minimum of one digit and a maximum of six digits. Note that a leading “0” is considered a digit, and that the 5-digit code 12345 is different from the six-digit code 012345. Attempting to enter a user PIN code into memory that is already stored in a different user location causes the yellow LED to stop blinking and remain steadily lighted. If this occurs, try entering a different user code. Repeating digits in the same code is acceptable (ex: 121122).

HID CORPORATION

CARD/PIN PROGRAMMING SEQUENCES

Following are the most commonly used command sequences for programming user data into the EntryProx:

PROGRAMMING PIN + CARD

To program a user for both Code AND Card:

1. Place the EntryProx unit in program mode. Press:
99 # Master Code * (default is 1234)
2. On the EntryProx keypad, press:
**50 # user-type # user location # keypad PIN
* keypad PIN * <present card>**
3. Press * to exit program mode.

QUICK PROGRAMMING EITHER PINS OR CARDS

A “quick program” feature allows user data entry with minimal keystrokes. No command number is required. This feature programs either a card or a PIN, **not** a combination, and it automatically selects a “Normal” user access type. Just enter the user’s location and the PIN (or present card):

1. Place the EntryProx unit in program mode. Press:
99 # Master Code * (default is 1234)
2. On the EntryProx keypad, press:
**user location # PIN * PIN * OR
user location # ** <present card>**
3. Press * to exit program mode.

PROGRAMMING PIN CODE ONLY USE

To program PIN Code ONLY operation with Command 50 use the following program sequence:

1. Place the EntryProx unit in program mode. Press:
99 # Master Code * (default is 1234)
2. On the EntryProx keypad, press:
**50 # user-type # user location # keypad PIN
* keypad PIN ***
3. Press * to exit program mode.

USER TYPES - REMINDER

0-Toggle	1-Normal	2-Dump	3-Lockout
-----------------	-----------------	---------------	------------------

PROGRAMMING CARD ONLY USE

To program Card ONLY use with Command 50, simply omit the keypad PIN values from the sequence:

1. Place the EntryProx unit in program mode. Press:
99 # Master Code * (default is 1234)
2. On the EntryProx keypad, press:
50 # user-type # user location # **
<present card>
3. Press * to exit program mode.

PROGRAMMING CODE OR CARD

To program a user for either Code OR Card:

1. Place the EntryProx unit in program mode. Press:
99 # Master Code * (default is 1234)
2. On the EntryProx keypad, press:
52 # user-type # user location # keypad PIN
*** keypad PIN * <present card>**
3. Press * to exit program mode.

BATCH LOAD CARDS BY KEYPAD ENTRY

Command 56 allows you to batch load multiple, sequential 26-bit HID cards into the EntryProx unit. Up to 1,999 users can be added at one time. Cards need not be presented to the reader. Requirements are:

- Cards must all have the same facility code.
- Cards must be sequentially numbered
- The facility code must be programmed into the unit before any batch loading. See Table 2, Command 32 for the procedure. (This facility code cannot be changed at a later time).

Cards with multiple facility codes or many numbering gaps must be entered by presentation to the reader, using Command 53.

USER TYPES - REMINDER

0-Toggle	1-Normal	2-Dump	3-Lockout
-----------------	-----------------	---------------	------------------

If the Batch Loading conditions can be met:

1. Place the EntryProx unit in program mode. Press:
99 # Master Code * (default is 1234)
2. On the EntryProx keypad, press:
56 # (total number of cards to be added) #
(starting user location) # card number *
repeat card number *
NOTE: Never enter one (1) as the starting user location since it is reserved for the master code.
3. Press * to exit program mode.

BATCH LOAD BY PRESENTATION

Use Command 53 to program a batch of cards into consecutive User Locations by specify the starting User Location, then presenting cards or tags to the reader. Use any card format up to 37 bits. All cards are programmed alike and users are “card only.” Card enrollment stops once the current user location exceeds 2000, or press any key to abort. Keep a written record as you program cards.

Existing data in the User Locations being programmed is overwritten, unless you present a card that is already programmed into the EntryProx, in which case an error is generated. To clear the error, press the * key; then continue presenting cards. If you enter User Location 1 as the first card in the sequence, this will generate an error.

To batch load by presentation, follow this procedure:

1. Place the EntryProx unit in program mode. Press:
99 # Master Code * (default is 1234)
2. On the EntryProx keypad, press:
53 # user type # start location # ** <present
card> <present card>
<present card>...
3. Press * to exit program mode.

USER TYPES - REMINDER			
0-Toggle	1-Normal	2-Dump	3-Lockout

DELETING USERS

To delete a user from the EntryProx, you must know the User Location in which the information is stored.

1. Place the EntryProx unit in program mode. Press:
99 # Master Code * (default is 1234)
2. On the EntryProx keypad, press:
user location #**
3. Press * to exit program mode.

BLOCK DELETE USERS

Use Command 58 to delete all cards / PINs in a block of User Locations. The yellow LED will blink rapidly during the deletion process. It can take several seconds to delete large blocks of users. The following items will generate a programming error:

- Entering a starting User Location of 1 or greater than 2000
- Entering a total number of locations which exceeds 1999
- Entering a starting user location and number of locations which exceeds 2000

To block delete user locations, follow these steps:

1. Place the EntryProx unit in program mode. Press:
99 # Master Code * (default is 1234)
2. On the EntryProx keypad, press:
58 # start location # start location # number of locations * number of locations*
3. Press * to exit program mode

CHANGING THE MASTER CODE

Use the Quick Program Feature to change the master code

1. Place the EntryProx unit in program mode. Press:
99 # Master Code * (default is 1234)
2. On the EntryProx keypad, press:
1 # (new code) * (repeat new code) *
3. Press * to exit program mode

HID CORPORATION

CHANGING OPERATING PARAMETERS

Many users will use the EntryProx with the factory default operating parameters. The following commands include some of the most commonly customized parameters. For further refinements on EntryProx operation, review the options shown in Table 2.

CHANGING THE MAIN RELAY TIME

The main relay time applies to all users 1-2000. The factory default main relay time is five (5) seconds. Main relay time can be set from one to ninety-nine seconds in one-second increments using Command 11.

1. Place the EntryProx unit in program mode. Press:
99 # Master Code * (default is 1234)
2. Enter the new main relay time, in seconds (from 1 to 99). For example, to enter 10 seconds, press:
11 # 10 # 0 # **
3. Press * to exit program mode.

INVALID PIN LOCKOUT

Command 30, Option 18 allows you to enable or disable the Invalid PIN Lockout (IPL) feature. This feature prevents unauthorized persons from gaining entry by guessing PIN codes or Master Codes. When a preset number of invalid entries is exceeded (set by using Command 32 – option 4, default is 5) the EntryProx will either trigger the Forced Door output, or the keypad will be disabled for a user-configurable time period (select the action, using Command 30, option 19, and then set lockout time by using Command 32 – 5).

The invalid PIN code count is reset to zero by any of the following:

- entering a valid keypad PIN
- presenting a programmed Prox card
- entering a valid [99 # Master code*] sequence
- the expiration of the keypad timer

The Invalid PIN Lockout function disables all keypad PIN entries with the exception of the [99 # Master Code*] sequence for the duration of the lockout.

To clear an active timed Invalid PIN Lockout:

- disconnect power to the system
- present a valid prox card programmed as “Card Only” or “Card OR Code”
- Enter the [99 # Master Code *] sequence

Note that if an invalid [99# Master Code*] is entered as part of the sequence to clear the IPL, a good [99# Master Code*] sequence will not cancel the current lockout.

RESETTING THE MASTER CODE AND SYSTEM DEFAULTS ONLY

Command 40 erases everything from the EntryProx memory **except** the user list and transaction log and restores the default settings. This is useful if the EntryProx unit has experienced programming problems, or if you wish to delete earlier programming.

1. Place the EntryProx unit in program mode. Press:
99 # Master Code * (default is 1234)
2. Press:
40 # 00000 # 00000 # **
3. Press * to exit program mode.

ERASING ENTIRE MEMORY / RESETTING SYSTEM DEFAULTS

Command 46 deletes everything from the EntryProx memory **including** the user list but not the transaction log and restores the default settings. This is used as a last resort if you need to erase a specific user and could not retrieve the Programmed User List.

1. Place the EntryProx unit in program mode. Press:
99 # Master Code * (default is 1234)
2. Press:
46 # 00000 # 00000 # **
3. Press * to exit program mode.

TURNING KEYPRESS AUDIBLE FEEDBACK ON/OFF

The Keypress Audible Feedback command enables the sounder to beep once for each key press. This feature provides an audible acknowledgment that a particular key was pressed hard enough for the unit to understand. The factory-shipped default setting is ON, but it can be toggled ON and OFF as desired using command 30.

1. Place the EntryProx unit in program mode. Press:
99 # Master Code * (default is 1234)
2. To enable this feature, press:
30 # 0 # 1 # **
3. To disable this feature, press:
30 # 0 # 0 # **
4. Press * to exit program mode.

TURNING KEYPRESS VISUAL FEEDBACK ON/OFF

The keypress visual feedback feature lights the LED once for each key press. This feature provides a visual acknowledgment that a particular key was pressed hard enough for the unit to understand. The factory-shipped default setting is ON, but it can be toggled ON and OFF as desired.

1. Place the EntryProx unit in program mode. Press:
99 # Master Code * (default is 1234)
2. To enable this feature, press:
30 # 1 # 1 # **
3. To disable this feature, press:
30 # 1 # 0 # **
4. Press * to exit program mode.

AUTO ENTRY ENABLE

This function is not recommended for use, as it lowers the overall security of the unit and affects programming sequences ending with the * key. It is set with the 30# command (Set/Clear Standard Options). It allows PIN entry without pressing the * key to enter. Leave this feature in the default mode, which is OFF.

USING THE PRINTING FEATURES

The EntryProx unit in conjunction with an optional IR (infrared) hand-held printer can print a Transaction Log and a Programmed User List via the IR LED. There are three LEDs on the top of the unit - the IR LED is the one on the right.

SELECTING TRANSACTION LOG INFORMATION

You can selectively program specific transaction events to print (or not) on the Transaction Log. By “masking” out certain events, you direct the unit not to save those events in memory and thus they do not appear in the log. The factory default is for all transaction events to be saved in memory and printed on the log. The procedure follows:

1. Place the EntryProx unit in program mode. Press:
99 # Master Code * (default is 1234)
2. To turn OFF an event (keep it from being stored/logged), enter:
73 # Event Code # 0 # **
To turn an event ON, enter:
73 # Event Code # 1 # **
3. Press * to exit program mode.

The Event Code is a two-digit number that represents a specific transaction as listed in the following table.

The following transaction events can be set/cleared (saved/not saved) and therefore printed/not printed.

HID CORPORATION

EVENT CODE	TRANSACTION EVENT
01	Access Denied
02	Program Denied
03	Program Mode
04	REX (Request to Exit)
05	Door Ajar
06	Door Closed
07	Forced Door
08	Log Erased
09	Facility Access
16	Print
17	Access
20	TGL ON (Toggle ON)
21	TGL OFF (Toggle OFF)
24	Lo ON (Lockout ON)
25	Lo OFF (Lockout OFF)
27	MSMTCH (Mismatch on Card and Code entry)

PRINTING A TRANSACTION LOG

If you have an optional IR printer, you can print a Transaction Log via the EntryProx's IR port. Transaction Logs can be printed using two different methods, (1) by programming a card or code to "dump" the transaction log to the printer, and (2) by placing the EntryProx unit into program mode and manually entering the Print Transaction Log command.

PROGRAMMING A CARD OR CODE TO INITIATE A TRANSACTION LOG REPORT "DUMP"

1. Place the EntryProx unit in program mode. Press:
99 # Master Code * (default is 1234)
2. For a **CODE DUMP**, press:
50 # 2 # user location # code * code *
For a **CARD DUMP**, press:
50 # 2 # user location # ** <present card>
and then present the card at the proximity reader.
3. Press ***** to exit program mode.

NOTE: Entering the programmed PIN code or presenting the card subsequently causes the unit to print a Transaction Log to the optional IR printer.

PRINTING A TRANSACTION LOG MANUALLY

1. Place the EntryProx unit in program mode. Press: **99 # Master Code *** (default is 1234)
2. Hold the optional IR printer up to the EntryProx IR port steadily (about one or two inches away; the IR port is located to the right of the yellow LED) and then press: **70 # 0 # 0 # ****
3. Press * to exit program mode.

The 70 command is logged in the transaction buffer (in memory), providing a reference as to when the log was printed. Figure 18 shows a sample Transaction Log.

FIGURE 18 - TRANSACTION LOG

05/04/99	
#	Time Action
1	20:32 User 0015 Print
2	20:23 User 0011 ACCESS
3	20:22 User 0011 ACCESS
4	20:22 REX
5	20:22 Forced Door
6	20:22 User 0011 ACCESS
7	20:21 Forced Door
8	20:21 User 0011 ACCESS
9	20:21 Forced Door
0	20:20 User 0002 ACCESS
1	20:20 User 0002 ACCESS
2	20:19 User 0002 ACCESS
3	20:19 User 0003 ACCESS
4	20:19 User 0004 LO OFF
5	20:19 User 0004 LO ON
6	20:19 User 0004 LO OFF
7	20:18 User 0004 LO ON
8	20:18 User 0006 TG OFF
9	20:18 User 0006 TG ON
0	20:18 User 0006 TG OFF
1	20:17 User 0005 Print
2	20:17 User 0006 TG ON
3	20:16 User 0008 ACCESS
4	20:16 User 0008 ACCESS
5	20:16 User 0011 ACCESS
6	20:11 User 0013 TG OFF
7	20:11 User 0013 TG ON
8	20:11 User 0012 LO OFF
9	20:11 User 0012 LO ON
0	20:11 User 0012 LO OFF
1	20:09 User 0012 LO ON
2	20:09 User 0013 TG OFF
3	20:09 User 0012 LO OFF
4	20:09 User 0012 LO ON
5	20:09 User 0013 TG ON
6	20:09 User 0013 TG OFF
7	20:09 User 0013 TG ON
8	20:09 User 0013 TG OFF

Here is a description of the the report layout:

Top line - DATE.

Second line – column headings

- event line number, increments 1 to (1)0
and repeats.

TIME - 24-hour format.

ACTION describes each event, the user location and
type of action

ERASING A TRANSACTION LOG

The Transaction Log should be erased from memory
after being printed to prevent conflicting logs. To
erase the log, enter the following sequence:

1. Place the EntryProx unit in program mode. Press:
99 # Master Code * (default is 1234)]
2. To erase the transaction log press:
76 # 00000 # 00000 # **
3. Press * to exit program mode.

PRINTING A PROGRAMMED USERS LIST

The Programmed Users List can be printed to the optional IR
printer

via the unit's IR port. The printed list identifies the user
location for each

user's data. It does not print user locations that are not
programmed.

1. Place the EntryProx unit in program mode. Press:
99 # Master Code * (default is 1234)]
2. Hold the optional IR printer up to the EntryProx
IR port steadily (about one or two inches away;
the IR port is located to the right of the yellow
LED) and then press:
25 # 0 # 0 # **
3. When the list is complete, press * to exit program
mode. To maintain a more detailed record,
simply write down each user's name beside the

corresponding line number.

HID CORPORATION

FIGURE 19 - PROGRAMMED USER LIST

Door #0001-----			
Programmed Users			
0001	SN	1256	
0002	BT	147	011/06789
0003	BN	2500	011/06788
0004	BD	369	011/06794
0005	BL	789	011/06790
0008	EN	456	011/06792
0011	SN	987	

Here is a description of the Report Layout:

Top line – DOOR NUMBER.

Second line - TITLE

Column 1 – User location

Column 2 – user type (see table)

First letter – access modes		Second letter – user types	
S	Single PIN	T	Toggle function
B	Both code and card	N	Normal User
E	Either code or card	D	Print Reports (dump)
		L	Lockout

Column 3 – PIN CODE

Column 3 - SITE CODE/CARD NUMBER.

WIEGAND MODE

If you program the EntryProx unit to operate in Wiegand mode with a separate access control panel, the following features are not accessible:

- The EntryProx unit does not control door lock or unlocking operations.
- The EntryProx unit is not able to store codes in memory.
- The main and auxiliary relay functions are turned off.
- The door monitor and Request to Exit inputs are disabled.

For more information on programming the EntryProx unit for Wiegand operation, please contact your local distributor.

PIN CODE OUTPUT IN WIEGAND MODE

The system transmits keypad PINs while operating in Wiegand mode by processing any digit sequence terminated with the [*] key as 26-bit Wiegand data. The current facility code (set using Code 32 - 2) will be used. Entering any PIN over 65535 will cause an error condition and no data will be sent.

Because keypad data is sent in a card data format, it may not be possible for some panels to perform CARD AND CODE operation (requiring both) to gain access. If your panel cannot accept and interpret 26-bit format as PIN data, be sure to configure the user at the PC host software by entering the code into the CARD data field for that user, not the keypad PIN number field.

PROGRAMMING COMMAND TABLE

Read the following table before completing programming of your EntryProx unit; it describes various programming commands and how to execute them. As with the previously described commands, you must first press **99 # (Master Code) *** to enter programming mode, enter the desired command sequence, and then press * to exit programming mode. “Ref” number is for reference only, not to provide an ordered sequence of commands.

TABLE 2: PROGRAMMING COMMANDS.

Ref	IF YOU WANT TO	PRESS	DETAILS
1	Enter program mode	99 # (Master Code) *	yellow LED blinks slowly
2	Change master code Code-only operations	1 # (new code) * (repeat code) *	example; 4321 master code (1 # 4321 * 4321 *)
3	Set main relay time	11 # tt # 0 # **	tt = 1 - 99 seconds
4	Set AUX relay output	15 # output mode # 0 # **	Output Modes: 0 = disabled, 1 = shunt , 2 = forced door, 3 = propped door
5	Delete users	User Location # **	Example: To delete user 100, press: 100#**
6	Print a transaction Log	70 # 0 # 0 # **	Hold optional printer with IR receiver near the EntryProx IR LED.

Ref	IF YOU WANT TO	PRESS	DETAILS
7	Set/clear standard option	30 # option # s/c # **	See below for Option numbers and descriptions

Option Number/Description	Set/Clear
0: Audio keypress feature	0 = OFF/1 = ON
1: Visual keypress feature	0 = OFF/1 = ON
2: Auto entry enable	0 = OFF/1 = ON (Recommend OFF)
3: Stand-alone/Wiegand operation	0 = standalone /1=Wiegand
4: Facility code access (26-bit cards only)	0 = OFF/1 = ON
5: Forced door audio alert	0 = OFF/ 1 = ON
6: Propped door audio alert	0 = OFF/1 = ON
7: Internal Request to Exit switch	0 = OFF/1 = ON
8: US/EU date format	0 = US/1 = European
9: Wiegand red LED enable	0 = OFF/1 = ON
10: Wiegand red LED active state	0 = LOW/1 = HIGH
11: Wiegand green LED enable	0 = OFF/ 1 = ON
12: Wiegand green LED active	0 = LOW/1 = HIGH
13: Daylight saving time	0 = OFF/ 1 = ON
14: Prox card antipassback select	0 = OFF / 1= ON (prevents multiple card reads in Wiegand mode)
18: Invalid PIN lockout select	0 = OFF / 1= ON
19: Invalid PIN lockout action	0 = TIMED LOCKOUT / 1 = Forced Door Output

Ref	IF YOU WANT TO	PRESS	DETAILS
8	Print programmed user list	25 # 0 # 0# **	Hold optional printer with IR receiver near the EntryProx IR LED.
9	Print programmed user list (starting at a certain user)	25 # 0 # start user # **	Hold optional printer with IR receiver near the EntryProx IR LED.
10	Change Wiegand parameters	32 # parameter # value # **	<p>Parameter/Value</p> <p>0, Wiegand pulse count/1- 255 (8 - 160µs)</p> <p>1, Wiegand interpulse/1-255 (spacing 32 - 640µs)</p> <p>2, facility code/0-225 (default = 0) (26-bit cards only)</p> <p>3, Process card timer 2 – 240 in ¼ second increments, defaults to 4 – 1 second. (If Option 30# 14# is enabled, this sets the time that a card must be removed from the RF field before it can be re-read.)</p> <p>4, Invalid PIN lockout threshold 1 – 50 attempts (defaults to 5)</p> <p>5, Invalid PIN lockout duration 1 – 255 in 5 second increments (defaults to 60 - 5 minutes)</p>

Ref	IF YOU WANT TO	PRESS	DETAILS
11	Set system time	41 # hhmm # 0 # **	hhmm = hour/minute, 24-hr format
12	Set system date	42 # mmddy # dow # **	mmddy = month, day, year; dow = day of week, 1 = Sunday
13	Set door number	43 # nnnn # 0 # **	nnnn = door number (for printed reports)
14	Set propped door time (this sets delay time for both the Aux Relay and local sounder)	44 # ttt # 0 # **	ttt = propped door time, to nearest 10's seconds, entered as 10 -990; default = 30 seconds
15	Set forced door time (this sets active time for both the Aux Relay and local sounder)	45 # ttt # 0 # **	ttt = forced door time, to nearest 10's seconds, entered as 10 - 990; default = 10 seconds
16	Delete memory except user list and restore system defaults (also see command 46)	40 # 00000 # 00000 # **	
17	Delete all memory and reset system defaults	46 # 00000 # 00000 # **	

Ref	IF YOU WANT TO	PRESS	DETAILS
18	Program user: Code ONLY <i>NOTE: You can program the four types of users shown to the right</i>	50 # user-type # user location # code * repeat code *	User Types: 0 - Toggle/latch strike 1 - Normal Access 2 - Log Dump 3 - Lockout
19	Program user: Code AND Card	50 # user-type # user location # code * repeat code * <present card>	
20	Program user: Card ONLY	50 # user-type # user location # * * <present card>	
21	Program card user manually: Card ONLY (26-bit cards ONLY)	51 # user-type # user location # card ID * card ID *	the card ID appears on the card (facility code must be entered first; see 32 # 2 # command)
22	Program user: Code OR Card	52 # user-type # user location # code* repeat code * <present card>	
23	Program a group of consecutive users by presenting cards	53 # user type # start location # ** <present card> <present card> <present card> ...	Programs card-only users. Stops at user location 2000, or press any key to abort. Erases existing programming. If an existing card is presented, an error will occur – press * to resume

Ref	IF YOU WANT TO	PRESS	DETAILS
24	Perform batch entry of users: Card ONLY (26-bit cards ONLY)	56 # total count # starting user location # starting card ID * starting card ID *	the card ID appears on the card; (facility code must be entered first; see 32 # 2 # command)
25	Block Delete Users	58 # start user # start user # number of users * number of users *	Yellow LED blinks rapidly; allow several seconds for large blocks of users. Cannot delete: master user, more than 1999 users, or user location greater than 2000.
26	Quick Enroll Card	User Location # * * <present card>	
27	Print Transaction Log via IR port	70 # 0 # 0 # **	Hold optional printer with IR receiver near the EntryProx IR LED.
28	Set transaction log mask (set/clear event logging)	73 # event # set/ clear # **	Prevent specified transactions from being logged. Set = 1 (prevent) Clear = 2 (restore) See list below.

		Code – Transaction Event	
		01 – Access Denied 02 – Program Denied 03 – Program Mode 04 – Request to Exit 05 – Door Ajar 06 – Door Closed 07 – Forced Door 08 – Log Erased 09 – Facility Access 16 – Print 17 – Access 20 – Toggle ON 21 – Toggle OFF 24 – Lockout ON 25 – Lockout OFF 27 – Mismatch	
	IF YOU WANT TO	PRESS	DETAILS
29	Reset transaction Log	76 # 00000 # 00000 # **	
30	To exit Program mode	* (after final command)	yellow LED stops flashing

LED/SOUNDER STATUS INDICATIONS

TABLE 3 – LED/SOUNDER INDICATIONS

LED OR SOUNDER	VISUAL/AUDIBLE CONDITION	DESCRIPTION
Yellow LED	Slow blink	Unit is in Program mode
	Rapid blink	Verify mode is active (checking that the last two values in sequence match)
	Steady	Program error; to clear, press *
	Very rapid blink	Memory (EEPROM) erase is in progress (commands 40/46, 58 loop-back)
Bi-Color LED	Steady red	Strike is locked
	Steady green	Strike is energized (timed or latched)
	Solid green with red flicker	Strike toggle is unlocked and user lockout active
	Red/green alternating	Awaiting second form of ID during “Card AND Code” access attempt
	Red blink	User lockout is active and strike locked; red LED drops out for 100 ms every second; normal users cannot change the state of the relay. This also indicates Invalid Pin Lockout.

LED OR SOUNDER	VISUAL/AUDIBLE CONDITION	DESCRIPTION
Sounder	Short beep (100 ms) every 2 seconds	Propped door is active
	Sounder 1/2 second on, 1/2 second off	Forced door is active
	3 rapid beeps after code is entered or card is presented	Code or Card is not found
	3 slow beeps (250 ms), then a single beep	Self-test is complete
	1 single beep	Valid card access

