



# IQL165 Explosionproof floodlight

**6 years operational warranty**

**Maintenance free with 60.000 hours**

**ATEX Category 3**

**II 3 GD EEx nA II T3 160°C**

**Certified for use in  
Zone 2 and Zone 22**



Article number	Voltage	Wattage	Lens	Version	Weight
65226002	230/240 V	165 W	Toughened glass	With 8 metre cable	12Kg
65126002	110/120 V	165 W	Toughened glass	With 8 metre cable	12Kg

## Applications:

- Area lighting
- Loading docks
- Tunnel lighting
- Security lighting

## Characteristics:

- Luminaire is sealed for life
- Patented system is based on the induction principle
- High colour rendering RA>85
- High vibration resistance
- Standard voltage 230/240VAC/DC 50/60Hz
- Ambient temperature range -40°C to +40°C
- Immediate ignition and re-ignition
- Housing is made from corrosion resistant aluminium
- Ingress protection IP66
- Standard version supplied with 8 metre flying lead 3 x 2,5 mm<sup>2</sup> cable
- Toughened glass protection
- Special offshore paint treatment, polyurethane, RAL6003
- Including an adjustable stainless steel mounting bracket
- High Lumen/Wattage performance ratio: 72
- Compact light-weight construction

## Options:

- 110V/120AC and DC
- Industrial version

## Light distribution curve

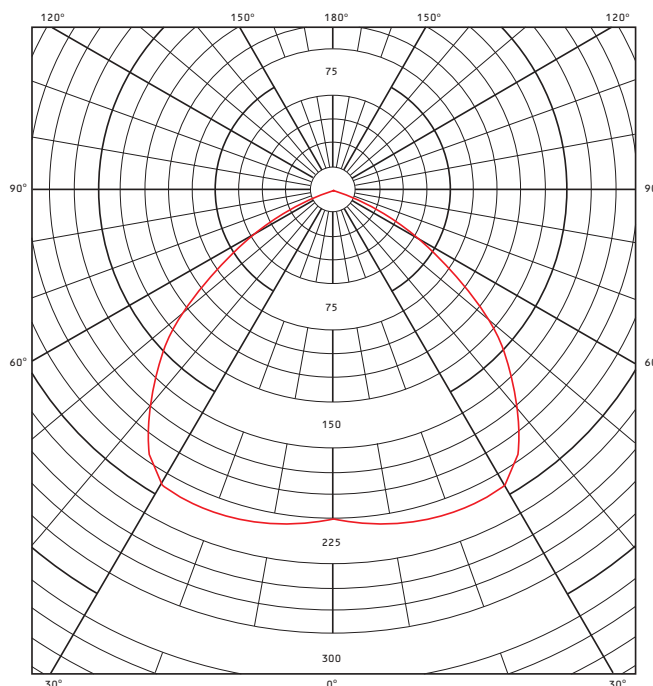

Light distribution curve per 1000 lumens

# IQL165 Explosionproof floodlight

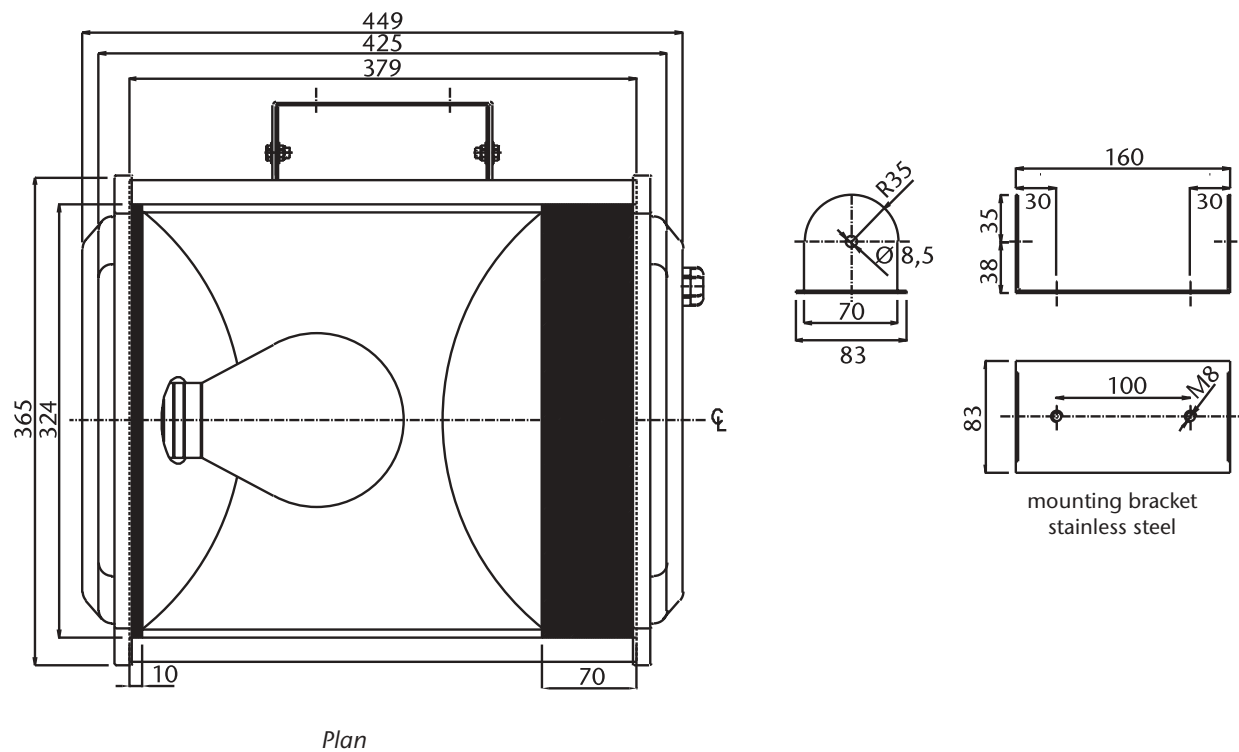
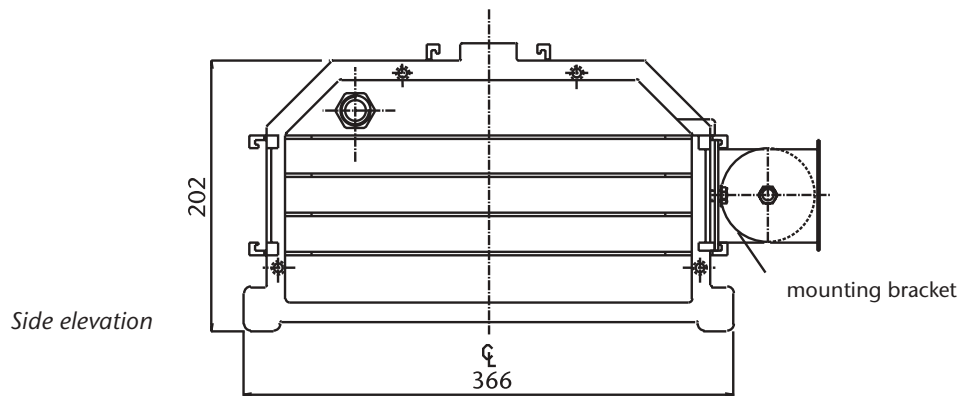
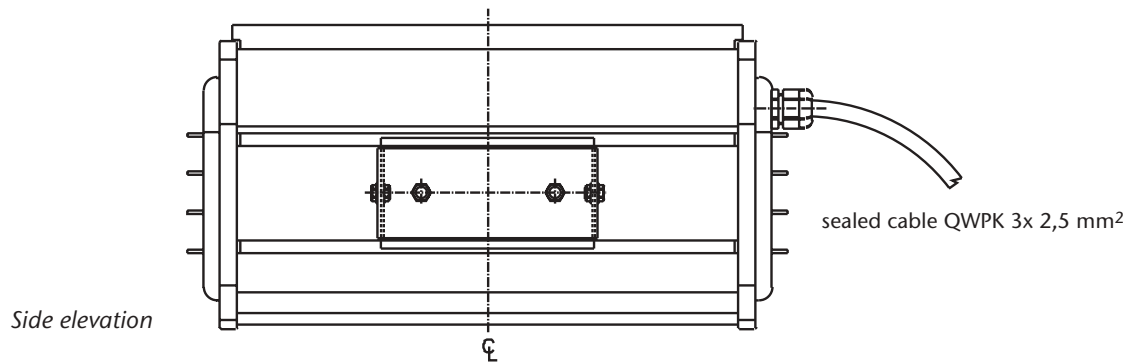

This document replaces all previous issues  
May be subject to modifications, 05 - IMT 19 - 12/03