

Securitex Industrial Detection Division

Securitex Flammable Gas Detector

The ND-104N LPG and NG gas detector was manufactured by Shin Woo. This gas detector are widely use in commercial kitchen, factory canteen, vessel kitchen and also in home kitchen etc. The ND-104N can detect even a small leakage of gas and the designed make it very easy to install and blend in with most kitchen deco. The ND-104N was also designed to take a certain amount of water splash as such is suitable to install in area which is damp.

Model: ND-104N



Feature

- Easy to install
- Compact and Simple design
- Install on the wall in Kitchen or Boiler Room
- LP Gas, Natural Gas, Propane and Butane (Can be detected)

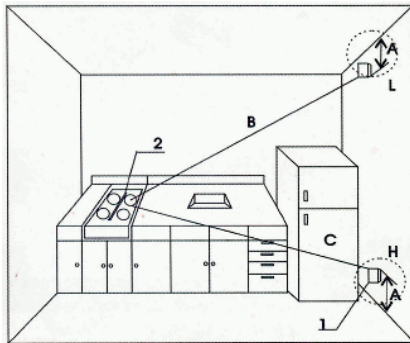

How to install

1. Gas detector
2. Gas range

- A: Install within 30cm
 B: Locate within 6 meter
 C: Locate within 4 meter
 L: In case of lighter gas than Air-Natural Gas and Methane
 H: In case of heavier gas than Air-LP Gas, Propane and Butane

The unit is to be install within 30cm from the bottom if you use heavy gas such as LPG, propane and 30cm from ceiling if you use light gas such as LNG, methane and the detector is to be located and install 5m from gas appliance

System Specification			
Model	ND-104N	Weight	240g
Type	Standalone Alarm	Application	Kitchen, Apartment, Office, School and factory canteen. Restaurant Kitchen and LPG storage room
Sensing Method	Catalytic bead	Operating temp	-20 ~+50 degree Celsius
Power Voltage	AC220V 50Hz, 1.3W	Operating Humidity	0 to 90% RH
Output power	NIL	Power lamp	Green Colour
Detection range	LP gas, Natural Gas 0-100%	Visual Alarm	Flashing Red LED light
Detectable gas	LPG, NG, Propane, Methane and Butane	Audio Alarm	Intermittent alarm sound 70dB at 1m
Dimension	110(L) X 70(W) X 37(H)	Recovery time	Automatic Recovery
Case material	ABS plastic	Approval	CE Mark

Specialized in industrial security, safety and automation for refinery, oil & gas, aviation and marine facilities