

GD-830F (Floor Mount)

Input Voltage: 12(or24)Vdc
 Current Draw: 65mA@12Vdc
 60mA@24Vdc
 Cutout Switch
 Holding Force: 70 lbs
 Finish: Black Powder Coated



GD-830S

Wall Surface Mount
 Input Voltage: 12(or24)Vdc
 Current Draw: 65mA@12Vdc
 60mA@24Vdc
 Holding Force: 70 lbs

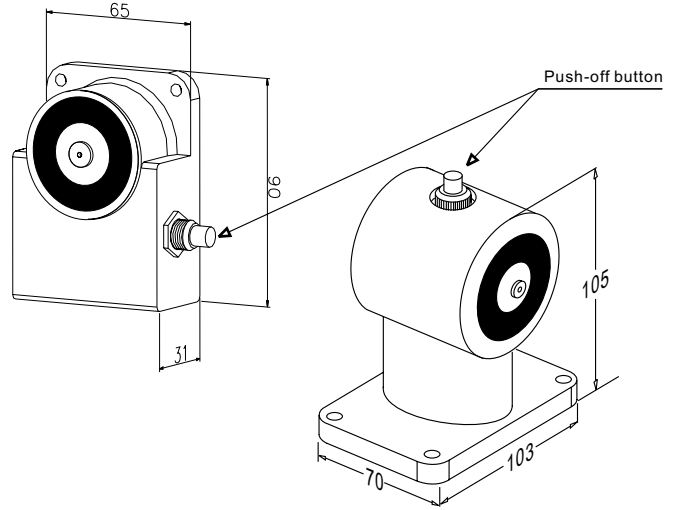

Unit: mm

Application :

Specifications:

The GD-830 series door holder is a fail-safe unit energized by a power supply installed on large-scale building, between fire escape doors. It releases the armature plate allowing the door closer to close the door when the fire prevention system detects a fire alarm or emergency. The electromagnetic door holder are constructed with a PUSH OFF button on magnet for instant release, the door can be open or close manually at any time.

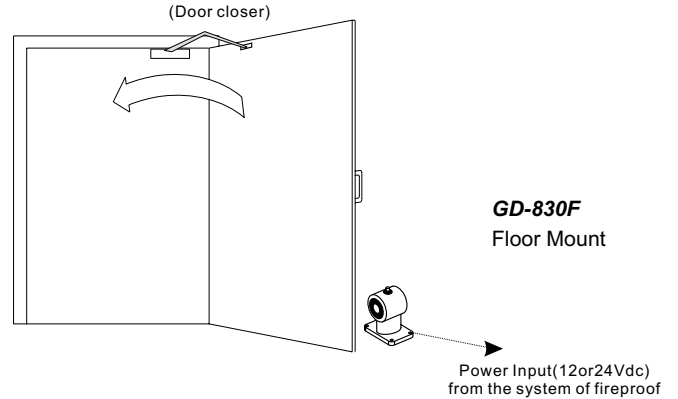

Warranty:

GEM access control related accessories are warranted against defects in material and workmanship while used in normal service for a period of 1 year from the date of sale to the original customer.

Disclaimer:

The information and specifications printed in this manual are current at the time of publication. The GEM policy is one of continual development and improvement; therefore GEM reserves the right to change specifications without notice.

