



[Color Hands-free Home Automation System]

KHV-446S / KHV-446T / KHV-446ST / KHV-456S / KHV-456T / KHV-456ST

KOCOM CO.,LTD.

This manual is based on the date as shown in the right and specifications are subject to change without notice for quality improvement.

Warranty



To receive after-sales service, have the following ready when you contact our branches

1. Name of the product
2. Model number of the product
3. The area of problem
4. Phone number and address at which you can be contacted.

Warranty Card

PRODUCT	
MODEL	
DATE PURCHASED	
WARRANTY PERIOD	
AGENCY ADDRESS	

☉ **KOCOM Warranties the original purchaser of this product as follows.**

- 1) This product is produced under strict quality control and inspection procedures.
- 2) If this product breaks down during proper use as a result of product defect, KOCOM will repair it within one year from date of purchase free of charge.
- 3) The following cases will be subject to charge, even during warranty period:
 - a. Breakdown during transport, or through careless treatment, by consumer.
 - b. Breakdown cause by unauthorized repair, or system modification.
 - c. Breakdown caused by natural disaster or power disorder.



"CAUTION: IT HAS POSSIBILITY TO HAPPEN INOPERABLE, AS THIS PRODUCT EXPOSED TO ELECTRON WAVE"

Product	Model No.	Size of Colored LCD	Front Door, Guardroom, Common Front Door, Emergency, Security1 & 2	Fire & Gas Leakage prevention	900MHz Wireless Communication Telephone	Telephone
HomeAuto	KHV-446S	4"	●	●		●
	KHV-446 T	4"	●			●
	KHV-446ST	4"	●	●	●	●
	KHV-456S	5"	●	●		●
	KHV-456 T	5"	●			●
	KHV-456ST	5"	●	●	●	●

- This specification is only applied to the products that are noted in round brackets of functional specifications in user's manual.
- KOCOM's Home Auto Products are manufactured through strict quality control and testing procedures.
- For right use in more convenient and easier ways, read this user's manual and the attached safety instructions carefully before using the products.

Contents

1. Safety Instructions	2
2. Product Features / Warnings	8
3. Components / Product Configuration	9
4. Name of Each Part	10
5. Overall Wiring Diagram	12
6. Main Body Installation	14
7. Camera Installation	15
8. Warnings in Installation	16
9. Self-alarming Test	17
10. Adjusting the Video Display and Call Sign Volume	18
11. Communication with Front Door	19
12. Automatic Open/Close of Front Door	20
13. Communication with Guardroom	21
14. Operation in Call during the Communication	22
15. Priority Communication	22
16. Common Gate camera Detouring Communication	23
17. Telephone Call	23
18. Security and Accident Prevention	24
19. Interlocked Communication with 900MHz Wireless Telephone	29
20. Direct Communication using Wireless Telephone	30
21. Read Before Requesting the Repairing Works...	
22. Quality Warranty	





Cautions for Safety

For safe use, please stick to the following cautions.



- Read this cautions carefully and keep it within easy reach of you.
- For right installation, read this cautions thoroughly. Please install the product according to its specifications.
- This Cautions for Safety may include items that are not contained in specifications of the product that consumer purchases.
- Reading this cautions, use the product in a right manner. For further information, please contact our A/S center.

About Symbol

A variety of symbols are used in this Cautions for Safety and your products to guide you to use products in a right and safe manner and to prevent possible risks for users and other persons and damages to their property. The meaning of each symbol is as follows. After fully aware of meaning of each symbol, read the following cautions.

	Warnings	This symbol means that wrong handling or ignorance of matters that this symbol indicates may cause serious injury or even death of user.
	Cautions	This symbol means that wrong handling or ignorance of matters that this symbol indicates may cause serious injury or property damage of user.
		This symbol means the matter that user should not do at any event.
		This symbol means that user should follow the instructions.

Symbols on Drawing

-  This symbol means that contents (high voltage, electric shock, warnings, etc.) to which user should pay attention are included.
-  This symbols means that a certain action is not permitted. Specific points not permitted are depicted around this symbol (for example, in the left drawing, disassembly is not permitted.).
-  This symbol means instructions or is used to force user to do a certain action. Specific instructions are depicted on the drawing (for example, the left drawing instructs user to detach power plug from an outlet).



Warnings



Warnings for disposal

- Do not throw used-up battery into fire places, which may cause fire and explosion.



Cautions



Cautions for installation

- The relevant law obliges users to have a qualified electrician carry out wiring work for power supply. Work by disqualified persons may cause fire and electric shock.
- Wiring work for communication cables needs techniques and experiences. For this type of wiring work, please consult to your local sales agent.
- According to the standard for electric work and other relevant regulations, install communication cables at the place away from power cables. The failure to install cables separately may cause fire, electric shock and communication troubles.
- Do not install the product on rolling table or sloping place.
Dropping or falling may cause damage on your product.
- In installation, avoid the place exposed to tremor or shocks, which may cause damages on your product.
- Even if your product is waterproof, do not install it slanted place of water leakage, which may cause a short circuit.
- For the product of wall-mounting type with fixing pegs, keep it safely.
Fixing pegs may cause injury of user.
- Install the product of wall-mounting type carefully not to drop from the wall. Dropping due to earthquake or tremors may cause injury of user.
- When installing the product on the wall, consider the thickness and material of the wall.
Dropping in use may cause injury of user.







Cautions for Use

- Do not put heavy thing on the product. Dropping or falling due to heavy things on it may cause injury of user.



Cautions for Repairs and Maintenance



- Clean the dust inside the product regularly. Failure to clean the dust for long time may cause fire. For inspection and cleaning of the inside of product, please contact your local sales agent.
-  • When putting your hands into the inside of equipment, be sure that plug is already detached form an outlet or circuit-breaker is turned off.
-  • Be careful not to expose the product to benzene, thinner or hot water.
-  • Do not expose detergent directly to the product in a way of spaying, etc.
-  • Moving equipment, be sure that the plug is detached from an outlet.
- For equipment whose cables are connected to terminals, please contact your local sales agent or qualified electrician.
- When replacing old fuse with new one, do not directly touch it with bare hands.
Use insulated tools or contact A/S center.



Warnings

Cautions for Use

- Do not install the product at bathroom or at the place near a washing machine, or at other humid places. It may cause fire or electric shock.
- Do not install the product at the place near a dresser, humidifier or heater. Also avoid the place exposed to spark, heat or humidity. All of them may cause fire and electric shock.
- Do not install the product at the place exposed to dust, metals and harmful gas such as hydrogen sulfide gas, all of which may cause fire and electric shock.



- Do not install the product at the place exposed to water and chemicals. This may cause fire and electric shock.
- Do not scratch, break or arbitrarily process power cable, which may cause fire and electric shock. Putting a heavy thing on a cable, heating it or pulling it may cause impairment on it.
- Do not place power cable at the place near heating equipment. It may cause damage of cable's clothing material, which result in fire and electric shock. When detaching plug from an outlet, do not pull power cable.
- Damages on power cable may cause fire and electric shock. When detaching plug from an outlet, please hold the plug tightly.
- Do not detach plug from an outlet with wet hand. It may cause electric shock.



- When using the existing wiring, be sure of the suitability of it to the product and install the product. Failure to this caution may cause fire.



- When moving equipment, be sure that plug is detached from an outlet and communication cable is disconnected. Damage on cables may cause fire.



- Voltage other than prescribed rated voltage is not permitted, which cause fire and electric shock.
- Do not use power terminal of product's main body in other equipment than prescribed ones. It may cause fire and short-circuit.



- In wiring work, use the designated wiring materials.
Wiring work using other materials than designated ones may cause fire.



- The equipment without waterproof marking shall not be installed at the place water leaks. It may cause electric shock and short circuit.
- When working, be sure that power is disconnected. Failure to disconnect power may cause electric shock.



- Be sure that the power cable is connected and earths according to designated method. Failure to connection and earth may cause fire.



- Do not connect power to other terminals than designated ones.
It may cause fire and electric shock.



- When building a system with the product, do not connect the product other equipment than designated one. It may cause fire.



- When installing A/C switch, do work after removing the substance that may cause short circuit or electric shock.
- Before installing or providing A/S service, be sure that the power is disconnected.



Warnings

Cautions for Use

- This product is only for home. Do not use the product for industrial or military use.
- Do not handle the equipment with wet hand, which may cause electric shock.
- Do not place wet or metallic materials on equipment. Water leakage or intrusion of metallic materials may cause fire and electric shock.
- Do not block the ventilating opening of equipment or put alien substances into it, which may cause fire and electric shock.
- Do not use battery that is not designated or mix new battery with old ones. Insert batteries to fit their polarity. Explosion or leakage of battery may cause fire and injury of user.
- When visitor's image or voice is not displayed on screen or not sounded from speaker, please check his/her identity before opening the door and contact our A/S center.
- Do not use equipment when lightning is expected or strokes. It may cause fire and electric shock.



- Do not open rear cover, cabinet and cover of equipment. It may cause electric shock.



- Do not modify power cable or pull it with excessive strength, which may cause fire and electric shock.
- Do not modify equipment. It may cause fire and electric shock.
- Call signal may cause damage on user's hearing ability.



Cautions for Abnormality

- When power cable is broken (exposure of core or short-circuit), do not fail to replace broken cable with new one. Failure to replace broken power cable may cause fire and electric shock.
- When detecting any abnormalities in equipment (communication is not available, images do not be displayed on screen, calling is not available, or abnormal sound is heard), immediately detach plug from an outlet, or turn off circuit breaker or detach batteries from equipment (in case that equipment has no plug) before requesting repairs to sales agent or A/S center. Keeping connection to power supply may cause fire and electric shock.
- When alien substances go into equipment, immediately detach plug from an outlet, or turn off circuit breaker or detach batteries from equipment (in case that equipment has no plug) before requesting repair to sales agent or A/S center.
- In the case of smoke or smell of unknown origin from equipment, keeping use it may cause fire and electric shock. Detach plug from an outlet, or turn off circuit breaker or detach batteries from equipment (in case that equipment has no plug) and be sure to check no more smoke or smell from equipment before requesting repair to sales agent or A/S center. Since personal repairing work by user may serious accidents. In any case, do not repair equipment with your own hand.
- When dropping equipment or breaking its cabinet, detach plug from an outlet, or turn off circuit breaker or detach batteries from equipment (in case that equipment has no plug) before requesting repair to sales agent or A/S center. Keeping use equipment may cause fire and electric shock.
- Avoid direct exposure to sunlight and store equipment at the place free from dust and high temperature as you can. High temperature of equipment may cause fire and electric shock.



Safety Instructions, Warnings, and Cautions of Each System

- This equipment is electronically precision equipment, so do not arbitrarily disassemble it.
- In installation of the product, do not fail to follow the specifications (specifications offered by KOCOM).
- Do not touch the product with alien materials (for example, sticker, magnet, opener, metal chopstick, etc.) or insert them into the product (it may cause reduction of the product's durability and harmful results to user as well).
- In the rainy season, water is likely to penetrate into the product along the wiring. Thus, U-type finishing is recommended as a desirable method of end part finishing.

Video Phone

- In assembling the product, be careful that wall-mounting pegs should not contact with wirings.
- In connection of cables, strip its insulation off as much as necessary (Excessive stripping off its insulation may cause short circuit).
- Be careful that signal cables should not be wired with A/C wiring (it may cause poor display quality).
- Do not drop handset (its damage or short-circuit due to drop may make communication impossible).
- When connecting wires to terminals, use standard screwdriver (otherwise, screws may loosen, which will result in disconnection of wiring).
- Do not clean CRT screen with wet towel or cloth. When water penetrates into the product, it may cause short-circuit.
Do not fail to clean it with dry towel or soft cloth.
- Do not install camera at the place where water penetrates or leaks. Penetration or leakage of water may cause electric shock or short circuit.

4-Line Related Products

- In wiring work, be careful that wirings should keep away from the wall-mounting pegs or other furniture at regular interval. Contact of wiring with wall-mounting pegs, etc. may cause short-circuit, electric shock and fire (it is applied to all products with wall-mounting pegs).
- Use the prescribed standard wirings. Non-standardized wirings may give adverse effects on operation of product (it is applied to both video phone and CCTV).

Product Features

■ Main Body

1. Bus type wiring that is adopted for connection between monitor and guardroom makes product installation easier.
2. Since the product is adjusted to AC 220V or AC 110V, no additional DC adapter is needed.

■ Instructions for Right Use

- Do not place the product near humidifier or heater. High temperature and humidity may cause unexpected mechanical troubles of the product.
- Do neither drop main body and front door camera nor great impact on them.
- Do not close main body to the equipment emitting strong magnetic force (TV, speaker, etc.)
(It may cause trembling or distortion of screen image which result in breakdown.)
- In cleaning, do neither contact the product with wet hands nor use volatile substances such as benzene or thinner.
- To maintain high-definition of screen image, wash main body and window part of camera from time to time.
- As this equipment is an electronic precision instrument and high-voltage occurs in its interior, do not disassemble the equipment arbitrarily.

 All the above-mentioned cases constitute the causes of product's breakdown. Pay attention to these instructions when handling the product.

■ Instructions for Installation

- Appropriate circuit breaker should be installed in interior wiring part of building.
- When disconnecting power cable form connector, fix the cable not to contact with second-order side or case.
- The color of GND wire should be green or yellow and be fixed to chassis (GND-marked position) using washer with proper elasticity together.

Components

■ Main Body Components

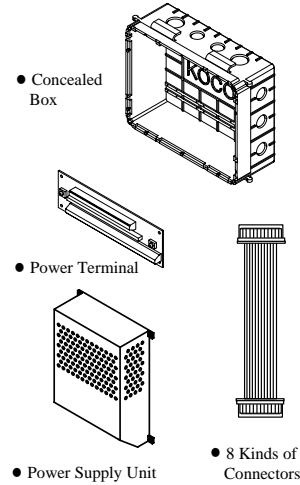

■ Front Door Camera Components

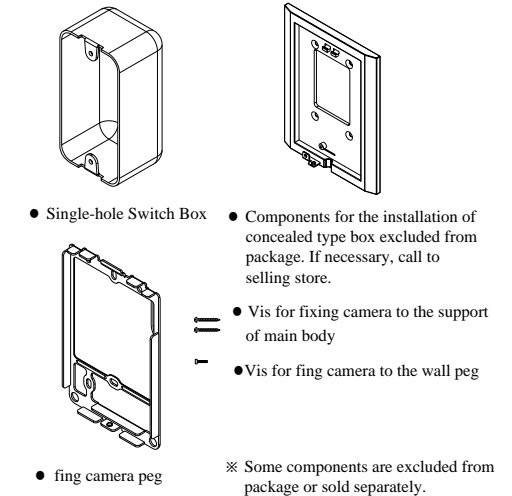

Product Configurations

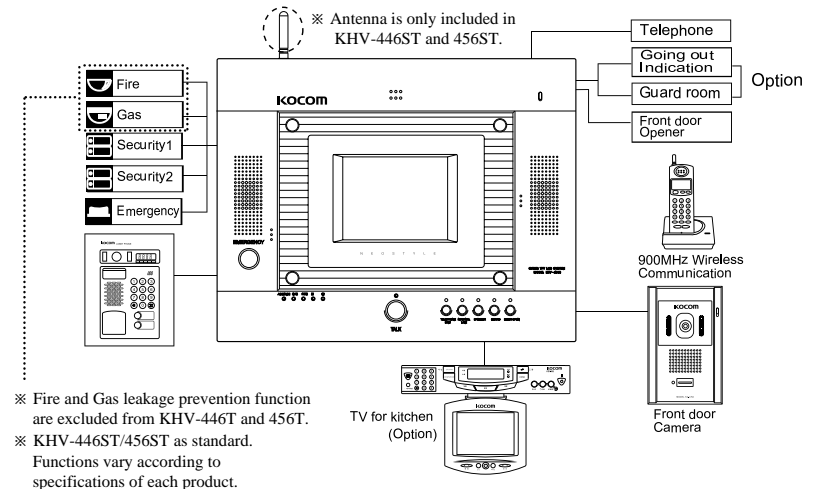

Name of Each Part

■ Main Body

KHV-446ST and 456ST as standard
Functions vary according to the specifications of each product.

※ Extensions can be used only where direct dialing system is installed.

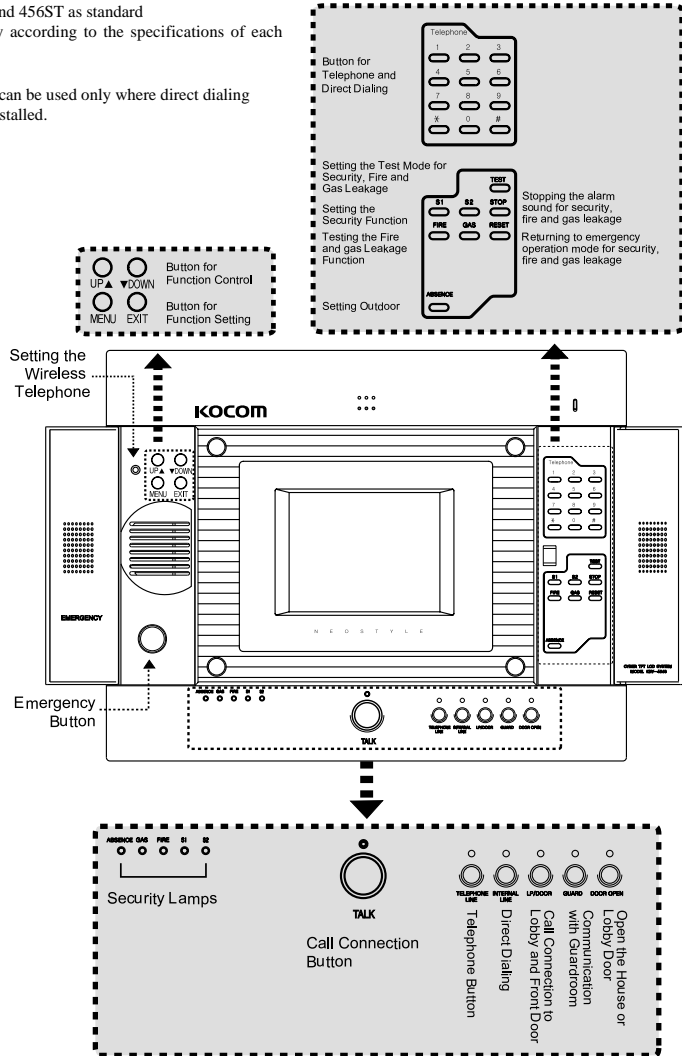

■ Camera (KC-C50)

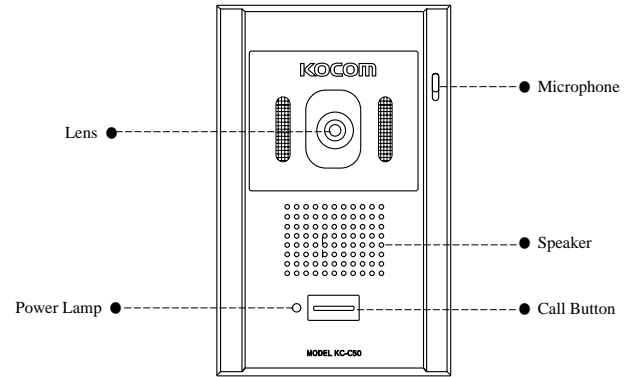

■ Front Door Camera (KC-C50) Wiring Diagram

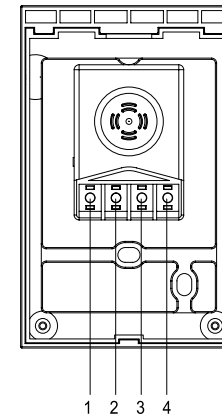

- 1. Blue: +12V (Camera Power)
- 2. Yellow: GND
- 3. Red: VOICE (Camera Voice Signal)
- 4. White: VIDEO (Camera Video Signal)

Overall Wiring Diagram

● Specifications for the connection at the rear side of main body

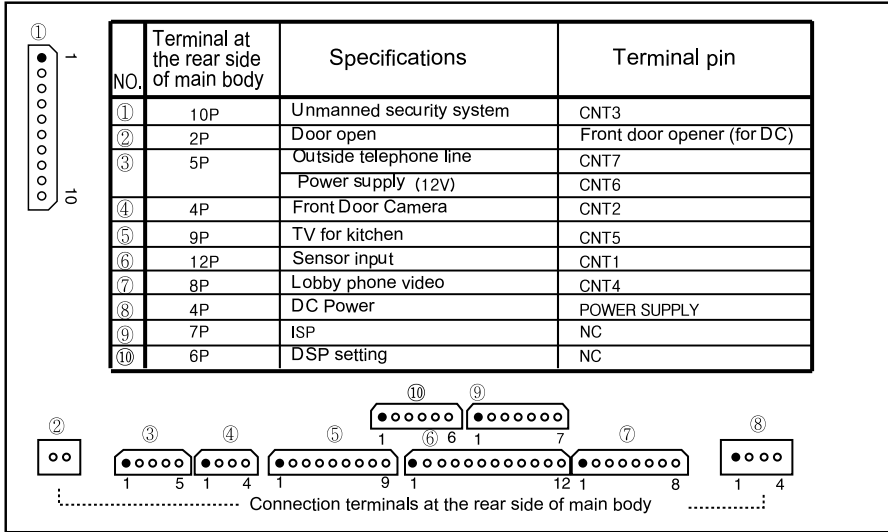

■ Specifications for Pins of Main Body

NO		1	2	3	4	5	6	7	8	9	10	11	12
1	Unmanned security system(J19)	Da	Db	G1	G2	G3	G4	G5	L1	L2	AGND		
3	(outside telephone line) Power 12V(J7)	TIP1 (outside telephone line)	RING2 (outside telephone line)	N.C	N.C	Power 12V							
4	Front door Camera (J4)	12V	GND	VOICE	VIDEO								
5	TV for kitchen (J11)	D1	D2	A1_1	A1_2	A2_1	A2_2	V-IN	GND	NC			
6	Sensor input (J20)	FIRE	AGND	12V	GND	GAS_SIG	12V	GUA_SIG	12V	GUA_SIG	EMG_IN	EMG_OUT	GND
7	Lobby phone video (J21)	AGND	LV2_OUT	AGND	LV1_OUT	AGND	LV2_IN	AGND	LV1_IN				
8	DC Power (J23)	AGND	24V	GND	12V								

■ Terminal Wiring Diagram

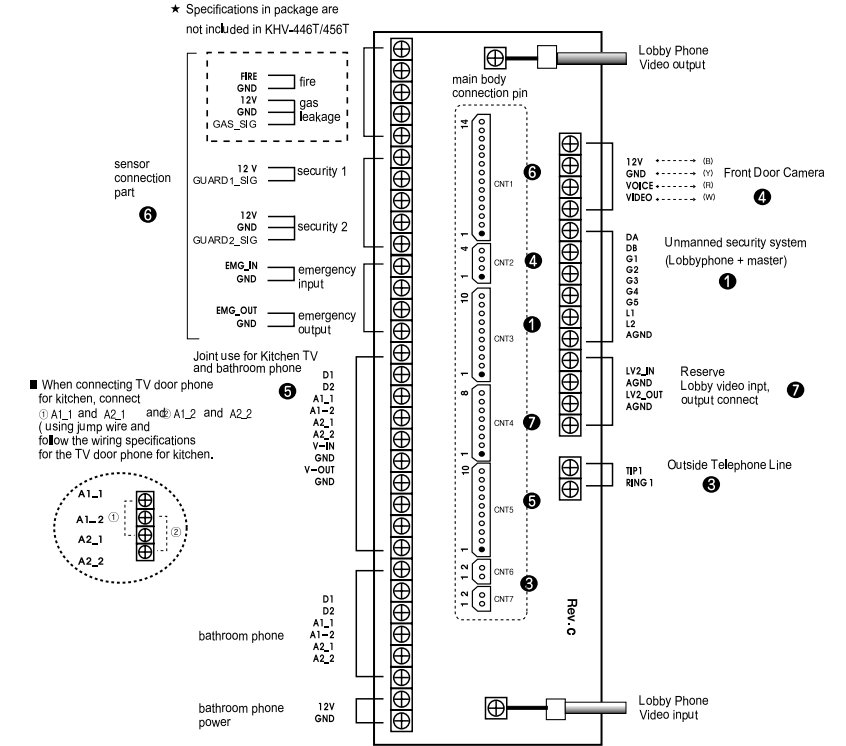

■ Specifications for Pins of Terminal

NO		1	2	3	4	5	6	7	8	9	10	11	12	13	14
1	Unmanned security system (CNT3)	AGND	L2	L1	G5	G4	G3	G2	G1	D B	D A				
3	Power 12V (CNT6)		12V												
3	outside telephone line (CNT7)	RING1	TIP1												
4	Front door Camera (CNT2)	VIDEO	VOICE	GND	12V										
5	TV for kitchen (CNT5)	Spare GND	Spare V_OUT	GND	V_IN	A2_2	A2_1	A1_2	A1_1	D2	D1				
6	Sensor input (CNT1)	GND	ENG_OUT	GND	ENG_IN	SIGNAL	GND	12V	SIGNAL	12V	SIGNAL	GND	12V	AGND	FIRE
7	Lobby phone video (CNT4)	AGND	LV2_OUT	AGND	LV1_OUT	AGND	LV2_IN	AGND	LV1_IN						

Installation of Main Body

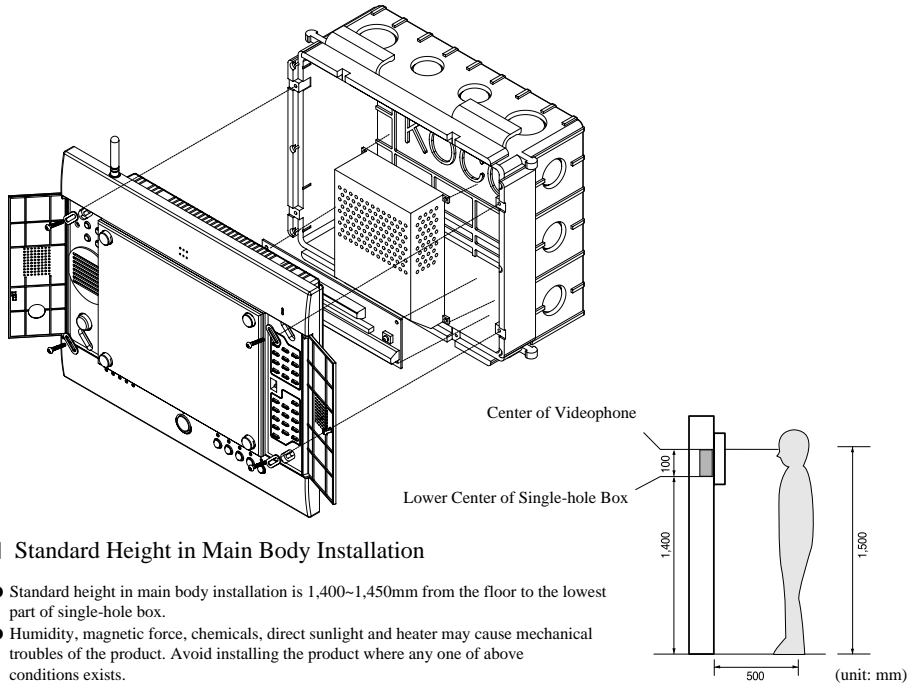

Standard Height in Main Body Installation



- Standard height in main body installation is 1,400~1,450mm from the floor to the lowest part of single-hole box.
- Humidity, magnetic force, chemicals, direct sunlight and heater may cause mechanical troubles of the product. Avoid installing the product where any one of above conditions exists.

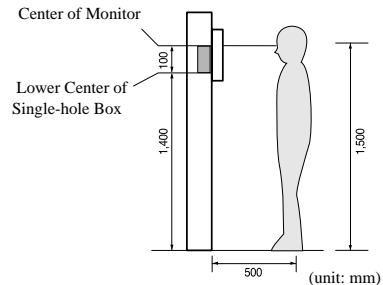

Camera Installation

■ Basic Installation Method of Front Door Camera (KC-C50)

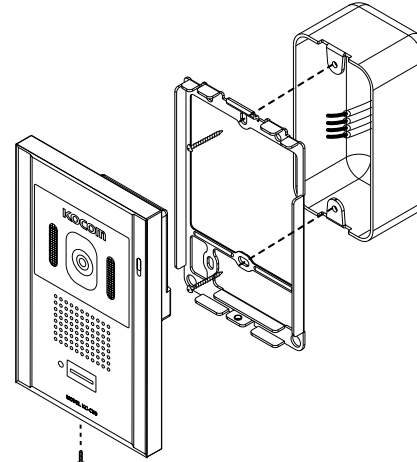

■ Lens Control Method toward up/down and left/right

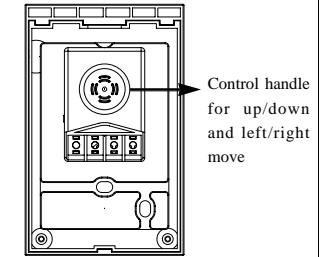

Standard Height in Camera Installation



- Standard height of front door camera is 1,400~1,450mm from the floor to the lowest part of single-hole box (for concealed type, 1,400~1,450mm from the floor to the camera box).
- In the event that height of front door camera is out of range from 1,250mm at the lowest to 1,550mm at the highest, adjustment of lens angle alone cannot control video image you want. Thus, be careful to install camera according to the proper range of height.

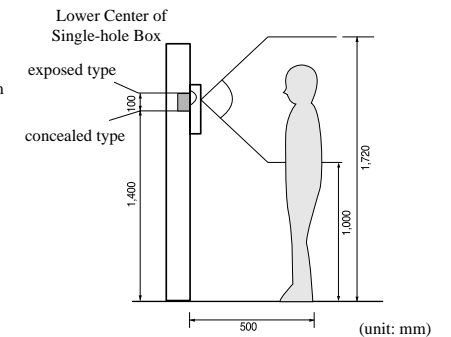

Warnings in Installation

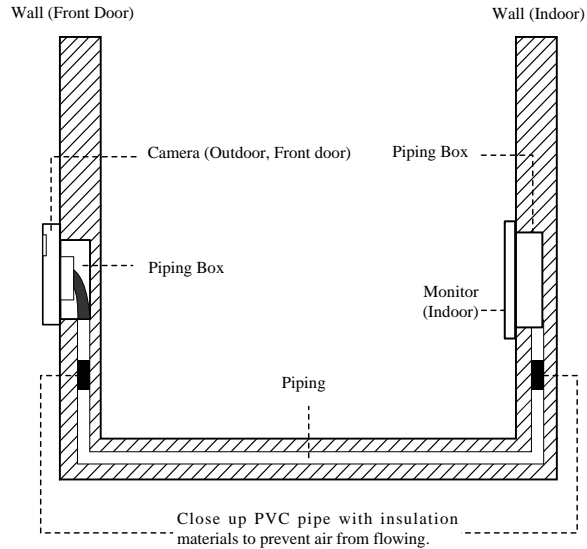

Closing up pipe as shown in the figure removes the temperature difference between indoor and outdoor as well as prevents the humidity and frost on the window of front door camera.



- When installing monitor and front door camera, avoid where direct light or back light come into.
- Install the front door camera where rainwater cannot reach. Standard height of monitor is 1,450~1,500mm from the floor to the center of CRT.
- Install the front door camera after cement of installed wall becomes fully dry and solid.
- When installing the product in the wintertime whose temperature is below 5℃, connect the equipment after 2 hours from installation. Temperature gap between indoor and outdoor makes dews inside of the monitor and camera, which may cause mechanical troubles of equipment.
- When installing the monitor and front door camera, avoid where equipment can be exposed to direct heat or harmful gas.

Self-alarming Test

■ Purpose of Test

This function offers self-testing by operating system in order to minimize damages due to system breakdown in emergencies(sensor test is unavailable). Sensor test should be carried out after sensor operates. Before sensor operation test, please contact administration office or KOCOM A/S headquarter).

■ Test Methods (general functions)

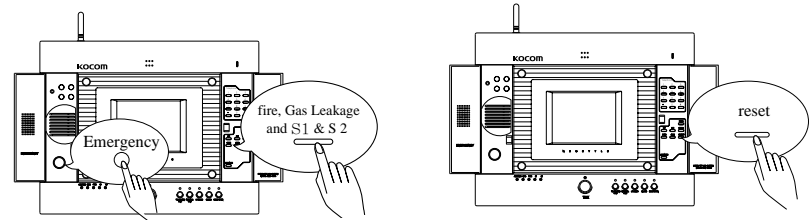

- After pressing the "Test" button,
- Pressing the emergency (fire, gas leakage and s 1) button, concerned alarming sound rings and concerned lamp flickers (For fire and gas leakage, concerned lamps are turned on).

- Pressing the "Reset" button, alarming lamp is turned off and alarming sound stops.
- Pressing the "Stop" button, alarming lamp and alarming stop LED flicker, while alarming sound does not ring (For fire and gas leakage, lamp and LED are turned on).

※ Fire and gas leakage function is unavailable in KHV-446T and 456T.

Adjusting the Video Display and Call Sign Volume (This function is available only when LCD screen is turned off).

■ Adjusting the Video Display (Color)

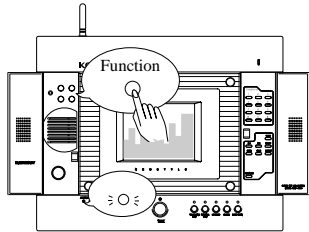

- Press the Function key once.
Among LEDs at the left-bottom side of LCD, 1st LED is turned on.
- Using up/down key, adjust the color of LCD (8 grades).
After adjusting the color, pressing end key or waiting for 5 seconds, 1st LED among the LEDs at the left-bottom side of LCD is turned off and mode for adjusting the screen display is ended.

■ Adjusting the Video Display (Brightness)

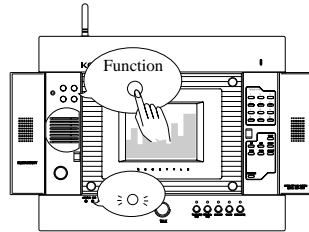

- Press the Function key twice.
Among LEDs at the left-bottom side of LCD, 2nd LED is turned on.
- Using up/down key, adjust the brightness of LCD (8 grades).
After adjusting the brightness, pressing end key or waiting for 5 seconds, 2nd LED among the LEDs at the left-bottom side of LCD is turned off and mode for adjusting the screen display is ended.

■ Adjusting the Call Sign Volume

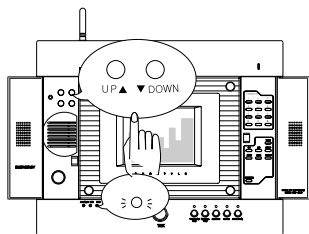

- Press the Function key three times.
Among LEDs at the left-bottom side of LCD, the 3rd LED is turned on.
- Then, using up/down key, adjust the call sign volume.
After adjusting the call sign volume, pressing end key or waiting for 5 seconds, 3rd LED among the LEDs at the left-bottom side of LCD is turned off and mode for adjusting the call sign volume is ended.

Communication with Front Door (General Function)

■ Communication with front door when a visitor comes

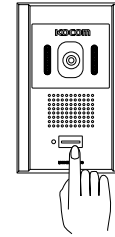

- If a visitor presses the call button of front door camera, call sign rings from the indoor monitor and its video screen is automatically turned on, displaying the visitor.
(Lobby/Front Door LED flickers)

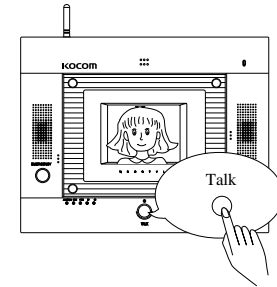

- Pressing "Talk" button or "Lobby/Front Door" button, talk becomes available.
- After Talk, pressing the "Talk" or "Lobby/Front Door" button, video screen is faded out. However, the talk over 5 minutes automatically blocks the call.
To make talk again, press the "Lobby/Front Door" button.

■ If you want to identify visitor without talk

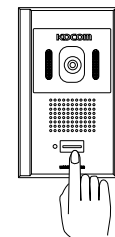

- If a visitor presses the call button of front door camera, call sign rings from the indoor monitor and its video screen is automatically turned on, displaying the visitor.
- If you want to identify the visitor without talk, please see the video screen without pressing the "talk" button.
(After 30 seconds, video screen is automatically turned off).

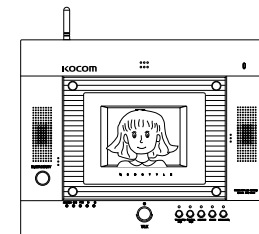

Automatic Opening the Front Door (Optional)

- This function becomes available only when opener is installed at common or house front door and connected to main body. (Only DC opener can be used.)

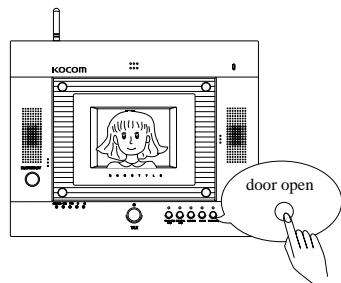

- Pressing the "door open" button during the talk with common or house front door, common or house front door is opened, respectively.

Call using Direct Dialing System (Call between houses)

- ※ This function becomes available only when direct dialing system is installed.

- In direct call to other household

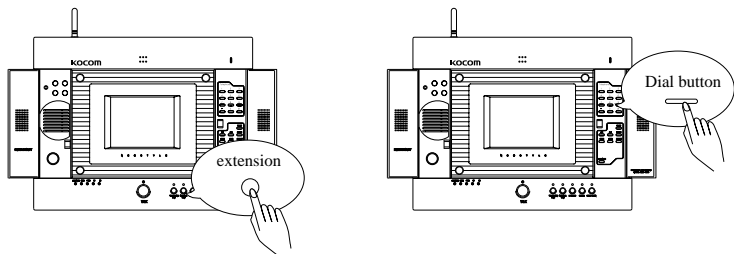

- In direct call to other household, internal line LED continues to flicker until the other side receives call. If the other side does not receive the call, internal line LED is turned off after 30 seconds.
 - Press the "internal line" button on main body.
 - Within 5 seconds, press the numbers of building and house to be called. After 5 seconds from pressing the "internal line" button, call connection is ended. If calling again, after pressing the "internal line" button, press the number of building and house to be called.
- Ex) Call to House No. 302 in Building 102
 0+1+0+2[4 digits of building No.]+0+3+0+2[4 digits of house No.] Pressing 4 digits of building No. and 4 digits of house No. in order, call to the concerned house becomes available.
- (Call to administration office: when system is installed in integrated administrative office): Pressing the guard button for more than 3 seconds, integrated administration office is called.
- Call from other house, internal line LED flickers.

- Incoming Call from Other House using Direct Dialing
 (Maximum call time of incoming call from other house is set at 5 minutes.)

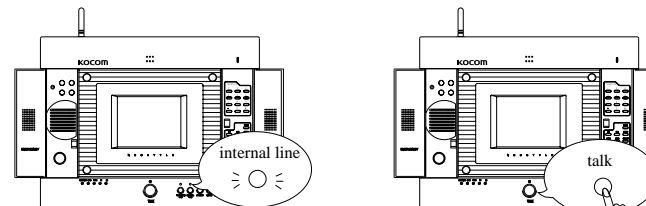

- In incoming call from other house, extension LED on main body flickers and bell tolls.
- Then, if you want to make telephone talk, press the "talk" or "internal line" button for call connection.
- After the talk is finished, pressing the "talk" or "internal line" button, the talk is ended. In addition, when one of sender or receiver disconnect the line, the talk is automatically ended.

Communication with Guard (General Function)

- Call from House to Guard * This function becomes available only when guard equipment is installed.

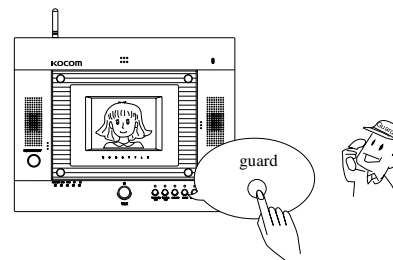

- After you press the guard button and guard respond to your call, communication with guard becomes available.
- When communication between house and guard exceeds 5 minutes, communication is automatically ended.

- Bell of front door or outside telephone line rings during the communication between house and guard

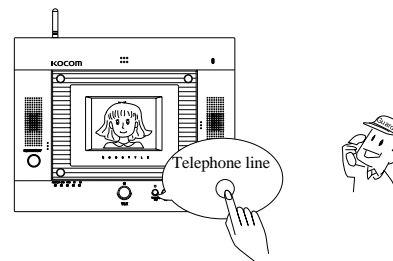

- When front door or telephone bell rings during the communication between house and guard, press the function button of flickering LED for communication.

- Call from Guard to House

Call sign rings at the main body for house. Then, pressing the "talk" or "guard" button, communication with guard becomes available.

Operation in Call during the Communication

- Call from outside telephone line during the communication with guard or front door

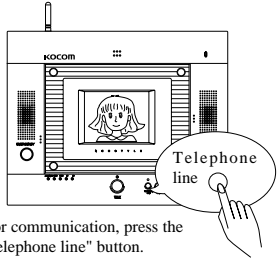

- For communication, press the "Telephone line" button.

- Call from front door camera during the outside telephone call

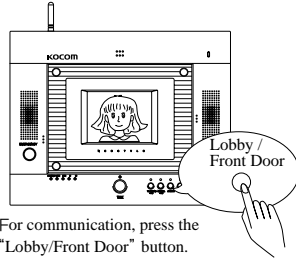

- For communication, press the "Lobby/Front Door" button.

Priority Call

- Simultaneous calls from outside telephone line, guard and front door

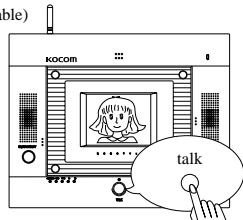
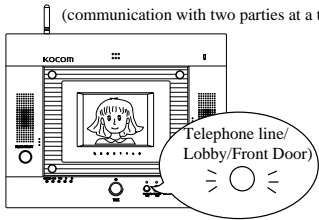

- In case of simultaneous calls from outside telephone line, guard and front door (called LED flickers), the first pressed button among Telephone line, guard and front door is first linked.

- For telephone call connection, press the "talk" button (Telephone line LED is turned on).
- In the case of simultaneous calls from Telephone line, guard and front door, outside telephone call among them is automatically connected with first priority.
- After outside telephone call is ended, pressing the "talk" button, guard and front door are connected in order (Telephone line LED is turned off).

- Simultaneous calls from guard and front door

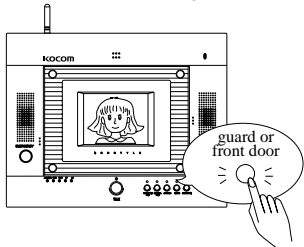

- In case of simultaneous calls from guard and front door (LEDs of guard and front door flicker), the first pressed button between the two is first linked.

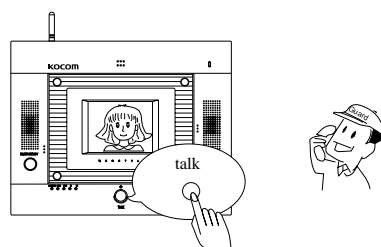

- Pressing the "talk" button, communication with guard becomes available (Guard LED is turned on).

Detoured Communication with Common Gate

- In absence, a visitor calls to house at the common gate camera...

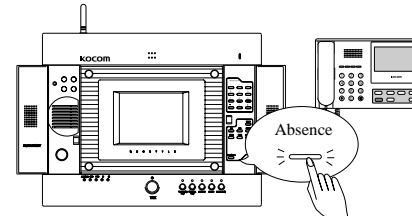

- If a visitor calls to house at the camera of common gate and the equipment is set at "Absence" mode while user is absent, call signs are also heard at guard.

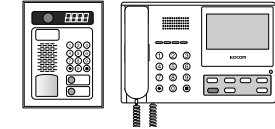

- When call connection is made between guard and a visitor at common gate, guard notice to a visitor that user is now absent.

- If guard button is pressed at a house when detoured communication is being made between guard and a visitor?

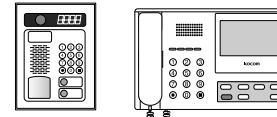

- When call connection is made between guard and a visitor at common gate, guard notice to a visitor that user is now absent.

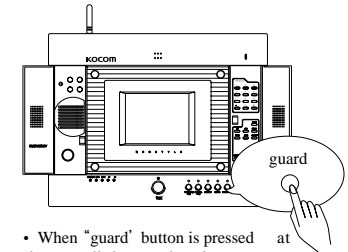

- When "guard" button is pressed at a house, call signs are heard at guard.

Telephone Call

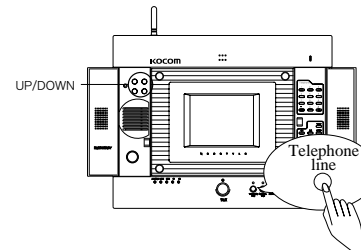

- When telephone rings, pressing the "Telephone line" or "talk" button, communication becomes available.
- For outgoing call, press the "Telephone line" button and telephone number in order.
- Sensitivity of outside telephone line may vary according to the user's environment. During the telephone call, properly adjust the call sensitivity using up/down key.

■ Operation in Fire

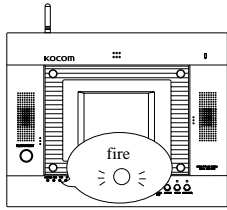

- When a fire takes place, fire-alarming sound is heard (Fire LED is turned on).

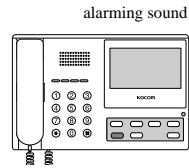

- The number of house where a fire takes place is displayed at guard and call signs is heard.



■ Operation in Gas Leakage

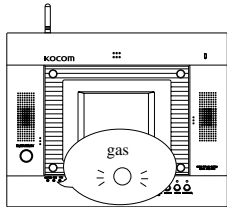

- In gas leakage, gas leakage alarming sound is heard (Gas leakage LED is turned on)

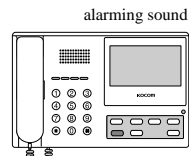

- The number of house where alarming sound occurs is displayed at guard and call signs is heard.



■ Operation in Emergencies

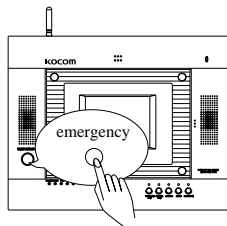

- When an emergency occurs at house, press the "emergency" button (Emergency LED flickers)

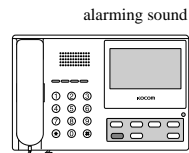

- The number of house where alarming sound occurs is displayed at guard and call signs is heard.



■ Setting the Security Mode 1 and Operation in Unlawful Entry by Thief

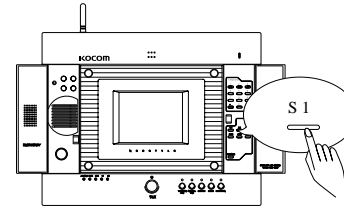

- Pressing the "s 1" button, security mode 1 works (S 1 LED is turned on).

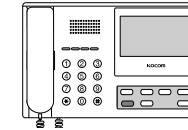

- When security sensor 1 detects an invasion, s 1 LED flickers and alarming sound is heard at guard for notice of unlawful entry by thief.



■ Setting the Security Mode 2 and Operation in Unlawful Entry by Thief

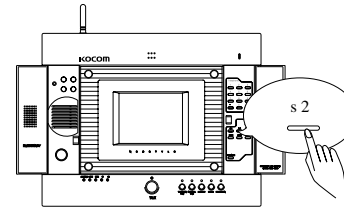

- Pressing the "s 2" button, security mode 2 works (S 2 LED is turned on).

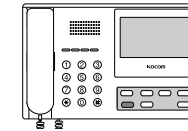

- When security sensor 2 detects an invasion, s 2 LED flickers and alarming sound is heard at guard for notice of unlawful entry by thief.



■ Setting the Security Mode and Operation in Unlawful Entry by Thief

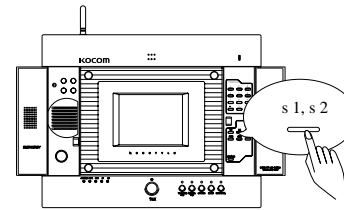

- Just when "s 1" or "s 2" button is pressed, if sensors are not connected or door is being open, the equipment only sends the concerned alarming sounds without setting security mode.

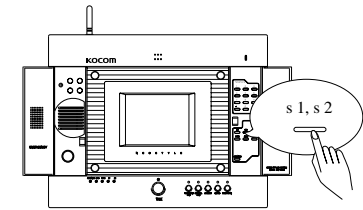

- If security mode cannot be set, user should close the door where sensor is attached in order to set security mode.
- For infrared detector, remove the moving objects from surroundings of detector before setting security mode.

■ Release of Security Mode

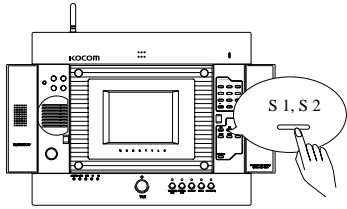

- Press the security button now being set to turn off security LED (release of security mode). (To release the security mode, the door with sensor should be being closed.)

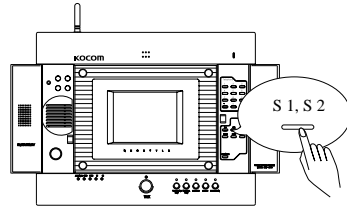

- When security alarming sound is heard, close the door and press the "security 1" or "security 2" button, and concerned LED will be turned off and security mode is released.

■ Setting the Security Mode While Being Out

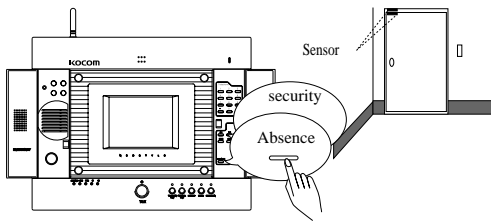

- Just before going out, press the "Absence" button, and Absence LED will be turned on.
- After pressing the "Absence" and "security" button in order, user should go out from the house through the door with security sensor within 60 seconds. At this time, the door with security sensor should be closed.
- If the door with security sensor is opened after 60 seconds from user's pressing the "Absence" and "security" button in order, security alarming sound is heard after 30 seconds from the time when the door opens.
- Absence LED flickers for 60 seconds after user presses the "Absence" and "security" button. User should go out through the Gate within 60 seconds (considering the time required in user's pressing the "outdoor" and "security" button and going out, standby time is set at 60 seconds).

■ Releasing the Security Mode When returning Home

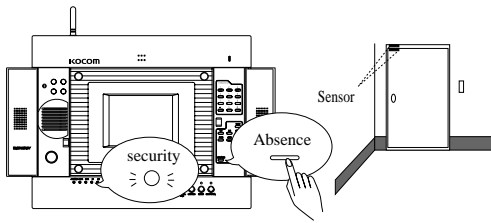

- When returning to home and opening the door (security LED is turned on), user should press the stop/reset button within 30 seconds to release the security and Absence mode. At this time, the door with security sensor should be closed.
- If user fails to release the Absence and security mode within 30 seconds, alarming sound is sent to guard for emergency call (the equipment recognizes that security sensor is working).

■ Setting the Absence Mode and Operation in Emergencies

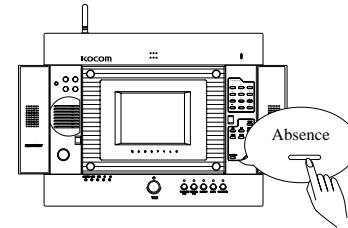

- Setting the Absence Mode and Operation in Emergencies
- When user goes out from the house, press the "Absence" button (Absence LED is turned on).
- When emergency occurs, alarming sound is sent to guard.

emergency alarming sound

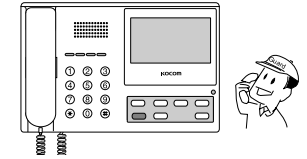

- At guard, house number that sends emergency alarming sound appears at displaying LCD window with emergency sign.

■ Stopping the Alarming Sound

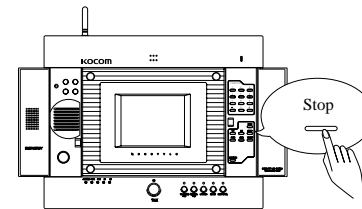

- While alarming sound is heard, press the "stop" button to turn off the alarming sound.
- Pressing the "reset" button, alarming sound is turned off and not sent to guard.

Alarming sound

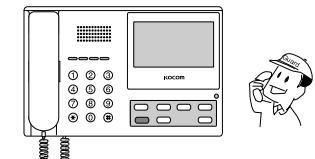

■ In the event that an emergency occurs when alarming sound is stopped...

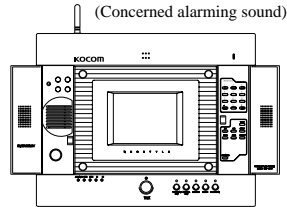
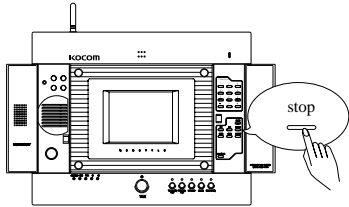

- While alarming sound is heard, the concerned LED flickers.
- Pressing the "stop alarm" button, alarming sound is turned off.

- In the event that other emergency occurs while alarming sound is stopped, "stop alarm" mode is released and both the previous and new alarming sounds occur in order.

■ Returning to Alarming Mode

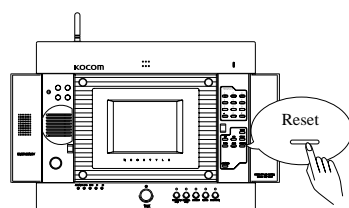
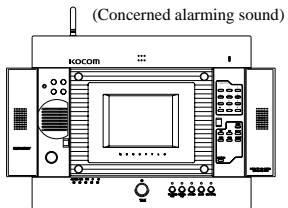

- When alarming sound is being heard or stopped

- Pressing the "reset" button, alarming sound is turned off, with alarming state returning to normal state and alarming LED being turned off (Reset).
- Only if a situation that caused alarming state is removed, reset to alarm mode works.

Interlocked Communication with 900MHz Wireless Telephone (KHV-446ST/KHV-456ST Products)

■ Interlocked Communication Method

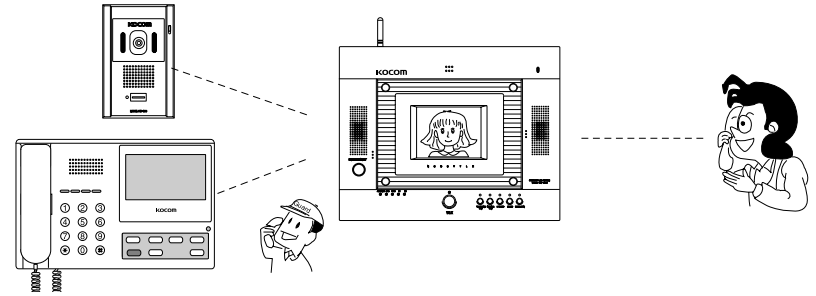

- In case of calls from Gate camera or guard, or incoming telephone call, user can communicate with other party using main body as well as 900MHz wireless telephone.
- For outgoing general telephone call, call with Gate and guard, and direct dialing call, user can use wireless telephone for communication.

■ A Call from Gate (or Guard) While Communication Using Wireless Telephone

- After hanging up the wireless telephone, press the "talk" button to communicate with Gate (guard or common gate).

■ Setting the Wireless Telephone

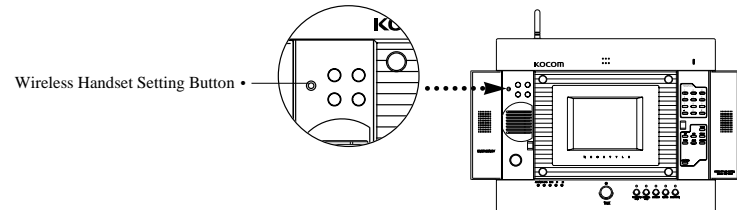

- Press the Wireless Setting button on the main body of Home Auto. Then, press the "function," "redial," and "1" buttons on wireless handset in order. After 2 ~ 3 seconds, user can hear beep sound from the handset, which indicating that setting is completed.

Direct Dialing Using Wireless Telephone (Model No.: KHV-446ST, KHV-456ST)

※ This function is available only if direct dialing system is installed.

■ Call to Other House

- Press the "outside" button on wireless handset, and user will hear the beep sound.
- Within 5 seconds, press the numbers of building and house to be called.
If no action is taken within 5 seconds after pressing the outside button, beep sound disappears and call is disconnected.
To call gain, press the outside button to quit the previous process and press the same button again.

ex1) Call to House No. 1302 in Building 102
"Outside" button +0+1+0+2{4 digits of building No.} +1+3+0+2{4 digits of House No.}

ex2) Call to House No. 302 in Building 103
"Outside" button +0+1+0+3{4 digits of building No.} +0+3+0+2{4 digits of House No.}

ex3) Call to other house within the same building (Same as the call to house in other buildings)
Call to House No. 402 in Building 104

"Outside" Button +0+1+0+4{4 digits of building No.} +0+4+0+2{4 digits of house No.}
To call other house, press the buttons in order.
Or user can call other house only by pressing its house No. (0+4+0+2 in example) and "#" button without pressing its building No.

=> Call to Guard (Guard master is installed in administration office): Press the "outside" and "#" button subsequently to call to guard.

When a call is successfully connected, call signals are heard, melodic sound is heard at the called house, and call signals are heard at wireless telephone. Press the "talk" or "internal line" button on main body installed at house or the "outside" button on wireless telephone to connect call.

■ Call through Direct Dialing (Call from Other House)

- When a call is connected from other house, internal line LED on main body and outside LED on wireless handset flicker. At this time, melodic sound and beep sound is heard from main body and wireless handset, respectively.
- If you want to communicate with sender using main body, press the "talk" or "internal line" button on main body. If you want to communicate with sender using wireless handset, press the "outside" button on the handset.

When user communicates with guard, makes exchanged communication (communication between house via guard) or communicates through direct dialing using main body, user cannot perform same functions using wireless handset, and vice versa.

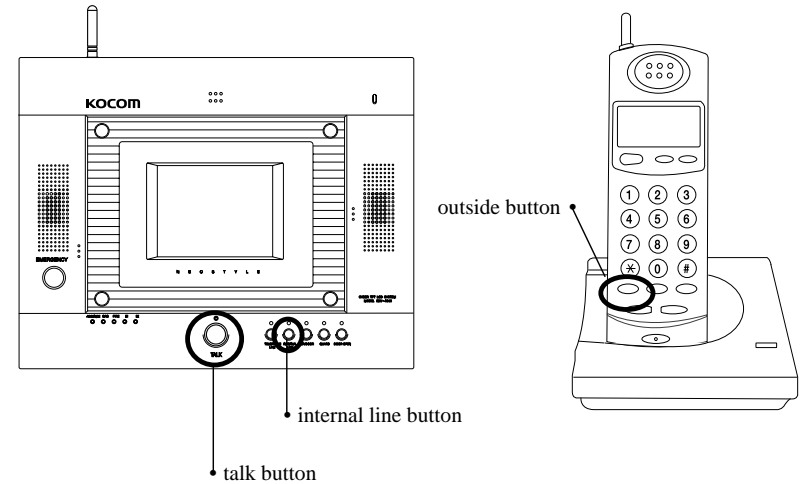

Read before requesting the repairing works...

Do not fail to check the following items before requesting the repairing works. If no troubles are found out after check, contact KOCOM's local service center.

Alarming Situation	Check Points	Actions
<ul style="list-style-type: none"> Power connection failure 	<ul style="list-style-type: none"> Please check whether power switch on the front-bottom side of main body is turned on. 	<ul style="list-style-type: none"> Turn on the power switch.
<ul style="list-style-type: none"> Failures in communication with Telephone line, common Gate, and guard 	<ul style="list-style-type: none"> Is outside telephone line connected to product installation place? Is common Gate or guard installed? 	<ul style="list-style-type: none"> Try to other handset. If no troubles are found, request A/S. Contact guard to inquire whether communication with common Gate or guard is available. Turn off and on the switch at the front-bottom side of main body.
<ul style="list-style-type: none"> Failures in security setting Failure in releasing the security mode 	<ul style="list-style-type: none"> Isn't the door open? (security sensor works) Isn't the wiring for security sensor disconnected? 	<ul style="list-style-type: none"> Close the door. Restore the damaged wiring.
<ul style="list-style-type: none"> Failures in returning to alarm mode 	<ul style="list-style-type: none"> Did you check the pertinent security sensor? Isn't the wiring for pertinent security sensor disconnected or short-circuited? Isn't the door where sensor is attached opened? 	<ul style="list-style-type: none"> For normal operation of returning to alarm mode, alarming factors should be checked and removed. Restore the disconnected or short-circuited wiring Close the door.
<ul style="list-style-type: none"> No call signal heard from Gate or guard calls 		<ul style="list-style-type: none"> Turn off and on the switch at the front-bottom side of main body.

KOCOM Home Auto User's Manual

(for Unmanned Security)

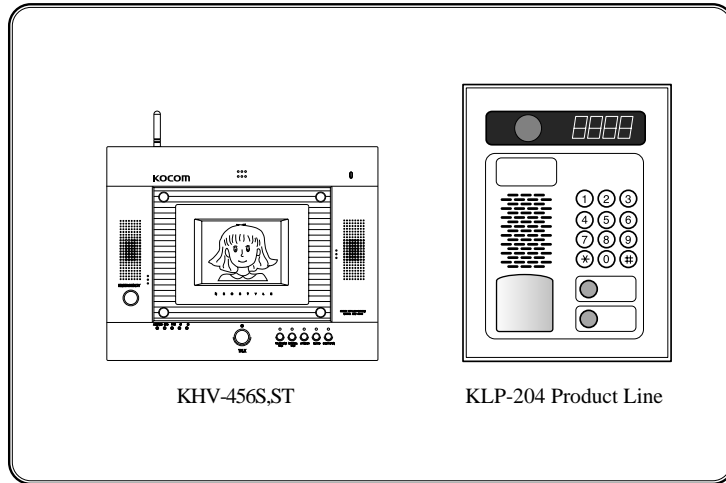

KHV-456S,ST

KLP-204 Product Line

How to Operate

- Call from Lobby Phone to House (ex) A call to house No. 1001

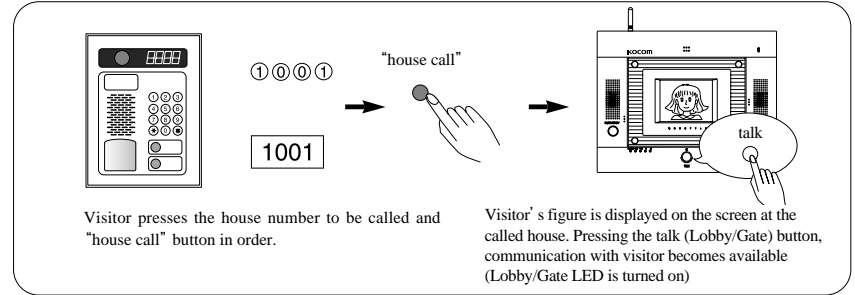

- Call from Guard while Communication with Lobby Phone

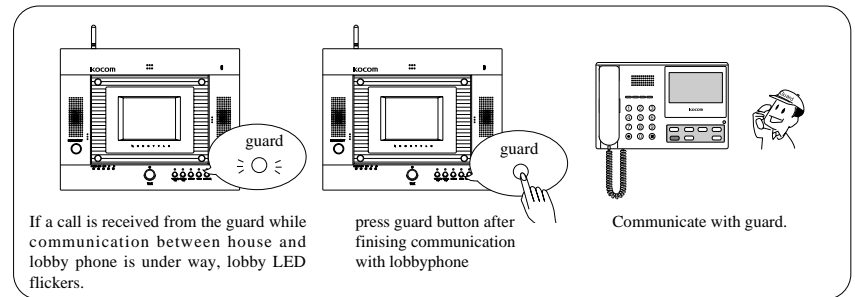

- A Call Sign from Telephone while Communication with Lobby Phone

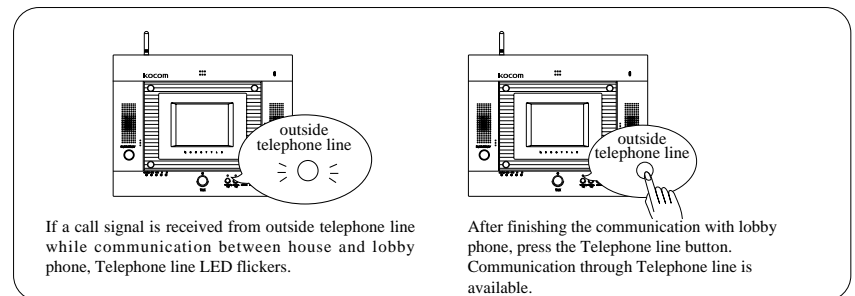

■ .Call from Lobby Phone while Communication with Guard

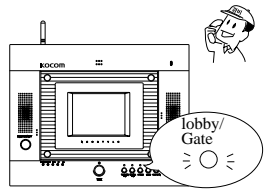
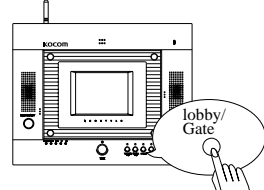
If a call is received from lobby phone to main body while communication between house and guard, lobby LED flickers.

After finishing the communication with guard, press the lobby/Gate button. With a visitor's figure displayed on screen, communication with lobby phone becomes available.

■ .Call from Lobby Phone during the Telephone Call

If a call signal is received from lobby phone while telephone call is under way, lobby/Gate LED flickers. After finishing the telephone call, press the lobby/Gate button.

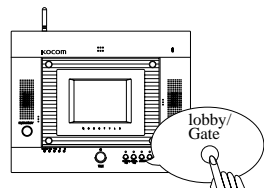
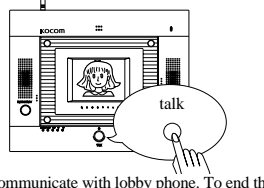
Communicate with lobby phone. To end the communication completely, pressing the talk or pertinent function button is required after finishing the communication. Otherwise ending the communication completely, communication state remains.

■ Closing/Opening the Common Gate

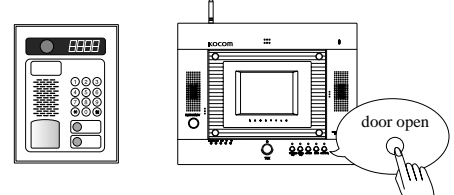

If pressing the door open button while communicating with lobby phone, common gate automatically opens.

How to Operate

■ Call from Lobby Phone to House

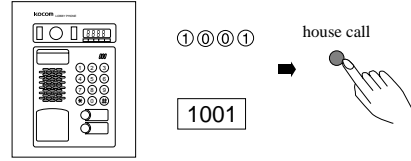
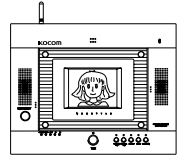
A visitor presses the house number to be called and "house call" button.

Lobby phone LED (house LED, call LED) that indicates its operation status is turned on and tone sound is heard.

If user presses the talk button at home, communication with lobby phone becomes available.

* In case that communication between lobby phone and house is under way, pressing the "door open" button at home, Common gate opens automatically.

■ Call from Lobby Phone to Guard

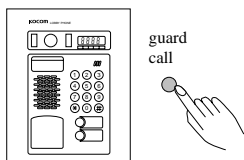
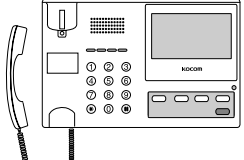



A visitor calls to guard by pressing the guard button on lobby phone (Lobby phone LED (guard LED, call LED) that indicates its operation status is turned on and tone sound is heard).

When, at guard, a guard hangs on the handset and presses the "5" button, communication becomes available (operation method may vary according to the specifications of product).

* In case that communication between lobby phone and guard is under way, pressing the "open" button at guard, Common gate opens automatically.

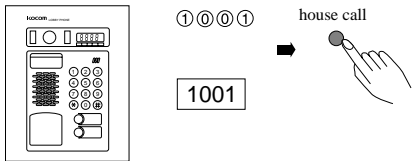
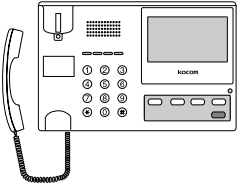
■ Absence

A visitor presses the house number to be called and house call (Lobby phone LED [house LED, Call LED] is turned on.

In absence, house and absence LED flicker first, and guard and call LED is turned on next. Call is sent to guard and communication with guard becomes available.

■ How to Open Common Gate using Card

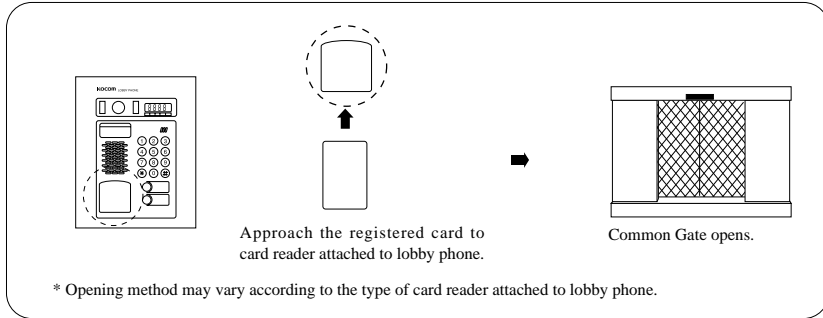

■ How to Open Common Gate using Password

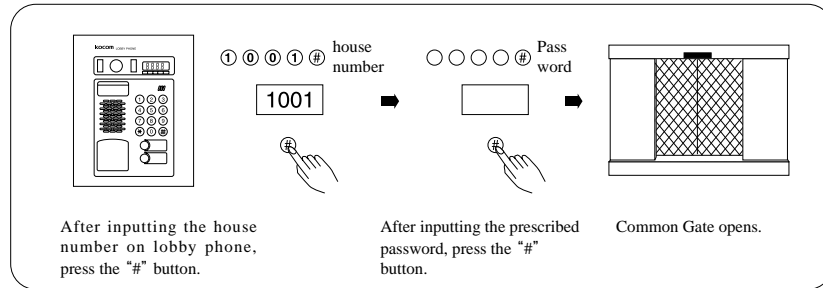

■ House Password Change at Common Gate

