

## ⚠ Caution

- 1 Please pay attention that the password can be changed by someone who call at the common gate.  
In this case, please cut off the phone when the beep tone sounds at handset.
- 2 Take care not to expose the password.
- 3 All functions of the KLP-1000 can be stopped by pushing “#” button.
- 4 If the melody of KDP-205 sounds and communicate continually to KLP-1000 at the common gate, please let the handset of KDP-205 be lightly on position
- 5 Do not push the hook switch in holding a handset to your ear.

## Warranty



To receive after service, have the following ready when you contact our branches

1. Name of the product
2. Model number of the product
3. The area of problem
4. Phone number and address at which you can be contacted.

## Warranty Card

PRODUCT	
MODEL	
DATE PURCHASED	
WARRANTY PERIOD	
AGENCY	
AGENCY ADDRESS	

© KOCOM Warranties the original purchaser of this product as follows.

- 1) This product is produced under strict quality control and inspection procedures.
- 2) If this product breaks down during proper use as a result of product defect, KOCOM will repair it within one year from date of purchase free of charge.
- 3) The following cases will be subject to charge, even during warranty period:
  - a. Breakdown during transport, or through careless treatment, by consumer.
  - b. Breakdown cause by unauthorized repair, or system modification.
  - c. Breakdown caused by natural disaster or power disorder.

**KOCOM CO.,LTD.**

<http://www.kocom.com>

KLP1000 04.07

# KOCOM

## BUS TYPE - DIGITAL MULTIPLE DOORPHONE (KLP-1000 & KDP-205)

Thank you very much for purchasing KOCOM BUS type multi-doorphone. please read this manual thoroughly to ensure correct usage, before operating



## Contents

1. Special Features ----- 1
  2. Precautions for Operation -- 1
  3. Components ----- 1
  4. DIP S/W Setting----- 2
  5. How to operate ----- 3
  6. Function ----- 5
  7. Specifications ----- 6
  8. Installation ----- 6
- Warranty  
Warranty Card

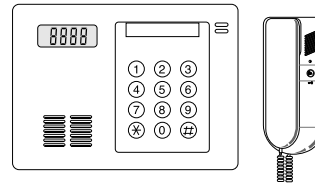

## 6. Function(KLP-1000, KDP-205)

### ■ KLP-1000

- 1 Family numbers display(four numbers)
- 2 Back tone  
3-5 seconds later after pushing family number, it sounds back tone at the speaker of KLP-1000.
- 3 Communication between KLP-1000 and KDP-205  
After call to KDP-205 at KLP-1000, you can talk over with others by KDP-205. To call to KLP-1000 at KDP-205, push the door key button in KDP-205 after picking up the handset, Then melody sound is occurred at KLP-1000 and KDP-205. After stopping melody, it begins communication between KLP-1000 and KDP-205
- 4 KLP-1000 lighting  
By lighting function of KLP-1000, it's possible to find numbers at KLP-1000.
- 5 Common gate open at outside by using password  
You can open the common gate by putting registered password.
- 6 Cancel call signal  
If you're going to cancel call signal, please push “\*” button while back tone melody sounds. In that case, back tone melody sound stops and family number would be disappeared on LED display.
- 7 Common gate open  
In case that push the door key button on KDP-205 while taking over, KLP-1000 perceive the signal and open the common gate.

### ■ KDP-205

- 1 Communication between KLP-1000 and KDP-205 If you call to KDP-205 at KLP-1000, the melody sound is occurred at KDP-205. When you pick up the handset of KDP-205, lamp is power on and stop the melody sound. And then, it begins communication between KLP-1000 and KDP-205.  
Also, you can call to KLP-1000 at KDP-205 with using door key in KDP-205
- 2 Common gate open  
In case that push the door key button on KDP-205 while taking over, KLP-1000 perceive the signal and open the common gate.

## 7. Specifications

LOBBY PHONE (KLP-1000)	Power source	ADAPTOR AC 110/220V(INPUT) DC15V(OUTPUT)			
	Power consumption	Max. :3W, Stand by :0.3W			
	Call signal sound	Melody			
	Wiring	3 Wired (Polarity), 0.8mm			
	Transmission type	Digital programming type			
	Line assignment	RED	+15V	BLUE	LINE (+)
		BLACK	GND	WHITE	Door Lock
		BLACK	LINE(-)	WHITE	Door Lock
				VIOLET	SIG
INDOOR-STATION (KDP-205)	Power source	Supplied from KLP-1000			
	Power consumption	Max. :0.2W, Stand by : 0W			
	Call signal sound	Melody			

## 8. Installation

### ■ Surface mount Type

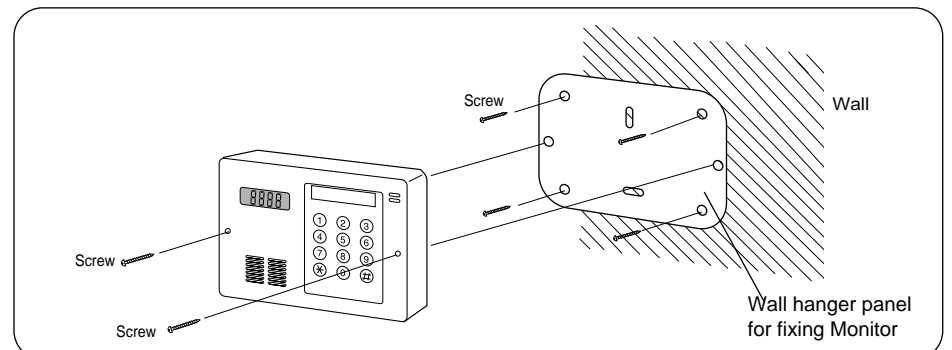

### ■ Flush mount Type

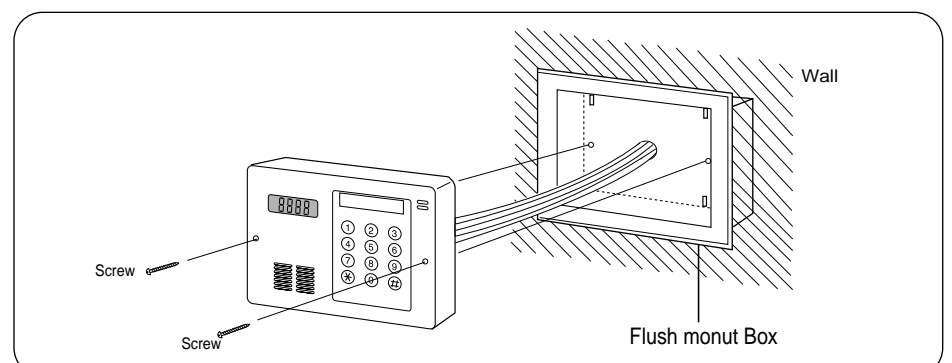

## 1. Special Features

### ■ KLP-1000

- 3 wires easy installation
- It can be distinguished in night without any extra lighting
- Up to 585 families available maximum range 39 floor ~ 15 family per floor
- Open the common gate at the outside by password
- Additional KLP-1000 can be extended in parallel

### ■ KDP-205

- Integration of communication line and door opener line
- Unnecessary extra power source

## 2. Precautions for Operation

- ⚠ Please check LINE+, LINE -, SIG line before wiring installation between KLP-1000 and KDP-205.
- In case that cancel call signal at KLP-1000, you have to push cancel button after twinkling LED.
- In case the total unit number is over 250 pcs, additional power supply is necessary to be installed.

## 3. Components

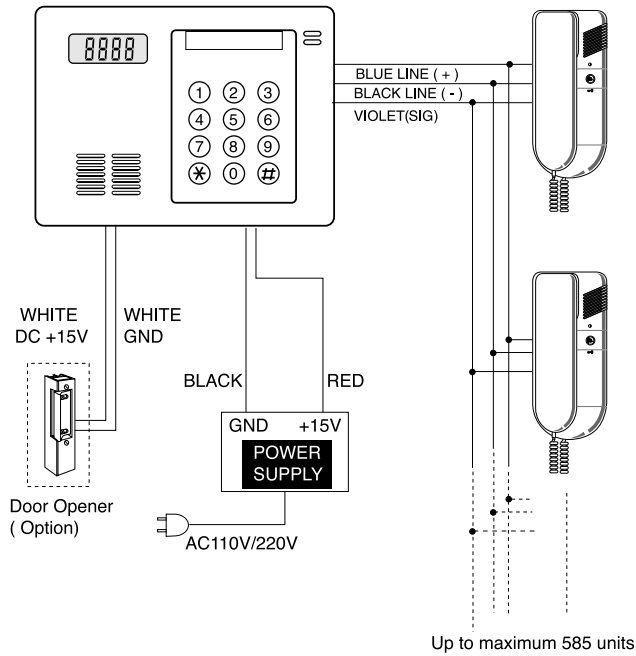

1

## 4. DIP S/W Setting

### ■ KDP-205 DIP S/W INSTRUCTION (MAX: NO.15~NO.39 FLOOR)

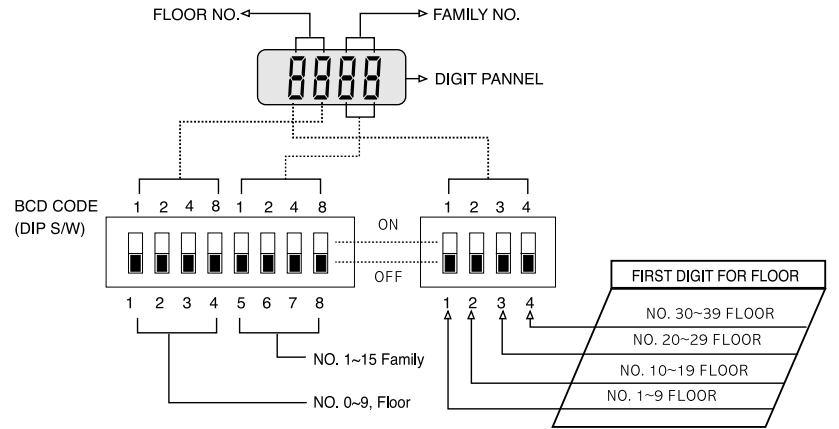

### ■ FLOOR AND FAMILY S/W INSITUTION

EX) NO.39 FLOOR & NO.1 FAMILY (DIGIT PANNEL 3901) DIP S/W SETTING INSTRUCTION

NO.3901

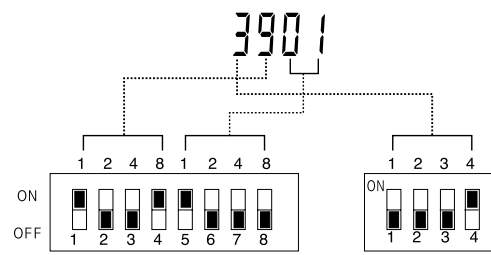

2

## 5. How to operate (Instruction for operating)

### For Visitor

#### ■ Call to each family at KLP-1000

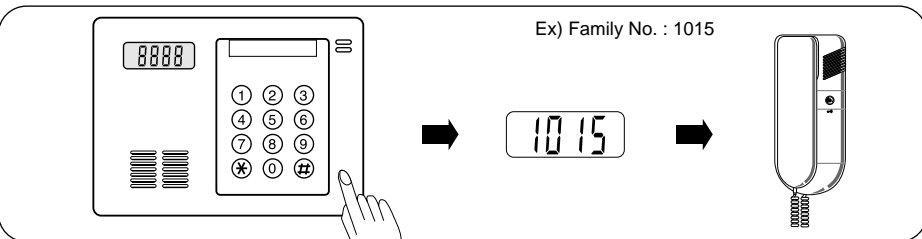

- 1 Push a family number that you want to reach at KLP-1000, and you can see it at display.
- 2 Call to KDP-205 4-5 seconds later after pushing a family number.
- 3 If you want to cancel call out, push the "\*" button. And then, you have to put into new family number after twinkling LED.

### For Householder

#### ■ Communication between KLP-1000 and KDP-205 & Door Open

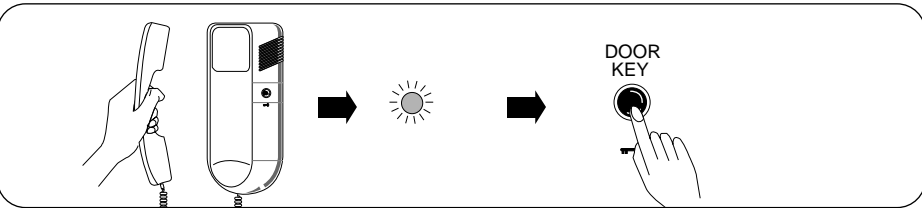

- 1 Please keep in mind polarity when install wiring.
- 2 If you call to KDP-205 at KLP-1000, the melody sound is occurred at KDP-205.
- 3 When you pick up the handset of KDP-205, lamp is power on and stop the melody sound. And then, it begins communication between KLP-1000 and KDP-205.
- 4 If you push the door key button when communicate between KLP-1000 and KDP-205, the common gate will be opened.

#### ■ Registration of password at KLP-1000

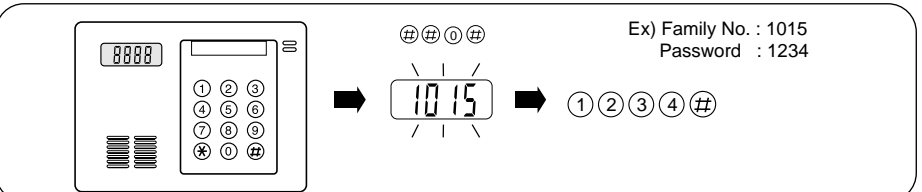

- 1 Communicate with KDP-205 at KLP-1000.
- 2 Push the "##0#", and the display of KLP-1000 is twinkled.
- 3 Push the password as four numbers after 5 seconds when display twinkle stops, and push "#" button. (Within 5 seconds)
- 4 Stop communication between KLP-1000 and KDP-205.

3

#### ■ Open the common gate at KLP-1000

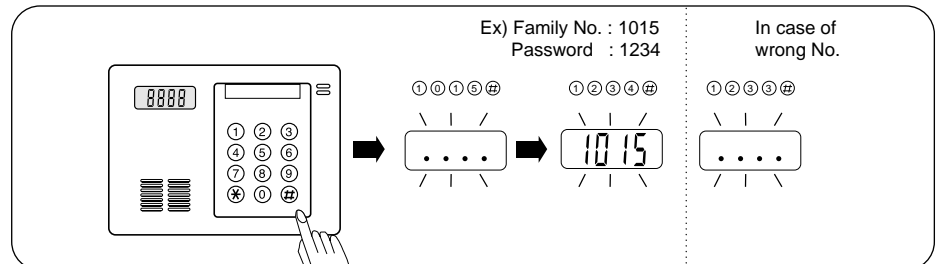

- 1 Push a family number and "#" button.
- 2 Push the password and "#" button, the common gate is opened.
- 3 In case of wrong password, the common gate is not opened, and only "..." is twinkled.

#### ■ Calling to KLP-1000 at householder

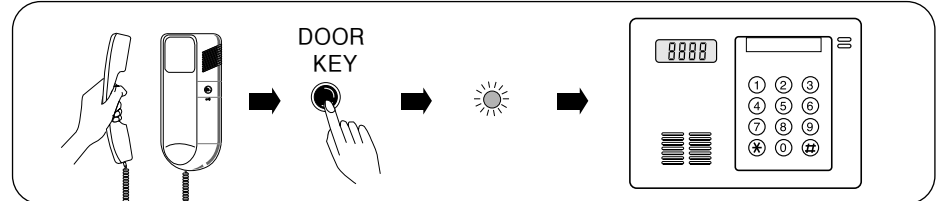

- 1 You can call to KLP-1000 at KDP-205. In first, you pick up the handset of KDP-205 and push the door key button in KDP-205.
- 2 The melody sound is simultaneously occurred at KLP-1000 and KDP-205, and the lamp in KDP-205 is power on.
- 3 After about 3-4seconds, the melody sound is stopped. And able to communicate between KLP-1000 and KDP-205 The KLP-1000 display pannel during communication.

#### ■ Door open calling to KLP-1000 at householder

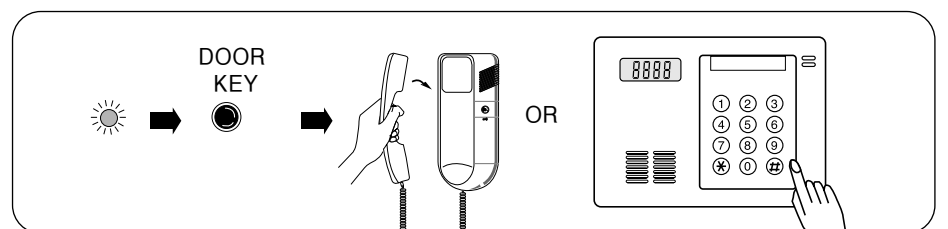

- 1 If You push Door key button when communicate with KLP-1000 at KDP-205, the common gate will be opened
- 2 If You want to stop communication between KLP-1000 and KDP-205, hang up the handset in KDP-205 or push the "\*" button in KLP-1000.
- 3 If You call to KLP-1000 again, wait for about 5seconds when stopping communication

4