

INSTALLATION/OPERATION



IRD/ERD2000 Series Receiver



C1506M-A (8/02)



CONTENTS

Section	Page
IMPORTANT SAFEGUARDS AND WARNINGS	4
DESCRIPTION	5
MODELS	5
MOUNTING	5
ERD2200 WIRING	6
IRD2024 WIRING	8
OPERATION	9
RANDOM/AUTO SCANNING	9
STANDARD COAXITRON	9
EXTENDED COAXITRON	9
AUXILIARY OPERATION	9
STANDARD COAXITRON	9
EXTENDED COAXITRON	9
FUSE REPLACEMENT	10
IRD2024	10
LENS/AUXILIARY FUSE	10
ERD2200	10
MAIN FUSE	10
ENCLOSURE FUSE	10
LENS/AUXILIARY FUSE	10
TROUBLESHOOTING	11
WIRING TABLES	12
SPECIFICATIONS	13
REGULATORY NOTICES	14
WARRANTY AND RETURN INFORMATION	15

LIST OF ILLUSTRATIONS

Figure	Page
1 Mounting Methods	5
2 ERD2200 Receiver	6
3 ERD2200 Power Connections	6
4 ERD Wiring and Switch Setting	7
5 IRD Wiring and Switch Setting	8

LIST OF TABLES

Table	Page
A 24 VAC Wiring Distances Table	12
B Video Coaxial Cable Requirements	12

IMPORTANT SAFEGUARDS AND WARNINGS

1. Read these instructions.
2. Keep these instructions.
3. Heed all warnings.
4. Follow all instructions.
5. Do not block any ventilation openings. Install in accordance with the manufacturer's instructions.
6. Do not install near any heat sources, such as radiators, heat registers, stoves, or other apparatus (including amplifiers) that produce heat.
7. Only use attachments/accessories specified by the manufacturer.
8. Use only with the cart, stand, tripod, bracket, or table specified by the manufacturer or sold with the apparatus. When a cart is used, use caution when moving the cart/apparatus combination to avoid injury from tip-over.
9. Refer all servicing to qualified service personnel. Servicing is required when the apparatus has been damaged in any way, such as power-supply cord or plug is damaged, liquid has been spilled or objects have fallen into the apparatus, the apparatus has been exposed to rain or moisture, the apparatus does not operate normally, or the apparatus has been dropped.
10. To reduce the risk of shock, do not perform any servicing other than that contained in the operating instructions unless you are qualified to do so.
11. An ALL-POLE MAINS SWITCH with a contact separation of at least 3 mm in each pole shall be incorporated in the electrical installation of the building.
12. Only use replacement parts recommended by Pelco.
13. The installation method and materials should be capable of supporting four times the weight of the apparatus.
14. Use stainless steel hardware to fasten the apparatus to outdoor surfaces.
15. For continued protection against risk of fire, replace fuses only with the same type fuses.

The following safeguards and warnings apply only to the IRD2024 model.

1. **Warning:** To reduce the risk of fire or electric shock, do not expose this apparatus to rain or moisture.
2. Do not use this apparatus near water.
3. Clean only with dry cloth.
4. Apparatus shall not be exposed to dripping or splashing, and no objects filled with liquids, such as vases, shall be placed on the apparatus.

The product and/or manual may bear the following marks:



This symbol indicates that dangerous voltage constituting a risk of electric shock is present within this unit.



This symbol indicates that there are important operating and maintenance instructions in the literature accompanying this unit.

CAUTION: RISK OF ELECTRIC SHOCK. DO NOT OPEN.
--

Please thoroughly familiarize yourself with the information in this manual prior to installation and operation.

DESCRIPTION

The IRD/ERD2000 Series Receiver operates Pelco's fixed speed pan/tilts and domes.

The receiver works with standard and extended Coaxitron® controllers, including the CM6700/7500/8500/9500, KBD9000, MPT9000/9008/9500, and MX4000. With Coaxitron control, pan/tilt and lens control signals are transmitted over the video coaxial cable. The control data is superimposed on the vertical blanking interval of the video signal.

Standard features include pan/tilt control (including auto and random scan), camera power, lens control (zoom, iris, and focus), and two auxiliary outputs. The receiver also can be used with the LRD41TLC Test Local Control module, which allows on-site testing and troubleshooting of system functions. The TLC module plugs into the receiver and operates off the receiver's power.

MODELS

IRD2024 Indoor, fixed speed, Coaxitron receiver, 24 VAC input, 24 VAC output for camera power and pan/tilt operation

ERD2200 Outdoor, fixed speed, Coaxitron receiver, 115/230 VAC input, 24 VAC output for camera power, 24, 115, or 230 VAC output for pan/tilt operation, and 115 or 230 VAC output for enclosure accessories

MOUNTING

Attach the IRD2024 to a flat surface.

Attach the ERD2200 to a vertical surface with the conduit entries facing down. Use the housing as a template for drilling mounting holes.

Use 1/4-inch fasteners (not supplied) of the appropriate length. Refer to Figure 1.

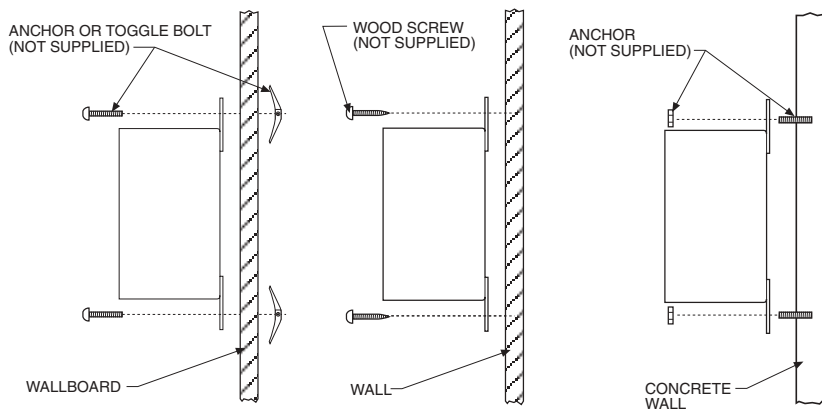

Figure 1. Mounting Methods

ERD2200 WIRING

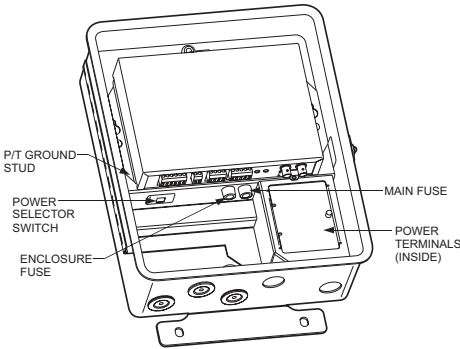

Figure 2. ERD2200 Receiver

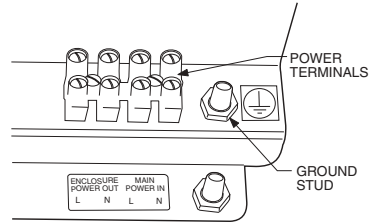

Figure 3. ERD2200 Power Connections

1. Fuses are installed for 115 VAC operation. For 230 VAC operation, install the appropriate fuses (supplied). Refer to Figure 2.
2. Set the power selector switch to either 115V or 230V to match your input power. Refer to Figure 2.
3. Loosen the thumbscrew and lift out the door protecting the power terminals (refer to Figure 2).
4. Connect main power.

Input Power	Enclosure	Main
115 VAC	4A	.5A
230 VAC	2A	.25A

The bottom of the housing has five conduit entries (fittings not supplied) to bring wiring into the receiver. Connect 115/230 VAC to the Main Power In terminals inside the receiver (refer to Figure 3) with AC high going to the L (line) terminal and AC low to the N (neutral) terminal. Connect ground wire to the stud inside the housing. Do not turn on power.

5. Connect enclosure power (optional).

If you have an enclosure with heater, blower, or defroster, connect wires from the pan/tilt or enclosure to the Enclosure Power Out terminals inside the receiver (refer to Figure 3). The enclosure must use the same power as the receiver.

Refer to Figure 4 for steps 6-12.

6. Connect the camera power.

If your camera uses 24 VAC, connect the camera to the CAM PWR connector on the front of the receiver. The camera's power must not exceed 5 VA.

If your camera uses 115 or 230 VAC, connect the camera's power leads to the Enclosure Power Out terminals inside the receiver. The camera's power must be the same as the receiver's power (Main Power In terminals).

7. Replace the door over the power terminals.

Rear View of Receiver

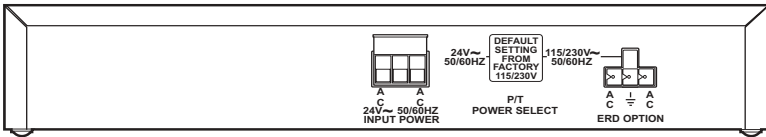

Front View of Receiver

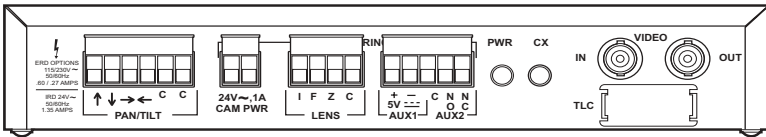

Figure 4. ERD Wiring and Switch Setting

- Set the P/T SELECT switch on the rear of the receiver according to the pan/tilt voltage requirements.



PAN/TILT VOLTAGE WARNING: The P/T POWER SELECT switch is set at the factory in the 115/230 VAC position. If your pan/tilt uses 24 VAC, remove the label over the switch and set the switch for 24 VAC. You will damage a 24 VAC pan/tilt if you operate it at 115/230 VAC.

If you select 24 VAC, the maximum output is 48 VA (supplied by the transformer inside the receiver); make sure the combined output of your pan/tilt and camera (if it also uses 24 VAC) does not exceed this output.

- Connect the pan/tilt controls (up, down, left, right, and common). Refer to Figure 2 for connection of P/T ground wire.
- Connect the motorized lens controls (iris, focus, zoom, and common).
- Connect video.

VIDEO IN comes from the camera.
VIDEO OUT goes to the controller.

If necessary, refer to Table B in the *Wiring Tables* section to determine appropriate coaxial cable types for video applications.

- Connect the auxiliary outputs (optional).

AUX 1 is a 5 VDC, 20 mA maximum, open collector output. Use the auxiliary:

- To operate low current relays
- To turn on or off a Pelco window wiper that has TTL circuitry

AUX 2 is a normally open/normally closed (Form C) relay. Relay contacts are rated at 1A maximum at 24 VDC or .5A maximum at 115 VAC.

- Double check all wiring connections, and then turn on power.

IRD2024 WIRING

Rear View of Receiver

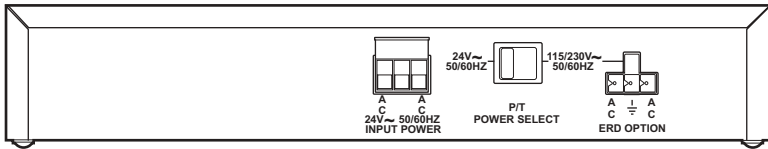

Front View of Receiver

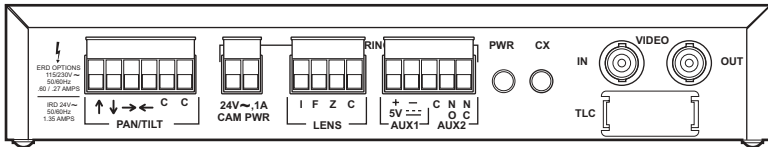

Figure 5. IRD Wiring and Switch Setting

1. Connect power to the 24 VAC INPUT connector on the rear of the receiver. The receiver's power requirement is a maximum of 5 VA, not including the camera and pan/tilt. Refer to the pan/tilt manual for its power requirements. Do not turn on power.

If necessary, refer to Table A in the *Wiring Tables* section to determine appropriate wire sizes for 24 VAC applications.

2. Make sure the P/T SELECT switch on the rear of the receiver is set toward 24 VAC. The 115/230 VAC switch position is used only with the ERD2200.
3. Connect the pan/tilt controls (up, down, left, right, and common).
4. Connect the camera power (24 VAC).
5. Connect the motorized lens controls (iris, focus, zoom, and common).
6. Connect video.

VIDEO IN comes from the camera.

VIDEO OUT goes to the controller.

If necessary, refer to Table B in the *Wiring Tables* section to determine appropriate coaxial cable types for video applications.

7. Connect the auxiliary outputs (optional).

AUX 1 is a 5 VDC, 20 mA maximum, open collector output. Use the auxiliary:

- To operate low current relays
- To turn on or off a Pelco window wiper that has TTL circuitry

AUX 2 is a normally open/normally closed (Form C) relay. Relay contacts are rated at 1A at 24 VDC or .5A at 115 VAC.

8. Double check all wiring connections, and then turn on power.

OPERATION

When power is applied to the receiver, the green PWR LED on the receiver lights. Whenever the receiver gets a valid Coaxitron control signal, the green CX LED blinks.

RANDOM/AUTO SCANNING

Operation of random and auto scanning depends on whether your transmitter/controller is communicating with the IRD2000/ERD2200 in standard or extended Coaxitron mode.

Standard Coaxitron

Press the Pan Auto (or Autoscan) key to begin random scanning. In random scan operation the pan/tilt travels between the limit stops with a random scan period of 0-60 seconds. The pan/tilt then stops for a random period of 0-60 seconds before starting another random scan period. The direction the pan/tilt moves when another scan period is started is also randomly determined. When a pan limit stop is reached, scan direction reverses automatically.

Press the Pan Auto (or Autoscan) key again to start auto scanning. After approximately a half hour of auto scanning, the pan/tilt switches to random scanning.

To turn off random/auto scanning, press the Pan Man (or Manscan) key.

Extended Coaxitron

Activate random/auto scanning by calling the following presets:

Preset 97 – Random scanning

Preset 98 – Continuous auto scanning—see WARNING below

Preset 99 – Auto scanning with half-hour timeout, after which pan/tilt switches to random scanning

Preset 96 – Stop scanning



WARNING: Activating preset 98 (continuous auto scanning) reduces the warranty on your pan/tilt to six months.

AUXILIARY OPERATION

Operation of the two auxiliaries varies depending on the transmitter/controller you are using and whether it is communicating in standard or extended Coaxitron mode. Refer to your transmitter/controller manual for the exact key-press sequence required to send an Aux 1 or Aux 2 command. The following explains how the auxiliaries respond with the different Coaxitron modes.

Standard Coaxitron

When a valid Aux 1 or Aux 2 command is received, the corresponding auxiliary operates momentarily.

Extended Coaxitron

When a valid Aux 1 or Aux 2 command is received, the corresponding auxiliary operates momentarily.

Optional Latching Mode (Extended Coaxitron Only)— When a valid Aux 3 or Aux 4 command is received, the corresponding auxiliary performs a latching operation.

NOTE: Aux 3 operates Aux 1, and Aux 4 operates Aux 2.

FUSE REPLACEMENT



CAUTION: These service instructions are for use by qualified service personnel only. To reduce the risk of electrical shock, do not perform any servicing other than that contained in the operating instructions unless you are qualified to do so.

IRD2024

Lens/Auxiliary Fuse

A 500 mA fuse protects the LENS and AUX 1 outputs. Remove the cover of the receiver to check the fuse.

ERD2200

Main Fuse

The main fuse protects the pan/tilt output when 24 VAC pan/tilt operation is selected. It also protects the 24 VAC camera output. Refer to the *ERD2200 Wiring* section for fuse location and values.

Enclosure Fuse

The enclosure fuse protects the pan/tilt output when 115/230 VAC pan/tilt operation is selected. It also protects the enclosure output. Refer to the *ERD2200 Wiring* section for fuse location and values.

Lens/Auxiliary Fuse

A 500 mA fuse protects the LENS and AUX 1 outputs. Remove the cover of the receiver inside the housing to check the fuse.

TROUBLESHOOTING

Check the wiring connections.

If the CX LED does not blink when commands are sent to the receiver, make sure the controller is working properly. Also check the video coaxial cable between the controller and the VIDEO OUT connection on the receiver.

An LRD41TLC Test Local Control Module is available from Pelco to test or troubleshoot your receiver, pan/tilt, and lens functions directly from the receiver.

This lightweight, hand-held keypad tests the up, down, left, and right functions of the pan/tilt, and the iris open/close, focus near/far, and zoom telephoto/wide functions of the lens.

1. Plug the module into the TLC connector on the front of the receiver. The module can be plugged in with the receiver's power turned on.
2. Push the buttons on the keypad to test your equipment. The TLC module can be used without disconnecting the receiver from the controller. The TLC module will override any signals from the controller.

WIRING TABLES

Table A. 24 VAC Wiring Distances Table

The following are the recommended maximum wire distances (transformer to load) for 24 VAC applications and are calculated with a 10-percent voltage drop. (Ten percent is generally the maximum allowable voltage drop for AC-powered devices.) Distances are calculated in feet; values in parentheses are meters.

		Wire Gauge					
		20	18	16	14	12	10
Total VA consumed	10	283 (86)	451 (137)	716 (218)	1,142 (348)	1,811(551)	2,880 (877)
	20	141 (42)	225 (68)	358 (109)	571 (174)	905 (275)	1,440 (438)
	30	94 (28)	150 (45)	238 (72)	380 (115)	603 (183)	960 (292)
	40	70 (21)	112 (34)	179 (54)	285 (86)	452 (137)	720 (219)
	50	56 (17)	90 (27)	143 (43)	228 (69)	362 (110)	576 (175)
	60	47 (14)	75 (22)	119 (36)	190 (57)	301 (91)	480 (146)
	70	40 (12)	64 (19)	102 (31)	163 (49)	258 (78)	411 (125)
	80	35 (10)	56 (17)	89 (27)	142 (43)	226 (68)	360 (109)
	90	31 (9)	50 (15)	79 (24)	126 (38)	201 (61)	320 (97)
	100	28 (8)	45 (13)	71 (21)	114 (34)	181 (55)	288 (87)
	110	25 (7)	41 (12)	65 (19)	103 (31)	164 (49)	261 (79)
	120	23 (7)	37 (11)	59 (17)	95 (28)	150 (45)	240 (73)
	130	21 (6)	34 (10)	55 (16)	87 (26)	139 (42)	221 (67)
	140	20 (6)	32 (9)	51 (15)	81 (24)	129 (39)	205 (62)
	150	18 (5)	30 (9)	47 (14)	76 (23)	120 (36)	192 (58)

EXAMPLE: An enclosure that requires 80 VA and is installed 35 feet (10 m) or less from the 24 VAC source would require a minimum wire gauge of 20 AWG.

Table B. Video Coaxial Cable Requirements

Cable Type*	Maximum Distance
RG59/U	750 ft (229 m)
RG6/U	1,000 ft (305 m)
RG11/U	1,500 ft (457 m)

*Minimum cable requirements:
 75 ohms impedance
 All-copper center conductor
 All-copper braided shield with 95% braid coverage

SPECIFICATIONS

ERD2200

Electrical

Input Voltage: 115/230 VAC, 50/60 Hz
Output Voltage
Camera: 24 VAC (or 115/230 VAC if using enclosure power)
Lens: 8 VDC
Pan/Tilt: 24/115/230 VAC
Enclosure: 115/230 VAC
Power Consumption
Receiver: 90 VA maximum, including 48 VA maximum at 24 VAC for pan/tilt and camera (5 VA maximum for camera)
Fuses
Main: 115 VAC – .5A 230 VAC – .25A
Enclosure: 115 VAC – 4A 230 VAC – 2A
Lens/Aux 1: .5A
Video Input/
Output: 75 ohms
Video
Bandwidth: 10 MHz
Video Gain: Unity
Video Formats: NTSC or PAL
Control
Method: Standard or extended Coaxitron
Auxiliary
Outputs: One open collector, TTL
One N.O./N.C. (Form C) relay

Mechanical

Video
Connectors: BNC
P/T, Camera, Auxiliary, Lens, Power
Connectors: Screw terminals
Cable Entry: Openings for .75-inch (1.91 cm) conduit

General

Environment: Outdoor
Construction: Aluminum (receiver), steel (housing)
Finish: Gray polyester powder coat
Operating
Temperature: -50° to 122°F (-46° to 50°C)
Dimensions: 15.2 (L) x 12.2 (W) x 5.0 (H) inches (38.6 x 31.0 x 12.7 cm)
Weight: 9.90 lb (4.50 kg)

Certifications/Ratings

CE, Class B
UL Listed
UL Listed to Canadian safety standards
NEMA 4, IP 66

IRD2024

Electrical

Input Voltage: 24 VAC, 50/60 Hz
Output Voltage
Camera: 24 VAC
Lens: 8 VDC
Power Consumption
Receiver: 45 VA maximum
Fuses
Lens/Aux 1: .5A
Video Input/
Output: 75 ohms
Video
Bandwidth: 10 MHz
Video Gain: Unity
Video Formats: NTSC or PAL
Control
Method: Standard or extended Coaxitron
Auxiliary
Outputs: One open collector, TTL
One N.O./N.C. (Form C) relay

Mechanical

Video
Connectors: BNC
P/T, Camera, Auxiliary, Lens, Power
Connectors: Screw terminals

General

Environment: Outdoor
Construction: Aluminum
Finish: Black polyester powder coat
Operating
Temperature: -10° to 122°F (-23° to 50°C)
Dimensions: 10.3 (L) x 6.0 (W) x 1.75 (H) inches (26.2 x 15.2 x 4.4 cm)
Weight: 1.25 lb (0.58 kg)

Certifications/Ratings

CE, Class B
UL Listed
UL Listed to Canadian safety standards
NEMA 1, IP 10

(Design and product specifications subject to change without notice.)

REGULATORY NOTICES

NOTE: This equipment has been tested and found to comply with the limits of a Class B digital device, pursuant to part 15 of the FCC rules. These limits are designed to provide reasonable protection against harmful interference in a residential installation. This equipment generates, uses, and can radiate radio frequency energy and, if not installed and used in accordance with the instructions, may cause harmful interference to radio communications. However there is no guarantee that the interference will not occur in a particular installation. If this equipment does cause harmful interference to radio or television reception, which can be determined by turning the equipment off and on, the user is encouraged to try and correct the interference by one or more of the following measures:

- Reorient or relocate the receiving antenna.
- Increase the separation between the equipment and the receiver.
- Connect the equipment into an outlet on a circuit different from that to which the receiver is connected.
- Consult the dealer or an experienced radio/TV technician for help.

WARRANTY AND RETURN INFORMATION

WARRANTY

Pelco will repair or replace, without charge, any merchandise proved defective in material or workmanship for a period of one year after the date of shipment. Exceptions to this warranty are as noted below:

- Five years on Pelco manufactured cameras (CC3500/CC3600/CC3700 and MC3500/MC3600 Series); two years on all other cameras.
- Three years on Genex® Series (multiplexers, server, and keyboard).
- Two years on all standard motorized or fixed focal length lenses.
- Two years on Legacy®, Camclosure® Camera Systems, CM6700/CM6800/CM8500/CM9500/CM9740/CM9760 Matrix, DF5 and DF8 Series Fixed Dome products.
- Two years on Spectra®, Esprit®, and PS20 Scanners, including when used in continuous motion applications.
- Two years on Esprit and WW5700 series window wiper (excluding wiper blades).
- Eighteen months on DX Series digital video recorders.
- One year (except video heads) on video cassette recorders (VCRs). Video heads will be covered for a period of six months.
- Six months on all pan and tilts, scanners or preset lenses used in continuous motion applications (that is, preset scan, tour and auto scan modes).

Pelco will warrant all replacement parts and repairs for 90 days from the date of Pelco shipment. All goods requiring warranty repair shall be sent freight prepaid to Pelco, Clovis, California. Repairs made necessary by reason of misuse, alteration, normal wear, or accident are not covered under this warranty.

Pelco assumes no risk and shall be subject to no liability for damages or loss resulting from the specific use or application made of the Products. Pelco's liability for any claim, whether based on breach of contract, negligence, infringement of any rights of any party or product liability, relating to the Products shall not exceed the price paid by the Dealer to Pelco for such Products. In no event will Pelco be liable for any special, incidental or consequential damages (including loss of use, loss of profit and claims of third parties) however caused, whether by the negligence of Pelco or otherwise.

The above warranty provides the Dealer with specific legal rights. The Dealer may also have additional rights, which are subject to variation from state to state.

If a warranty repair is required, the Dealer must contact Pelco at (800) 289-9100 or (559) 292-1981 to obtain a Repair Authorization number (RA), and provide the following information:

1. Model and serial number
2. Date of shipment, P.O. number, Sales Order number, or Pelco invoice number
3. Details of the defect or problem

If there is a dispute regarding the warranty of a product which does not fall under the warranty conditions stated above, please include a written explanation with the product when returned.

Method of return shipment shall be the same or equal to the method by which the item was received by Pelco.

RETURNS

In order to expedite parts returned to the factory for repair or credit, please call the factory at (800) 289-9100 or (559) 292-1981 to obtain an authorization number (CA number if returned for credit, and RA number if returned for repair).

All merchandise returned for credit may be subject to a 20% restocking and refurbishing charge.

Goods returned for repair or credit should be clearly identified with the assigned CA or RA number and freight should be prepaid. Ship to the appropriate address below.

If you are located within the continental U.S., Alaska, Hawaii or Puerto Rico:

Service Department
Pelco
3500 Pelco Way
Clovis, CA 93612-5699

If you are located outside the continental U.S., Alaska, Hawaii or Puerto Rico:

Intermediate Consignee
American Overseas Air Freight
320 Beach Road
Burlingame, CA 94010
USA

Ultimate Consignee
Pelco
3500 Pelco Way
Clovis, CA 93612-5699
USA

© Pelco, the Pelco logo, Spectra, Genex, Esprit, Camclosure, and Legacy are registered trademarks of Pelco.
© Copyright 2002, Pelco. All rights reserved.

REVISION HISTORY

Manual #	Date	Comments
C1506M	3/00	Original version.
C1506M-A	8/02	Revised manual per ECO #02-8195 to meet UL standards. Added FCC notice.



World Headquarters
3500 Pelco Way
Clovis, California 93612 USA

USA & Canada
Tel: 800/289-9100
Fax: 800/289-9150

International
Tel: 1-559/292-1981
Fax: 1-559/348-1120

www.pelco.com

ISO9001